

GN 412.2 | Positioning boss

Steel



MATERIAL

Hardened and black-oxide steel.

FEATURES AND APPLICATIONS

GN 412.2 bosses are generally used to optimise the positioning of indexing plungers.

Suitable for use on positioning flanges GN 412.1 (see page 781) and GN 612.1 (see page 781) with M12 and M16 threads.



GN 412.3 | Positioning boss

Steel



MATERIAL

Hardened and black-oxide steel.

FEATURES AND APPLICATIONS

GN 412.3 bosses are generally used to optimise the positioning of indexing plungers.

Suitable for use on positioning flanges GN 412.1 (see page 781) and GN 612.1 (see page 780) with M12 and M16 threads.



Application example

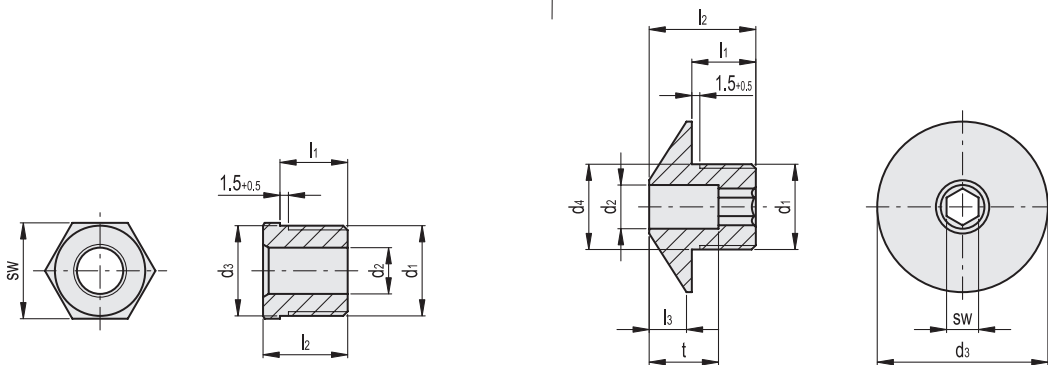
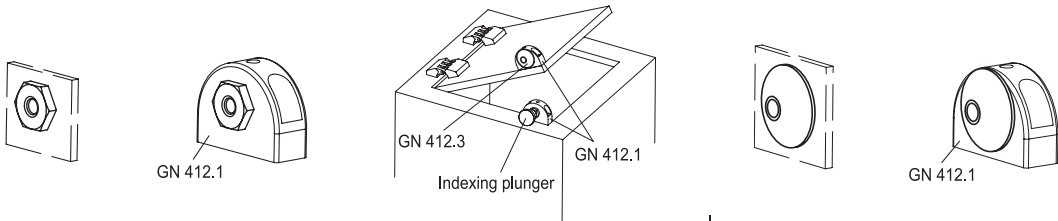

Code	Description	d1	d2 +0.1	d3 -0.05	l1 -0.2	l2	sw	Δ
GN.41251	GN 412.2-M12x1.5-B4.2	M12x1.5	4.2	12	10	13	13	10
GN.41253	GN 412.2-M12x1.5-B5.2	M12x1.5	5.2	12	10	13	13	10
GN.41255	GN 412.2-M12x1.5-B6.2	M12x1.5	6.2	12	10	13	13	10
GN.41265	GN 412.2-M16x1.5-B8.2	M16x1.5	8.2	16	12	15	17	18
GN.41261	GN 412.2-M16x1.5-B10.2	M16x1.5	10.2	16	12	15	17	18
GN.41263	GN 412.2-M16x1.5-B12.2	M16x1.5	12.2	16	12	15	17	18

Code	Description	d1	d2 +0.1	d3 -0.05	d4	l1	l2	l3	sw	t	Δ
GN.41281	GN 412.3-M12x1.5-B5.2	M12x1.5	5.2	24	12	10	16	5	4	11	17
GN.41283	GN 412.3-M12x1.5-B6.2	M12x1.5	6.2	24	12	10	16	5	4	11	16
GN.41287	GN 412.3-M16x1.5-B8.2	M16x1.5	8.2	32	16	12	20	7	6	13	28
GN.41289	GN 412.3-M16x1.5-B10.2	M16x1.5	10.2	32	16	12	20	7	6	13	26

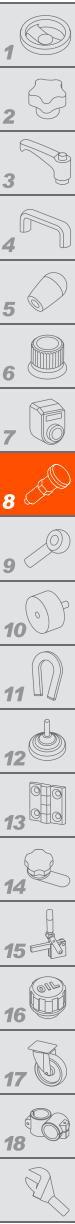

Indexing and positioning elements