

Accumulator shut off block

RE 50131/05.13
Replaces: 08.11

1/18

Type ABZSS

Nominal diameter DN08; 10; 20; 30
Component series 3X
Maximum operating pressure 350 bar [5075 psi]

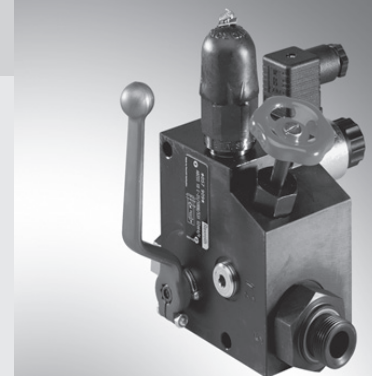

ABZSS

Table of contents

Contents	Page
Symbols, Function	2
Ordering code	3
Standard types	4, 5
Mating connectors	6
Technical data	6
Tightening torque depending on pressure relief valve and size	6
Unit dimensions, type tested pressure relief valves	7 ... 12
Accessories: Accumulator adapter, ordering code	13 ... 15
Safety instructions	16 ... 18

Information on available spare parts:
www.boschrexroth.com/spc

Symbols

DN08

Version "M" (manual unloading)

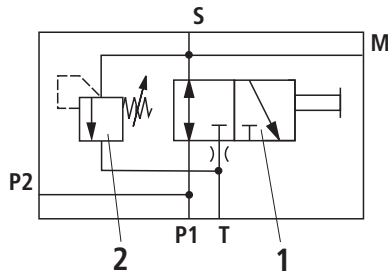

Connection designation:

M	Measuring port
P1	Pump connection
P2	Pump connection
S	Accumulator port
T	Tank port

1	System shut-off cock with manual unloading
2	Pressure relief valve

DN10, 20 and 30

Version "M" (manual unloading)

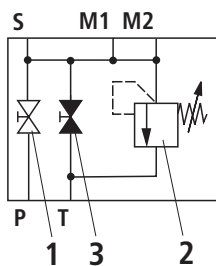

1	System shut-off cock
2	Pressure relief valve
3	Manual unloading
4	Electro-magnetic unloading, optional

Version "E" (manual and electro-magnetic unloading)

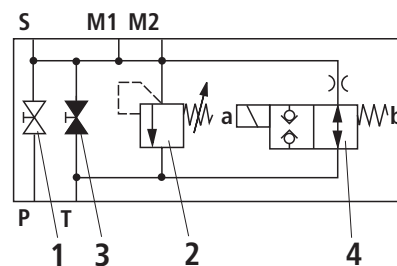

Connection designation:

M1; M2	Measuring port
P	Pump connection
S	Accumulator port
T	Tank port

Function

The accumulator shut off block is used for safety, isolating and unloading functions in hydraulic accumulators.

It meets the requirements and safety regulations according to DIN 24552 Pressure vessels regulation and technical rules pressure containers (TRB 403 and/or TRB 404).

The connection between the accumulator shut off block and the accumulator is established by means of an accumulator adapter.

By means of the pressure relief valve, the accumulator is protected from inadmissible overpressure. The **pressure relief valve must not accept any control tasks**. Care must be taken that the distance between the maximum operating pressure and the working pressure is sufficient. Responding of the pressure relief valve is to be prevented as far as possible.

Ordering code

ABZSS		-3X /		E /				*	
Accumulator shut off block = ABZSS									Further details in the plain text e.g. SO30 (see page 11)
Type of connection									Connection thread
Piping connection = no code									no code = BSP thread (ISO 228 part 1)
Subplate mounting = -P ¹⁾									12 = ²⁾ SAE thread (ANSI B1.1)
Nominal diameter									Seal material (elastomer)
DN08 = 08									V = FKM seals
DN10 = 10									W = ⁷⁾ NBR seals for water glycol HFC
DN20 = 20									Electrical connection ⁵⁾
DN30 = 30									K4 = ⁶⁾ without mating connector, with protective cap
Unloading									Voltage type ⁵⁾
Manual = M									G24 = DC voltage 24 V
Manual and electro-magnetic (without manual override) = E ²⁾									G96 = ⁸⁾ AC voltage 110 V
Component series									G205 = ⁸⁾ AC voltage 230 V
Component series 30 to 39 (30 to 39: unchanged installation and connection dimensions) = 3X									Accumulator adapter
Pressure adjustment (others upon request)									with BSP thread
50 bar [730 psi] = 50									DN08 DN10 DN20 DN30
100 bar [1450 psi] = 100									S104 = S30 = S30 = G1/2
140 bar [2030 psi] = 140									S108 = S31 = S31 = G3/4
210 bar [3050 psi] = 210									S105 = S10 = S10 = G3/4
350 bar [5075 psi] = 350 ³⁾									S107 = S12 = S12 = S307 = G1 1/4
Pressure relief valve, type tested (with CE mark) ⁴⁾ = E									S109 = S13 = S13 = S309 = G2
									with SAE thread
									DN10 DN20 DN30
									S64 = S64 = 3/4 - 16 UNF
									S60 = S60 = 11/18 - 12 UN
									S62 = S62 = S620 = 1 5/8 - 12 UN
									S63 = S63 = S630 = 1 7/8 - 12 UN
									no code = without accumulator adapter

¹⁾ Only available in DN30

²⁾ Not available with DN08

³⁾ Type SO30 delivered with pressure rating 315 bar [4570 psi]

⁴⁾ According to directive 97/23/EC (pressure equipment directive)

⁵⁾ Only with electro-magnetic unloading version "E"

⁶⁾ Mating connector must be ordered separately (see page 6)

⁷⁾ Special version

⁸⁾ For connection to the AC voltage mains, a DC solenoid **must** be used, which is controlled via a rectifier (see table on the right). In case of individual connections, a large mating connector with integrated rectifier can be used (separate order, see page 6).

Alternating voltage mains (admissible voltage tolerance ±10 %)	Nominal voltage of the DC solenoid in case of operation with alternating voltage	Ordering code
110 V - 50/60 Hz 120 V - 60 Hz	96 V	G96
230 V - 50/60 Hz	205 V	G205

Standard types

Accumulator type	Accumulator size in l [gal]	Set pressure of the pressure relief valve in bar [psi]	Accumulator shut off block DN	Denomination	Material no.		
Diaphragm type accumulator RE50150	0.5 [0.13]	160 [2320]	08	ABZSS 08 M-3X/160E/S104V	R901263004		
			10	ABZSS 10 M-3X/160E/S30V	R900711145		
	0.7 [0.18]	180 [2610]	08	ABZSS 08 M-3X/180E/S104V	R901263013		
			10	ABZSS 10 M-3X/180E/S30V	R904100876		
		250 [3625]	08	ABZSS 08 M-3X/250E/S104V	R901263011		
			10	ABZSS 10 M-3X/250E/S30V	R901147802		
	1.0 [0.26]	200 [2900]	08	ABZSS 08 M-3X/200E/S104V	R901263012		
			10	ABZSS 10 M-3X/200E/S30V	R904100849		
	1.4 [0.37]	140 [2030]	08	ABZSS 08 M-3X/140E/S104V	R901263020		
			10	ABZSS 10 M-3X/140E/S30V	R900711138		
		250 [3625]	08	ABZSS 08 M-3X/250E/S104V	R901263011		
			10	ABZSS 10 M-3X/250E/S30V	R901147802		
	2.0 [0.53]	100 [1450]	08	ABZSS 08 M-3X/100E/S108V	R901263014		
			10	ABZSS 10 M-3X/100E/S31V	R900711131		
		250 [3625]	08	ABZSS 08 M-3X/250E/S108V	R901263015		
			10	ABZSS 10 M-3X/250E/S31V	R901147799		
	2.8 [0.74]	70 [1015]	08	ABZSS 08 M-3X/070E/S108V	R901263016		
			10	ABZSS 10 M-3X/070E/S31V	R901259516		
		250 [3625]	08	ABZSS 08 M-3X/250E/S108V	R901263015		
			10	ABZSS 10 M-3X/250E/S31V	R901147799		
3.5 [0.91]	250 [3625]	08	ABZSS 08 M-3X/250E/S108V	R901263015			
		10	ABZSS 10 M-3X/250E/S31V	R901147799			
Bladder-type accumulator RE50170	1.0 [0.26]	350 [5075]	08	ABZSS 08 M-3X/350E/S105V	R901263022		
			10	ABZSS 10 M-3X/350E/S10V	R901259519		
	2.5 [0.66]		08	ABZSS 08 M-3X/350E/S107V	R901272573		
			10	ABZSS 10 M-3X/350E/S12V	R901272576		
	4.0 [1.06]		08	ABZSS 08 M-3X/350E/S107V	R901272573		
			10	ABZSS 10 M-3X/350E/S12V	R901272576		
	6.0 [1.56]		08	ABZSS 08 M-3X/350E/S107V	R901272573		
			10	ABZSS 10 M-3X/350E/S12V	R901272576		
	10 [2.64]		330 [4785]	20	ABZSS 20 M-3X/330E/S13V		R900711415
	20 [5.28]				30	ABZSS 30 M-3X/330E/S 309V	
	32 [8.45]			ABZSS-P 30 M-3X/330E/S309V		R901146459	
				50 [13.2]		ABZSS 30 M-3X/330E/S 309V	
ABZSS-P 30 M-3X/330E/S309V		R901146459					

More standard types and units are contained in the EPS (standard price list).

For more standard types see page 5.

Standard types (continued)

Accumulator type	Accumulator size in l [gal]	Set pressure of the pressure relief valve in bar [psi]	Accumulator shut off block DN	Denomination	Material no.
	0.5 [0.13]	160 [2320]	10	ABZSS 10 E-3X/160E/S30G 24K4V	R901263026
	0.7 [0.18]	180 [2610]	10	ABZSS 10 E-3X/180E/S30G 24K4V	R901263028
		250 [3625]	10	ABZSS 10 E-3X/250E/S30G 24K4V	R901147797
	1.0 [0.26]	200 [2900]	10	ABZSS 10 E-3X/200E/S30G 24K4V	R900709591
	1.4 [0.37]	140 [2020]	10	ABZSS 10 E-3X/140E/S30G 24K4V	R900709589
		250 [3625]	10	ABZSS 10 E-3X/250E/S30G 24K4V	R901147797
	2.0 [0.53]	100 [1450]	10	ABZSS 10 E-3X/100E/S31G 24K4V	R900709586
		250 [3625]	10	ABZSS 10 E-3X/250E/S31G 24K4V	R900709604
	2.8 [0.74]	70 [1015]	10	ABZSS 10 E-3X/070E/S31G 24K4V	R901263029
		250 [3625]	10	ABZSS 10 E-3X/250E/S31G 24K4V	R900709604
	3.5 [0.91]		10	ABZSS 10 E-3X/250E/S31G 24K4V	R900709604
	1.0 [0.26]	350 [5075]	10	ABZSS 10 E-3X/350E/S10G 24K4V	R901263027
	2.5 [0.66]		10	ABZSS 10 E-3X/350E/S12G 24K4V	R901272591
	4.0 [1.06]		10	ABZSS 10 E-3X/350E/S12G 24K4V	R901272591
	6.0 [1.56]		10	ABZSS 10 E-3X/350E/S12G 24K4V	R901272591
	10 [2.64]	330 [4785]	20	ABZSS 20 E-3X/330E/S13G 24K4V	R900709636
	20 [5.28]			30	ABZSS 30 E-3X/330E/S 309G 24K4V
	32 [8.45]		ABZSS-P 30 E-3X/330E/S 309G 24K4V		R901147879
			50 [13.2]		ABZSS 30 E-3X/330E/S 309G 24K4V
					ABZSS-P 30 E-3X/330E/S 309G 24K4V

More standard types and units are contained in the EPS (standard price list).

Mating connectors according to DIN EN 175301-803

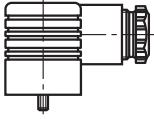
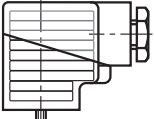
Details and more mating connectors see data sheet 08006					
Valve side	Color	Material no.			
		without circuitry	with indicator light 12 to 240 V	with rectifier 12 to 240 V	with indicator light and Z diode suppression circuit 24 V
a	Grey	R901017010	–	–	–
b	Black	R901017011	–	–	–
a/b	Black	–	R901017022	R901017025	R901017026

Technical data (For applications outside these parameters, please consult us!)

Seal material	FKM seals and/or NBR seals ¹⁾							
Operating temperature range	°C [<i>°F</i>]	–15 to +80 [<i>+5 to +176</i>]						
Maximum operating pressure	bar [<i>psi</i>]	350 [<i>5075</i>]						
Hydraulic fluid	Mineral oil (HL, HLP) according to DIN 51524 ³⁾ Triglycerides (rape seed oil) HETG according to VDMA 24568 ³⁾ Synthetic esters HEES according to VDMA 24568 ²⁾ Polyglycols HEPG according to VDMA 24568 ²⁾							
Maximum permitted degree of contamination of the hydraulic fluid - cleanliness class according to ISO 4406 (C)	Class 20/18/15 ⁴⁾							
Block material	Steel							
Direct operated pressure relief valve	Type	DBDS...K1X/...VB or DBDS...K1X/...E ¹⁾ according to data sheet 25402						
Cartridge seat valve	Type	KSDER1PB/HN9V according to data sheet 18136-20						
Protection class according to VDE 0470-1 (DIN EN 60529), DIN 40050-9	– Version "K4"	IP 65 with mating connector mounted and locked						
Nominal diameter	DN	08	10	20	30	30S030	P30...	
Weight	– Version "M"	kg [<i>lbs</i>]	4.0 [8.8]	5.2 [11.5]	8.5 [18.7]	20.5 [45.2]	26.5 [58.4]	33.1 [72.8]
	– Version "E"	kg [<i>lbs</i>]	–	5.5 [12.1]	8.8 [19.4]	20.8 [45.8]	26.8 [59.1]	33.4 [73.5]

¹⁾ Special version

²⁾ Suitable for FKM seals

³⁾ Suitable for FKM and NBR seals

⁴⁾ The cleanliness classes specified for the components must be adhered to in hydraulic systems. Effective filtration pre-

vents faults and at the same time increases the service life of the components.

For selecting the filters, see data sheets 50070, 50076, 50081, 51421, 51422, 51418, 51419, 51424, 51425 and 51448.

Tightening torque depending on pressure relief valve and size

Pressure rating	Valve type and size ¹⁾			
	Part marking			
	DBD6 849	DBD10 850, 390	DBD20 361	DBD30 362
up to 210 bar	50 ± 5 Nm	100 ± 5 Nm	150 ± 10 Nm	350 ± 20 Nm
up to 350 bar	80 ± 5 Nm	150 ± 5 Nm	300 ± 10 Nm	500 ± 20 Nm

¹⁾ Oiled screws, tightening using a torque-controlled tool of accuracy class ±10 %

Unit dimensions: Type ABZSS 08... (DN08, dimensions in mm [inch])

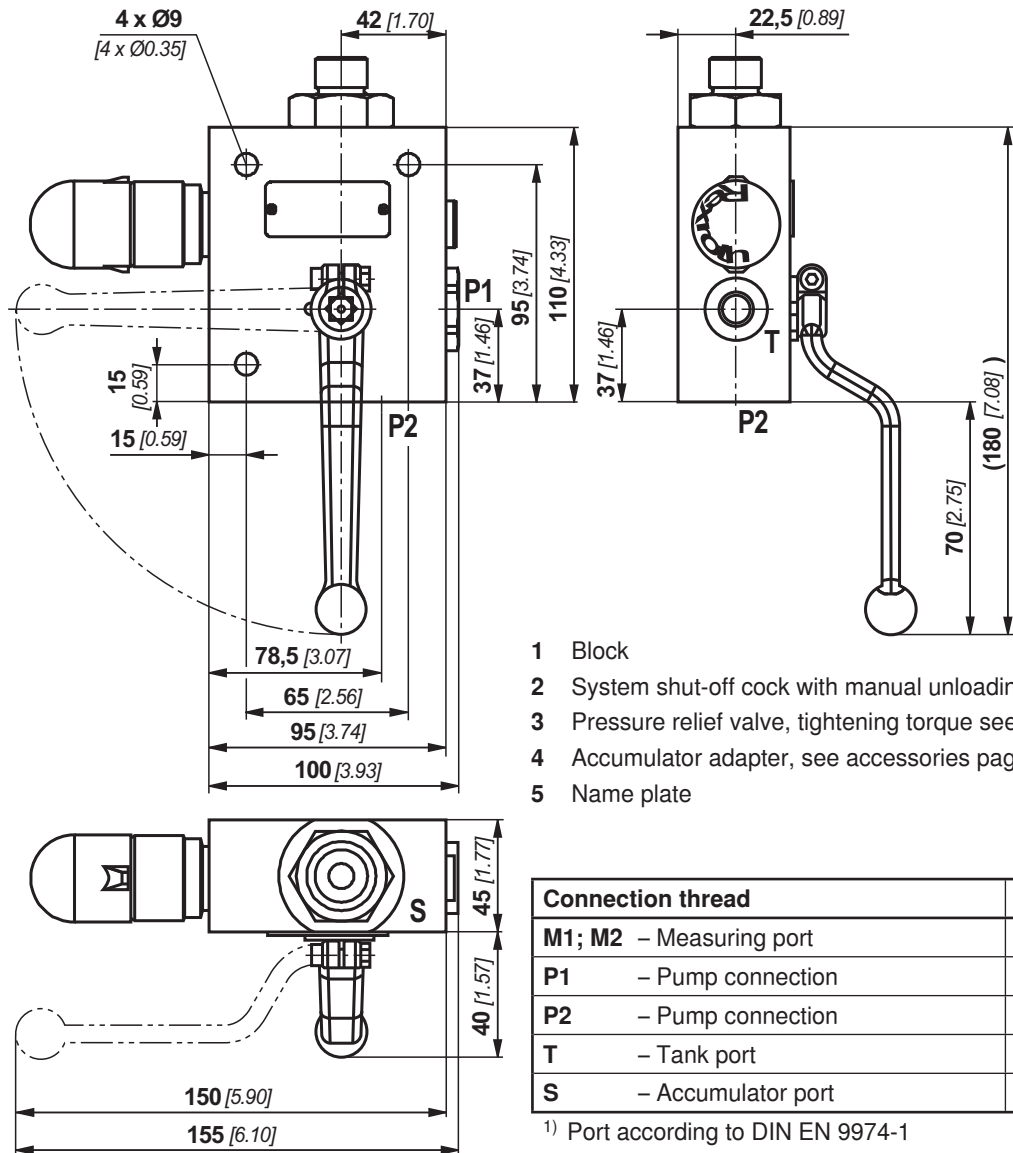

- 1 Block
- 2 System shut-off cock with manual unloading
- 3 Pressure relief valve, tightening torque see page 6
- 4 Accumulator adapter, see accessories page 13 to 15
- 5 Name plate

Connection thread	BSP
M1; M2 – Measuring port	G1/4
P1 – Pump connection	G3/8
P2 – Pump connection	G1/2
T – Tank port	G1/4
S – Accumulator port	M20 x 1.5 ¹⁾

¹⁾ Port according to DIN EN 9974-1

**Type tested pressure relief valve
Type DBD .../...E, size 6 – Directive 97/23/EC (pressure equipment directive)**

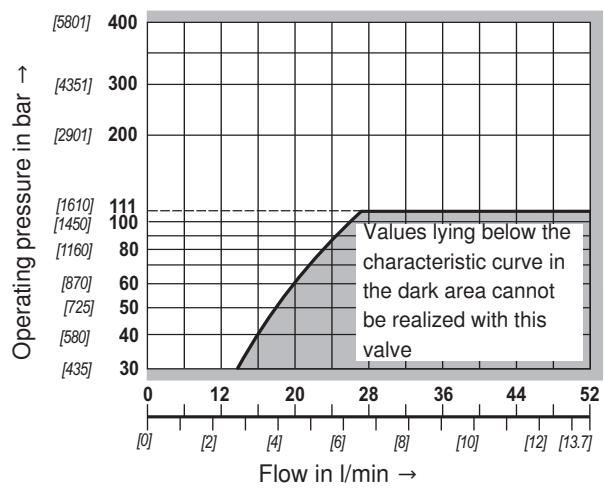

Unit dimensions: Type ABZSS 10... (DN10, dimensions in mm [inch])

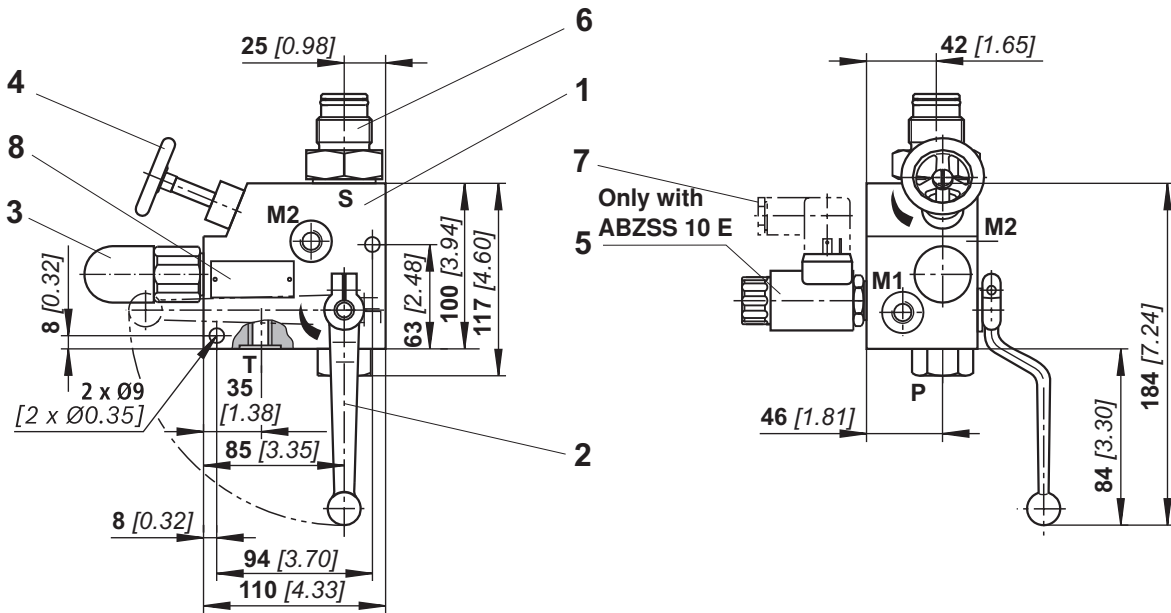

- 1 Block
- 2 System shut-off cock
- 3 Pressure relief valve, tightening torque see page 6
- 4 Manual unloading
- 5 Electro-magnetic unloading, optional
- 6 Accumulator adapter, see accessories page 13 to 15
- 7 Mating connector, separate order, see page 6
- 8 Name plate

Connection thread	BSP	SAE
M1; M2 – Measuring port	G1/4	7/16 – 20 UNF
P – Pump connection	G1/2	3/4 – 16 UNF
T – Tank port	G3/8	9/16 – 18 UNF
S – Accumulator port	M33 x 2	M33 x 2

Type tested pressure relief valve
Type DBD .../...E, size 6 – Directive 97/23/EC (pressure equipment directive)

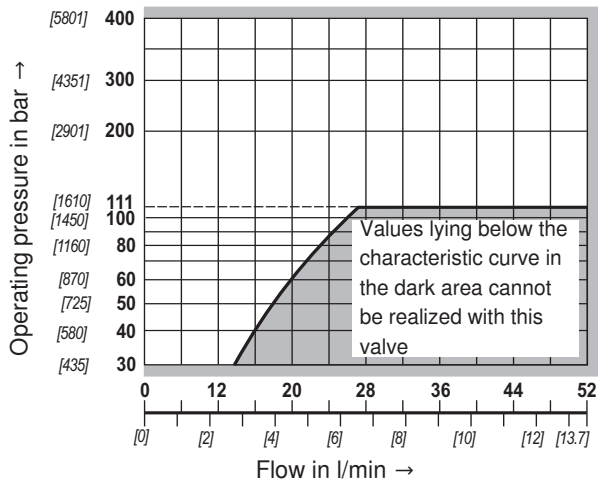

Unit dimensions: Type ABZSS 20... (DN20, dimensions in mm [inch])

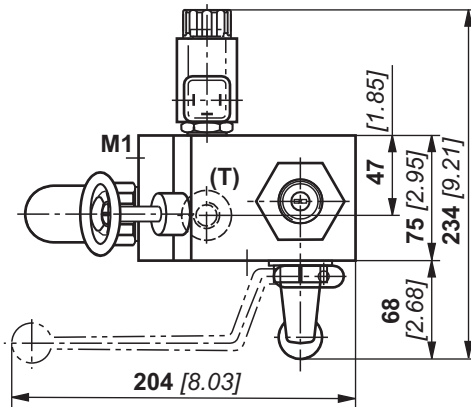
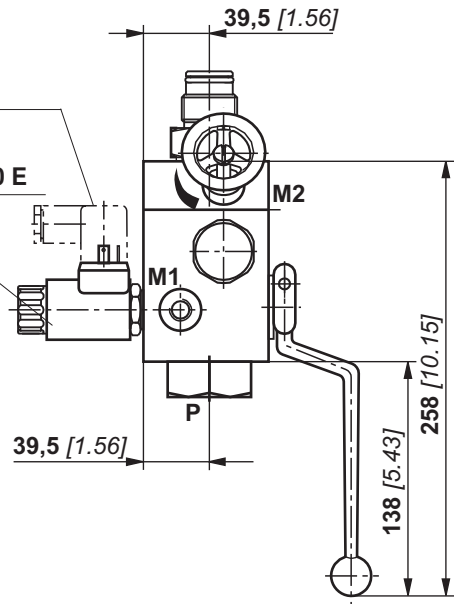
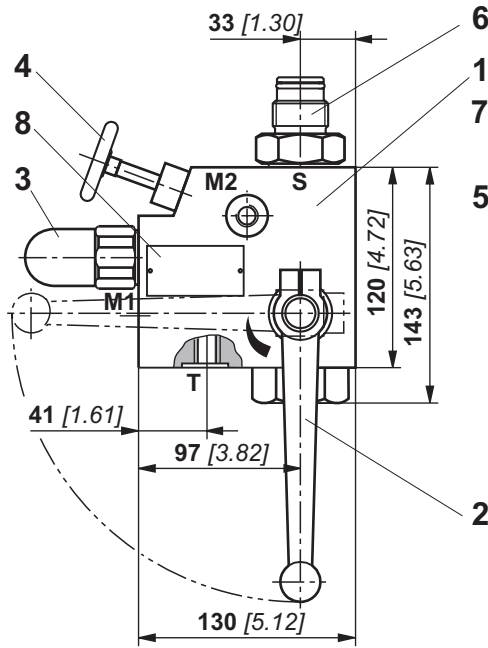

- 1 Block
- 2 System shut-off cock
- 3 Pressure relief valve, tightening torque see page 6
- 4 Manual unloading
- 5 Electro-magnetic unloading, optional
- 6 Accumulator adapter, see accessories page 13 to 15
- 7 Mating connector, separate order, see page 6
- 8 Name plate

Connection thread	BSP	SAE
M1; M2 – Measuring port	G1/4	7/16 – 20 UNF
P – Pump connection	G1	1 5/16 – 12 UN
T – Tank port	G1/2	3/4 – 16 UNF
S – Accumulator port	M33 x 2	M33 x 2

Type tested pressure relief valve

Type DBD .../...E, size 10 – Directive 97/23/EC (pressure equipment directive)

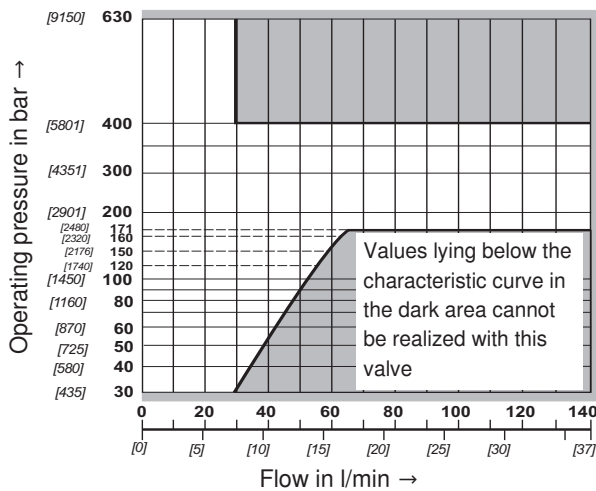

Unit dimensions: Type ABZSS 30... (DN30, dimensions in mm [inch])

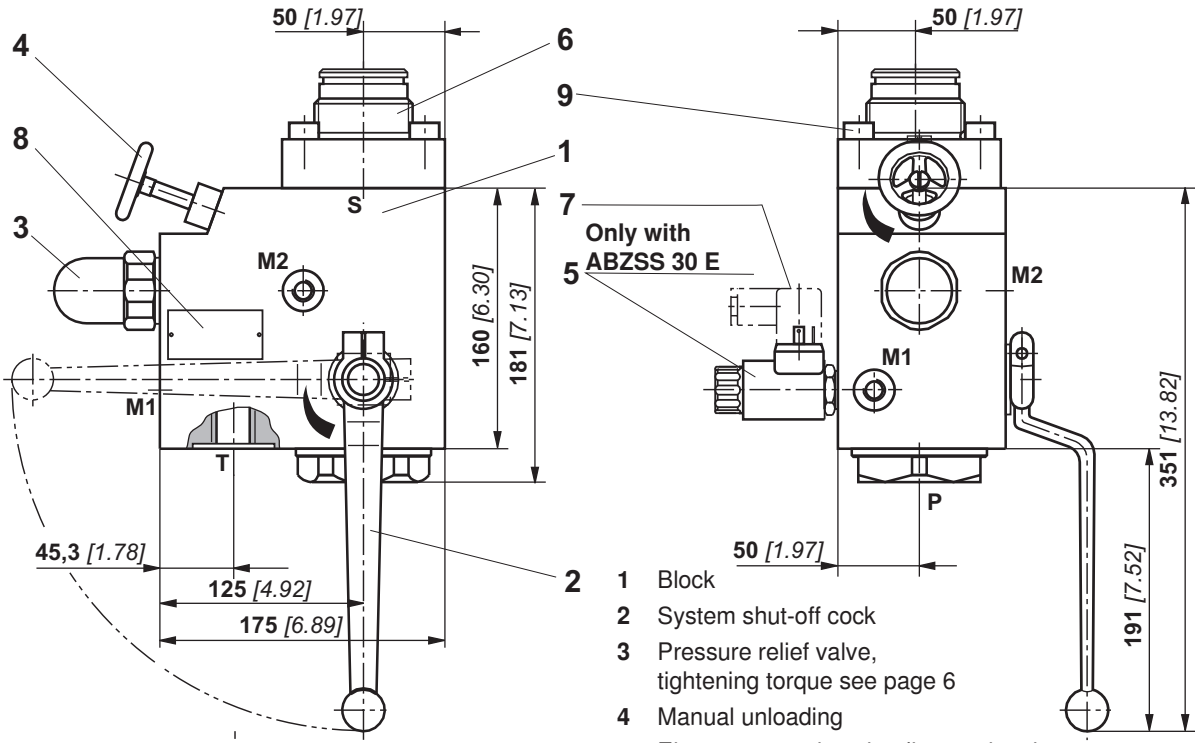

- 1 Block
- 2 System shut-off cock
- 3 Pressure relief valve, tightening torque see page 6
- 4 Manual unloading
- 5 Electro-magnetic unloading, optional
- 6 Accumulator adapter, see accessories page 13 to 15
- 7 Mating connector, separate order, see page 6
- 8 Name plate
- 9 Hexagon socket head cap screws
4 x ISO 4762-M16 x 45 - 10.9
tightening torque $M_A = 250^{+10}$ Nm [184.0^{7.4} ft-lbs]

Connection thread	BSP	SAE
M1; M2 – Measuring port	G1/4	7/16 – 20 UNF
P – Pump connection	G1 1/2	1 7/8 – 12 UN
T – Tank port	G1	1 5/16 – 12 UN
S – Accumulator port (flange)	Page 13	Page 15

Type tested pressure relief valve
Type DBD .../...E, size 20 – Directive 97/23/EC (pressure equipment directive)

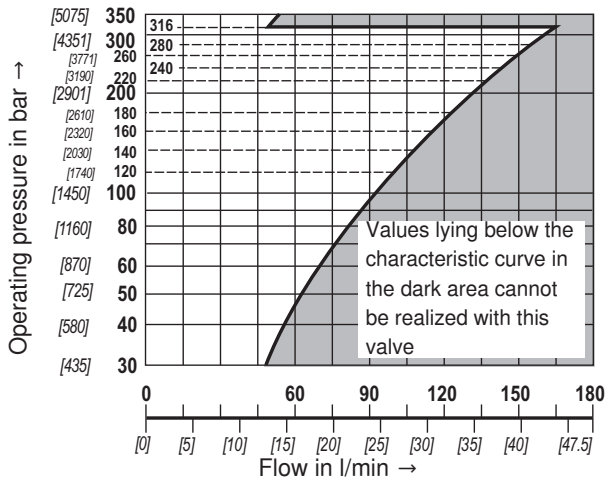

Unit dimensions: Type ABZSS 30...SO30 (DN30, dimensions in mm [inch])

As compared to the standard accumulator shut off block ABZSS 30..., the accumulator shut off block ABZSS 30...SO30 is equipped with a direct operated pressure relief valve of size 30.

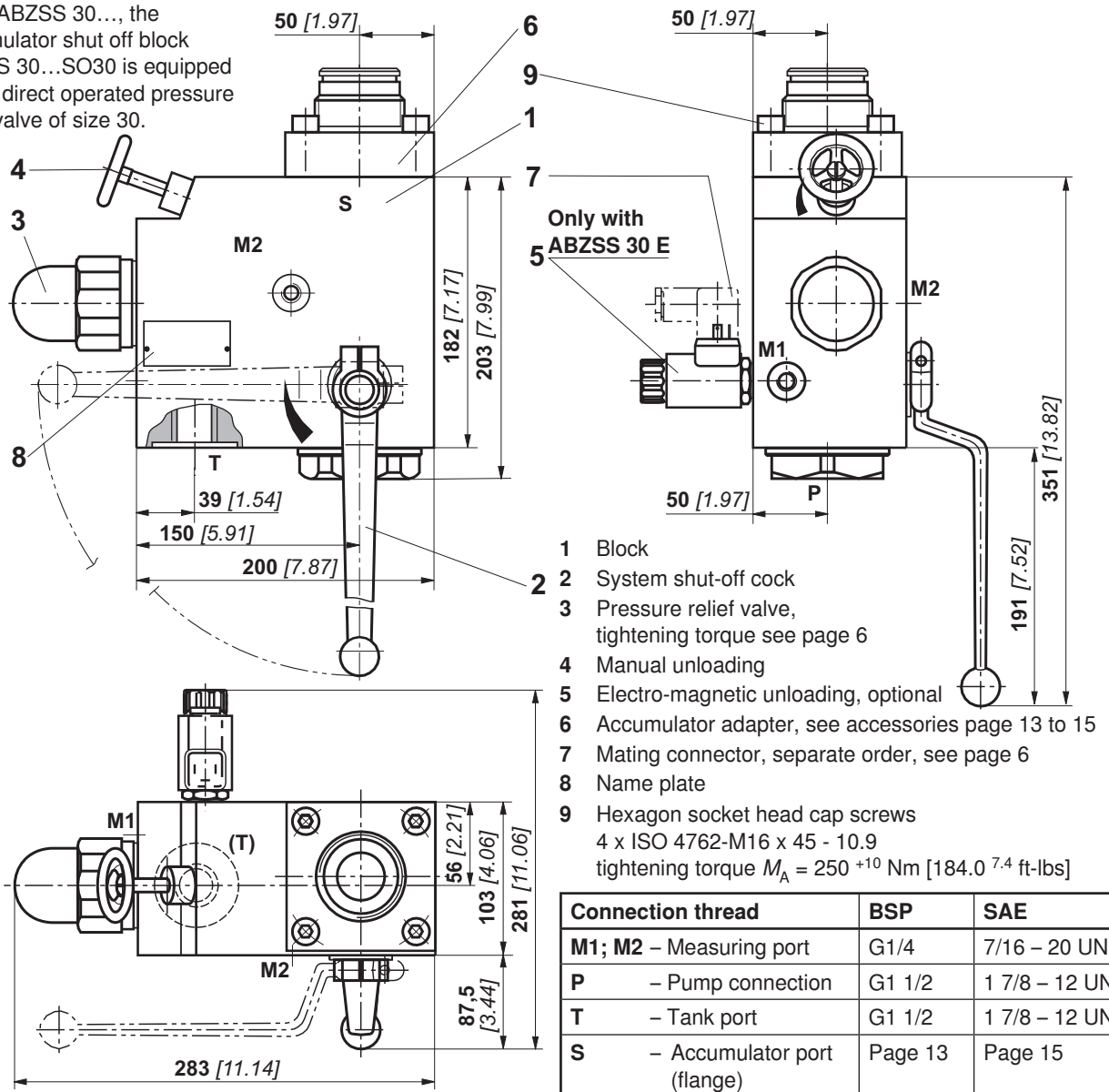

Type tested pressure relief valve

Type DBD .../...E, size 30 – Directive 97/23/EC (pressure equipment directive)

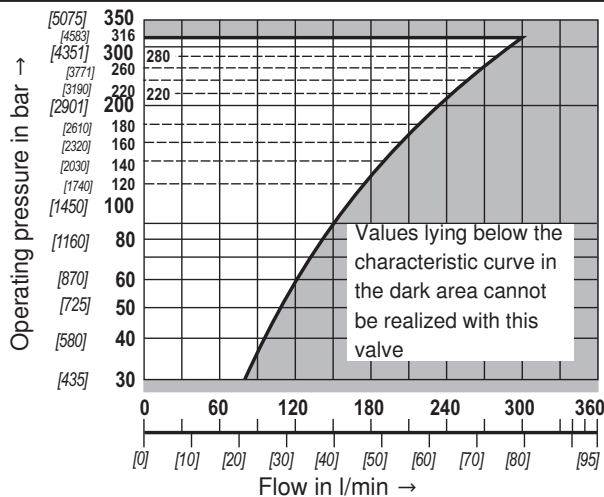

Unit dimensions: Type ABZSS-P30 (DN30, dimensions in mm [inch])

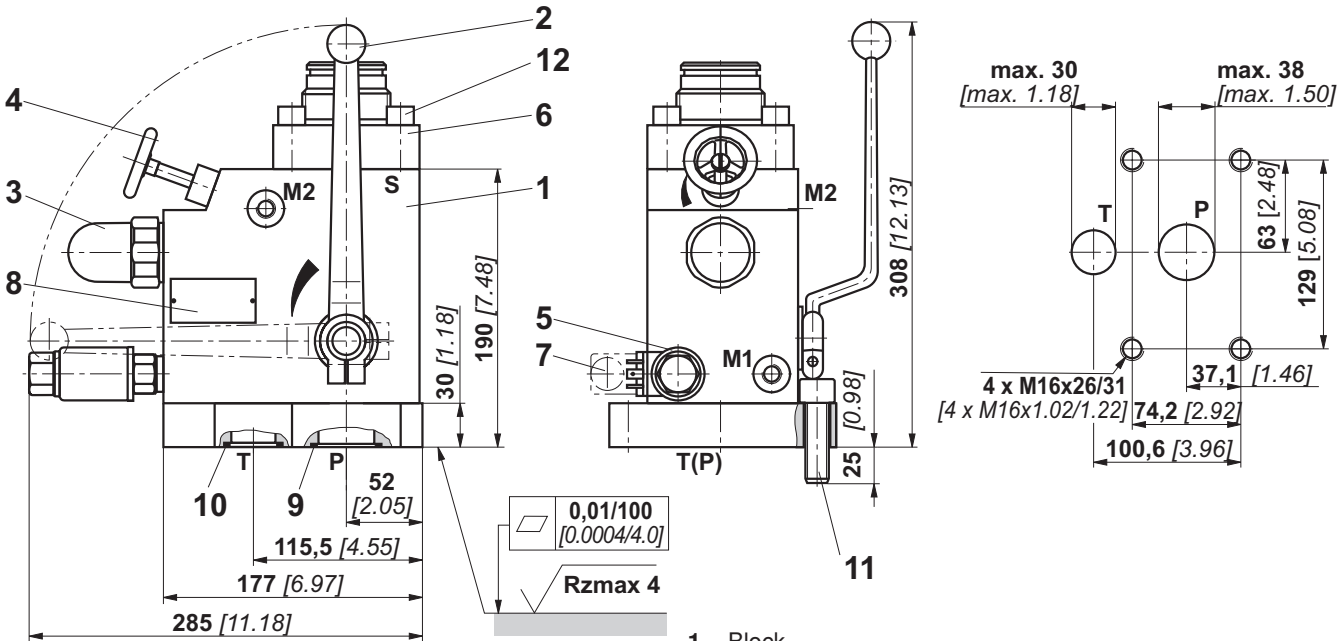

- 1 Block
- 2 System shut-off cock
- 3 Pressure relief valve, tightening torque see page 6
- 4 Manual unloading
- 5 Electro-magnetic unloading, optional
- 6 Accumulator adapter, see accessories page 13 to 15
- 7 Mating connector, separate order, see page 6
- 8 Name plate
- 9 R ring 42.50 x 3.00 x 3.00 Shore 90
- 10 R ring 34.52 x 3.53 x 3.53 Shore 90
- 11 Hexagon socket head cap screws
4 x ISO 4762-M16x55-10.9
tightening torque $M_A = 250^{+10}$ Nm [184.0^{7.4} ft-lbs]
- 12 Hexagon socket head cap screws
4 x ISO 4762-M16 x 45-10.9
tightening torque $M_A = 250^{+10}$ Nm [184.0^{7.4} ft-lbs]

Connection thread	BSP	SAE
M1; M2 – Measuring port	G1/4	7/18 – 20 UNF
S – Accumulator port (flange)	Page 13	Page 15

Type tested pressure relief valve

Type DBD .../...E, size 20 – Directive 97/23/EC (pressure equipment directive)

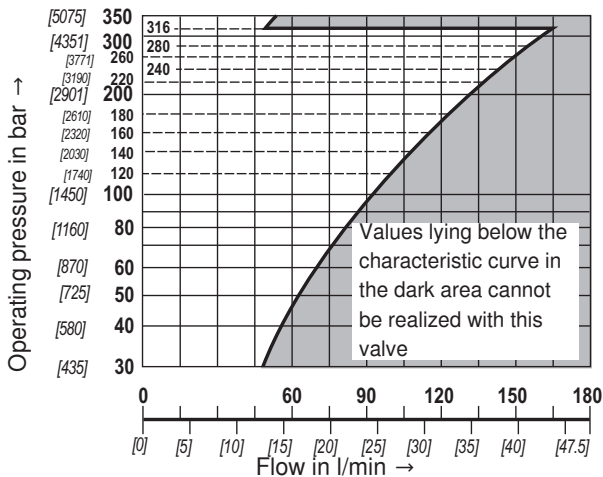

Accessories: Accumulator adapter, max. Operating pressure 350 bar [5075 psi], BSP thread (dimensions in mm [inch])

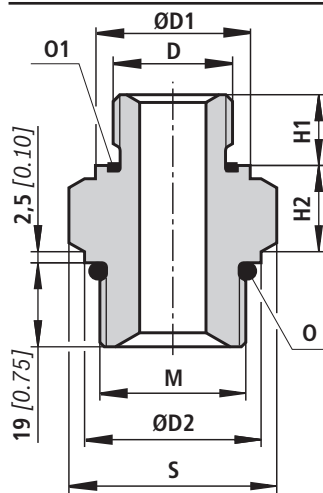

Fig. 1

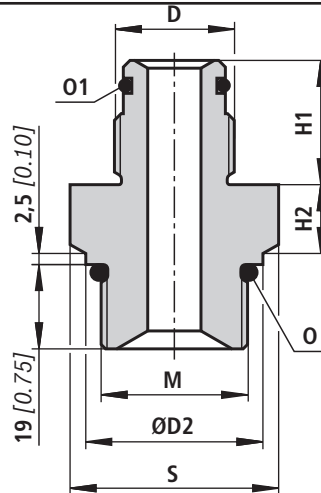

Fig. 2

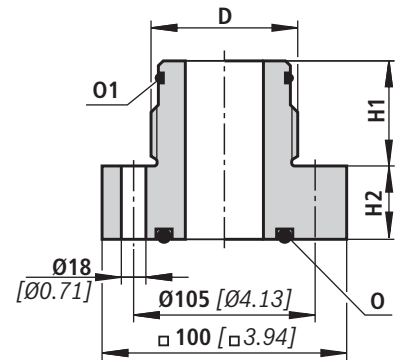

Fig. 3

Accumulator shut off block	Accumulator type	Accumulator DN	Accumulator adapter	Fig.	D	ØD1	ØD2	H1	H2	M	O	O1	S			
ABZSS 08 ABZSS 10 ABZSS 20	Diaphragm type accumulator RE 50150	0.075	S30 ¹⁾ S104 ²⁾	1	G1/2A	26.9 [1.06]		14 [0.55]	19.5 [0.76] ¹⁾ 17.5 [0.68] ²⁾			Profile seal ring G1/2A according to DIN 3869	S30 ¹⁾ , S31 ¹⁾ , S108 ²⁾ , SW41 [1.61A/F], S104 ²⁾ SW36 [1.41A/F]			
		0.16						19.5 [0.76] ¹⁾ 18 [0.70] ²⁾								
		0.32														
		0.5														
		0.7														
	1.0															
	1.4															
	Bladder-type accumulator RE 50170	2.0	S10 ¹⁾ S105 ²⁾	2	G3/4A	-	39.9 [1.57] ¹⁾ 35.0 [1.37] ²⁾	28 [1.10]	16 [0.63]	15.5 [0.61]	33x2 ¹⁾ ; 20x1.5 ²⁾	29.7x2.8 ¹⁾ ; 24x2.0 ²⁾	Profile seal ring G3/4A ac- cording to DIN 3869	S30 ¹⁾ , S31 ¹⁾ , S108 ²⁾ , SW41 [1.61A/F], S104 ²⁾ SW36 [1.41A/F]		
		2.8														
		3.5														
2.5		S12 ¹⁾ S107 ²⁾							G1 1/4A	-			37 [1.46]	16.5 [0.65] ¹⁾ 17.5 [0.68] ²⁾	30x3 [1.18x0.12]	SW46 [1.81A/F]
4.0																
6.0																
ABZSS 30 ABZSS-P30	Bladder-type accumulator RE 50170	10.0	S13 ¹⁾ S109 ²⁾	3	G2A	-	43 [1.69]	43 [1.69]	20.5 [0.81] ¹⁾ 18.5 [0.73] ²⁾	-	56.52 x 5.33	48x3 [1.89x0.12]	SW65 [2.55A/F]			
		20.0														
		35.0														
		50.0														
		2.5						S307	G1 1/4A			-	37 [1.46]	30 [1.18]	30x3 [1.18x0.12]	-
4.0																
6.0																
ABZSS 30 ABZSS-P30	Bladder-type accumulator RE 50170	10.0	S309	3	G2A	-	43 [1.69]	43 [1.69]	30 [1.18]	-	56.52 x 5.33	48x3 [1.89x0.12]	-			
		20.0														
		35.0														
		50.0														
		2.5						S307	G1 1/4A			-	37 [1.46]	30 [1.18]	30x3 [1.18x0.12]	-
4.0																
6.0																

¹⁾ Only applies to ABZSS10 and ABZSS20

²⁾ Only applies to ABZSS08

Ordering code

Short designation	ACCUMULATOR ADAPTER (SPEICHERADAPTER)	Material no. FKM	ACCUMULATOR ADAPTER (SPEICHERADAPTER)	Material no. NBR ²⁾
S10	S10V/G3/4-M33X2 *BG	R900545254	S10M/G3/4-M33X2 *BG	R900862699
S12	S12V/G1 1/4-M33X2 *BG	R900545255	S12M/G1 1/4-M33X2 *BG	R900862700
S13	S13V/G2-M33X2 *BG	R900545256	S13M/G2-M33X2 *BG	R900862701
S30	S30V/G1/2-M33X2 *BG	R900545252	S30M/G1/2-M33X2 *BG	R900862695
S31	S31V/G3/4-M33X2 *BG	R900545253	S31M/G3/4-M33X2 *BG	R900862697
S104	S104V/G1/2-M20X1.5* &	R901265402	S104M/G1/2-M20X1.5* &	R901265401
S105	S105V/G3/4-M20X1.5* &	R901265411	S105M/G3/4-M20X1.5* &	R901265407
S107	S107V/G11/4-M20X1.5*&	R901265412	S107M/G11/4-M20X1.5*&	R901265422
S108	S108V/G3/4-M20X1.5* &	R901265434	S108M/G3/4-M20X1.5* &	R901265425
S109	S109V/G2-M20X1.5* &	R901265408	S109M/G2-M20X1.5* &	R901265404
S307 ¹⁾	S307V/G 11/4-DN32 *BG	R900085303	S307M/G 11/4-DN32 *BG	R900067050
S309 ¹⁾	S309V/G2-DN32 *BG	R900545858	S309M/G2-DN32 *BG	R900862702

¹⁾ Scope of delivery contains 4 hexagon socket head cap screws ISO 4762-M16 x 45 - 10.9

²⁾ Special version

Accessories: Accumulator adapter, max. Operating pressure 350 bar [5075 psi], SAE thread (dimensions in mm [inch])

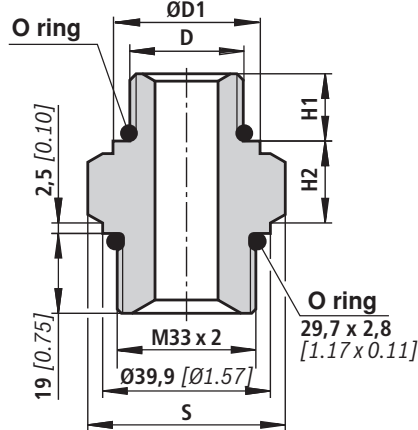

Fig. 1

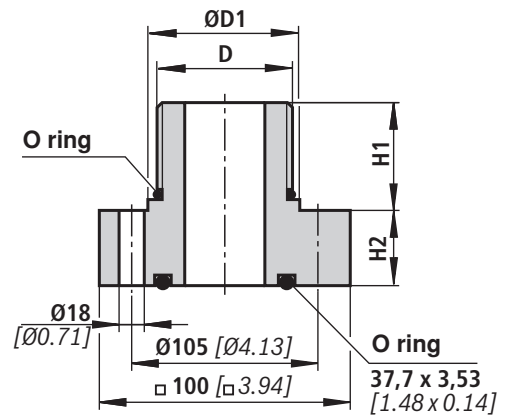

Fig. 2

Accumulator shut off block	Accumulator type	Accumulator DN	Accumulator adapter	Fig.	S	H1	H2	D	ØD1	O ring						
ABZSS 10 ABZSS 20	Diaphragm type accumulator RE 50150	0.75	S64	1	SW41 [1.61A/F]	11.4 [0.45]	18.1 [0.71]	3/4-16UNF-2A	23 [0.91]	16.36 x 2.21 [0.64 x 0.87]						
		0.16														
		0.32														
	0.5	S60	15.2 [0.60]			18.3 [0.72]	1 1/16-12UN-2A	32 [1.26]	23.0 x 3.0 [0.91 x 0.12]							
	0.7															
	1.0															
1.4	S60	15.2 [0.60]	18.3 [0.72]	1 1/16-12UN-2A	32 [1.26]	23.0 x 3.0 [0.91 x 0.12]										
2.0																
2.8																
3.5																
ABZSS 30	Bladder-type accumulator RE 50170	1.0	S60	1	SW41 [1.61A/F]	15.2 [0.60]	18.3 [0.72]	1 1/16-12UN-2A	32 [1.26]	23.0 x 3.0 [0.91 x 0.12]						
		2.5	S62								SW65 [2.55A/F]	15.2 [0.60]	20.3 [0.80]	1 5/8-12UN-2A	48 [1.89]	38.0 x 3.0 [1.50 x 0.12]
		4.0														
		6.0														
		10.0	S63								SW65 [2.55A/F]	15.2 [0.60]	20.3 [0.80]	1 7/8-12UN-2A	54 [2.13]	44.0 x 3.0 [1.73 x 0.12]
		20.0														
35.0																
50.0																
ABZSS 30	Bladder-type accumulator RE 50170	1.0	S620	2	-	15.2 [0.60]	33.8 [1.33]	1 5/8-12UN-2A	48 [1.89]	38.0 x 3.0 [1.50 x 0.12]						
		4.0														
		6.0														
		10.0	S630			15.2 [0.60]	33.8 [1.33]	1 7/8-12UN-2A	54 [2.13]	44.0 x 3.0 [1.73 x 0.12]						
		20.0														
		35.0														
50.0																

Ordering code

Short designation	ACCUMULATOR ADAPTER (SPEICHERADAPTER)	Material no. FKM	ACCUMULATOR ADAPTER (SPEICHERADAPTER)	Material no. NBR ²⁾
S60	S60V/ 1 1/16-12UN-M33x2	R900618788	S60M/ 1 1/16-12UN-M33x2	R900618799
S62	S62V/ 1 5/8-12UN-M33x2	R900618800	S62M/ 1 5/8-12UN-M33x2	R900618801
S63	S63V/ 1 7/8-12UN-M33x2	R900618803	S63M/ 1 7/8-12UN-M33x2	R900618804
S64	S64V/ 3/4-16UNF-M33x2	R900618805	S64M/ 3/4-16UNF-M33x2	R900618806
S620 ¹⁾	S620V/ 1 5/8-12UN-DN32	R900618813	S620M/ 1 5/8-12UN-DN32	R900618814
S630 ¹⁾	S630V/ 1 7/8-12UN-DN32	R900618817	S630M/ 1 7/8-12UN-DN32	R900618815

¹⁾ Scope of delivery contains 4 hexagon socket head cap screws ISO 4762-M16 x 45 - 10.9

²⁾ Special version

Safety instructions: Type tested safety valves Type DBD, component series 1X according to pressure equipment directive 97/23/EC

- Before ordering a type tested safety valve, it must be observed that with the desired **response pressure p** the maximum admissible **flow q_{Vmax}** of the safety valve is higher than the maximum possible flow of the system /accumulator to be secured.

In this connection, the corresponding regulations are to be observed!

- According to **PED 97/23/EC**, the increase in the system pressure due to the flow must not be larger than 10 % of the set response pressure (see component marking).

The maximum admissible flow specified in the component marking, q_{Vmax} , must not be exceeded.

Discharge lines of safety valves must end in a non-dangerous manner. In the discharge system, the accumulation of fluids must not be possible (see AD2000 sheet A2).

 **Application instructions must be observed!**

- In the plant, the response pressure specified in the part marking is set with a flow of 2 l/min.
- The maximum admissible flow specified in the component marking applies to applications without backpressure in the discharge line (port T).

- By removing the lead seal at the safety valve, the approval according to PED becomes void!
- In general, the requirements of the pressure equipment directive and the AD2000 data sheet A2 are to be observed!
- We recommend securing type tested safety valves against inadmissible removal from the screw-in housing/block by wiring and sealing with the housing/block (bore available in the adjustment device).

⚠ Attention!

The system pressure increases due to the increasing flow by the backpressure in the discharge line (port T). (Observe AD2000 data sheet A2, section 6.3!)

For this increase in system pressure caused by the flow not exceeding the value of 10 % of the set response pressure, the admissible flow has to be reduced depending on the backpressure in the discharge line (port T) (see diagrams below to page 18).

Maximum admissible flow q_{Vmax} depending on the backpressure p_T in the discharge line

Type DBD. 6 .1X/...E

p_A in bar [psi] p_T in bar [psi]

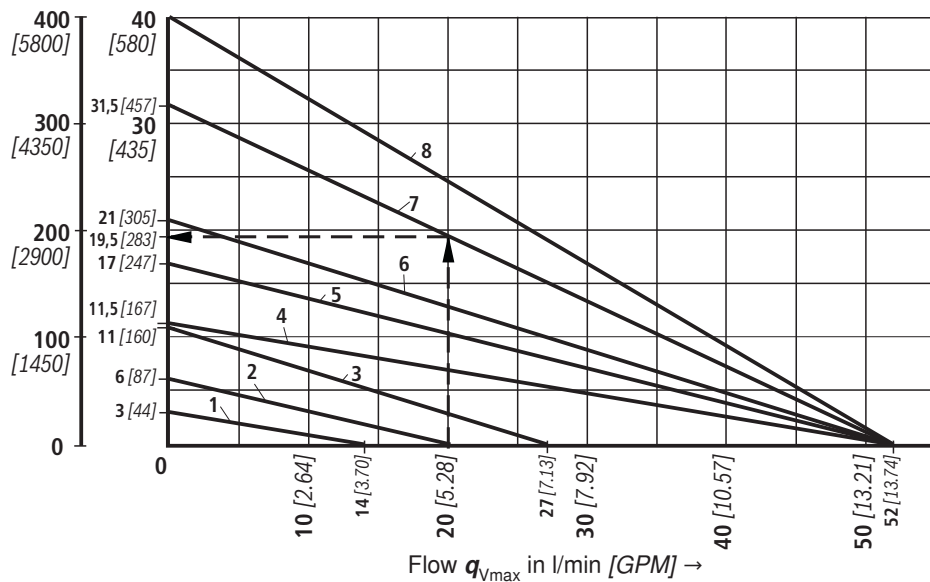

Characteristic curve	Response pressure p_A in bar [psi]
1	30 [435]
2	60 [870]
3	110 [1600]
4	115 [1670]
5	170 [2470]
6	210 [3050]
7	315 [4570]
8	400 [5800]

Characteristic curves for intermediate values can be generated by interpolation. Further explanations see page 18.

Safety instructions: Type tested safety valves Type DBD, component series 1X according to pressure equipment directive 97/23/EC

Maximum admissible flow q_{Vmax} depending on the backpressure p_T in the discharge line

Type DBD. 10 .1X/...E

p_A in bar [psi] p_T in bar [psi]

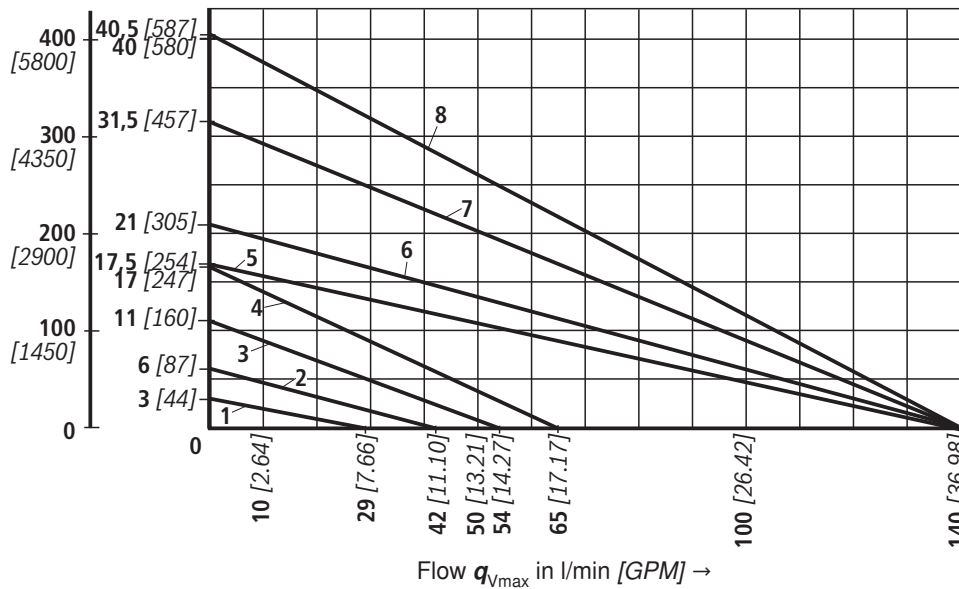

Characteristic curve	Response pressure p_A in bar [psi]
1	30 [435]
2	60 [870]
3	110 [1600]
4	170 [2470]
5	175 [2540]
6	210 [3050]
7	315 [4570]
8	400 [5800]

Characteristic curves for intermediate values can be generated by interpolation. Further explanations see page 18.

Type DBD. 20 .1X/...E

p_A in bar [psi] p_T in bar [psi]

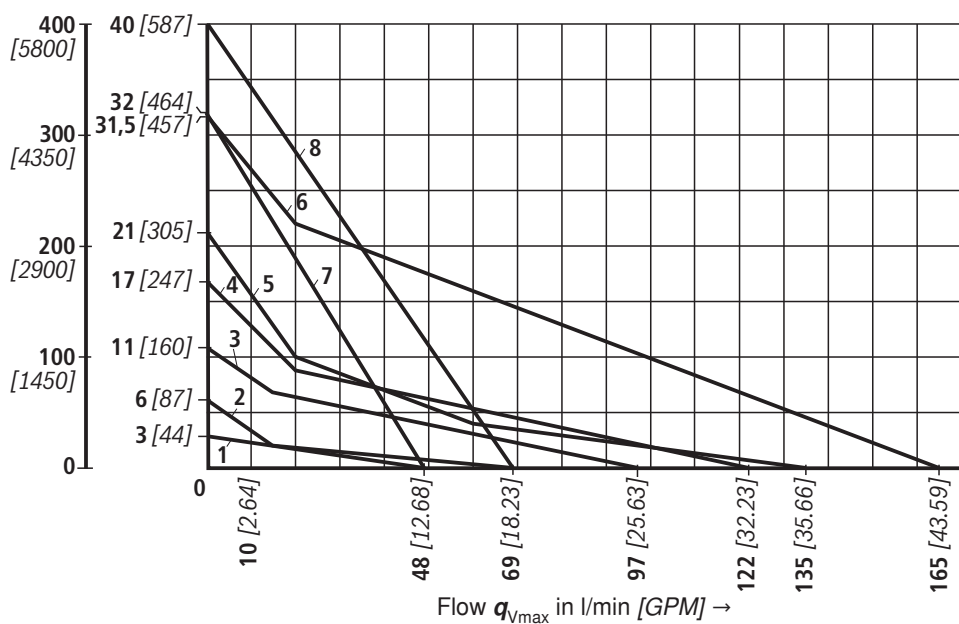

Characteristic curve	Response pressure p_A in bar [psi]
1	30 [435]
2	60 [870]
3	110 [1600]
4	170 [2470]
5	210 [3050]
6	315 [4570]
7	320 [4640]
8	400 [5800]

Characteristic curves for intermediate values can be generated by interpolation. Further explanations see page 18.

Safety instructions: Type tested safety valves Type DBD, component series 1X according to pressure equipment directive 97/23/EC

Maximum admissible flow q_{Vmax} depending on the backpressure p_T in the discharge line

Type DBD. 30 .1X/...E

p_A in bar [psi] p_T in bar [psi]

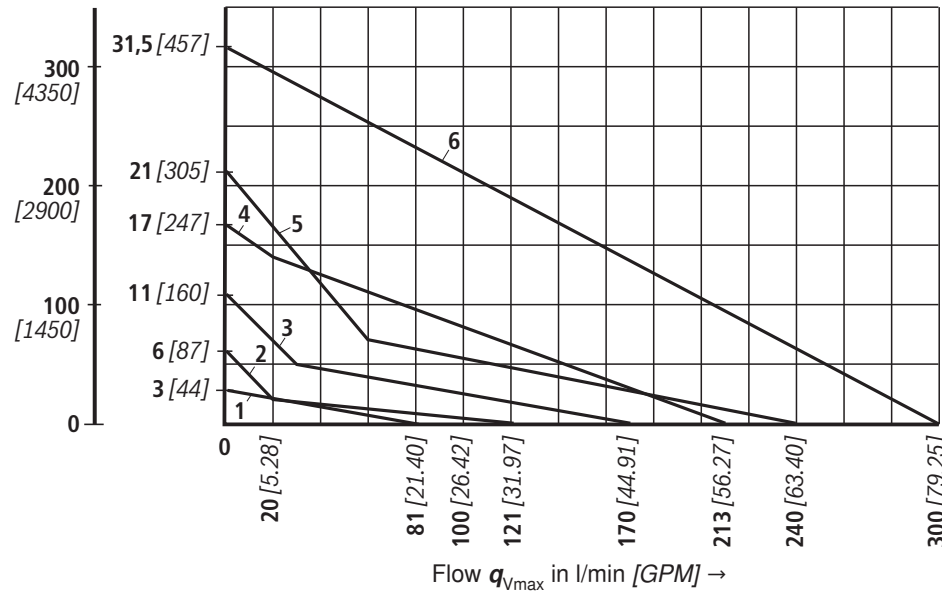

Characteristic curves	Response pressure p_A in bar [psi]
1	30 [435]
2	60 [870]
3	110 [1600]
4	170 [2470]
5	220 [3190]
6	315 [4570]

Characteristic curves for intermediate values can be generated by interpolation. Further explanations see below.

p_A = Response pressure in bar

p_T = Maximum admissible backpressure in bar (sum of all possible tank pressures; see also AD2000 - data sheet A2)

q_{Vmax} = Maximum admissible flow in l/min

PED: $p_{Tmax} = 10\% \times p_A$ (with $q_V = 0$)

Explanation of the diagrams (Example: Type DBD 6 ...E, page 16):

- Known:
- Flow of the system/accumulator to be secured $q_{Vmax} = 20$ l/min [5.28 GMP]
 - Set response pressure of the safety valve $p_A = 315$ bar [4570 psi]

Unknown: $p_{Tadmissible}$

Solution: See arrows in the diagram page 16 (Type DBD 6 ...E)

$p_{Tadmissible}$ (20 l/min; 315 bar) [5.28 GMP; 4570 psi] = 19.5 bar [283 psi]