

Device for ATORN torque recorder DM 1
with a torque of 20–200 Nm

ATORN®

Application

For mounting on e.g. a workbench. Enables torque testing directly at the workplace.

Version

- Flange plate with 1/2 inch square cutout

Art. No.	44817 740
Bore diameter	9 mm
Number of drill holes	6 PCS
Flange diameter	150 mm
Total height	85 mm
Reference circle diameter	130 mm
Square width	12.5 mm

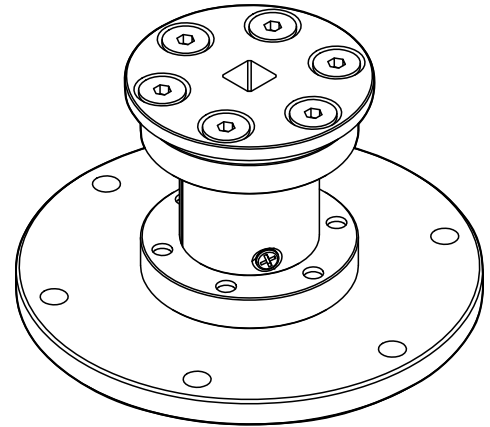

EAN-Code

4050293715705