

REV.	DATE	ECR NO.	DESCRIPTION
A	01/22/04	-	UPDATE DRAWING FORMAT
B	04/23/08	100009	MODIFY BARREL O.D., FERRULE O.D. AND I.D.

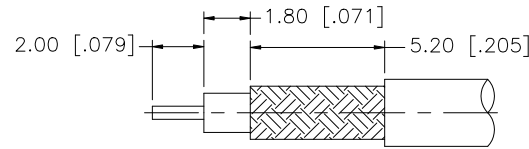

RECOMMENDED  
CABLE STRIPPING DIM'S

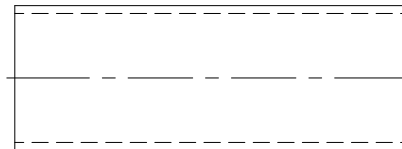
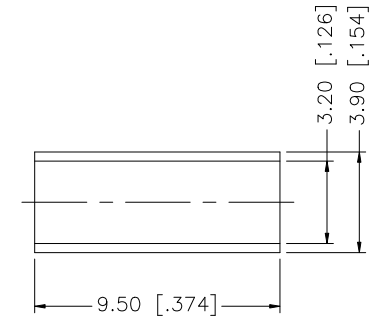
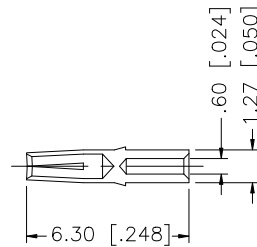
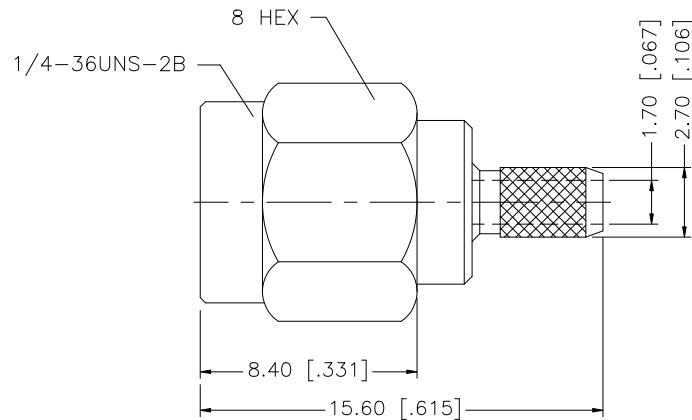

NOTES:

1. CRIMPED FERRULE HEX CRIMP SIZE .128"
2. CONTACT PIN TO SOLDER

DESCRIPTION	MATERIAL	FINISH	QTY	DO NOT SCALE DRAWING	APPROVALS	DATE	PART DESCRIPTION							
8					DRAWN	GRS	04/23/08	<h1 style="text-align: center;">Amphenol Connex</h1> <p style="text-align: center;">SMA REVERSE POLARITY CRIMP PLUG (FOR RG-174/U, 188A/U, 316/U CABLE)</p>						
7				CHECKED										
6				ISSUED										
5	HEAT SHRINK TUBING		1	SHEET	1 OF 1									
4	FERRULE	COPPER	GOLD	1										
3	CONTACT PIN	BER. COPPER	GOLD	1	PART NO.		132114RP							
2	INSULATOR	PTFE	NATURAL	1	DWG. NO.		132114RP.DWG		REV.	B	SIZE	A	SCALE	NA
1	BODY	BRASS	GOLD	1	CAD FILE		C:/132/132114RP.DWG							

UNLESS OTHERWISE SPECIFIED DIMENSIONS ARE IN MILLIMETERS. DIMENSIONS IN [ ] ARE IN INCHES AND FOR CUSTOMER REFERENCE ONLY.

UNLESS OTHERWISE SPECIFIED TOLERANCES FOR MILLIMETERS ARE:  
0.5 - 8mm ± 0.20mm  
8 - 30mm ± 0.40mm  
30 - 120mm ± 0.50mm

UNLESS OTHERWISE SPECIFIED TOLERANCES FOR INCHES ARE:  
.020 - .315 = ± 0.007"  
.315 - 1.180 = ± 0.015"  
1.180 - 4.724 = ± 0.020"