

Filter Regulator

Series AW10 to 40

Integrated filter and regulator units save space and require less piping.

Direct operated, relieving type

JIS Symbol

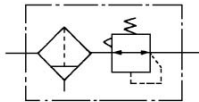

P. 14-2-72



AW20



AW40

How to Order

AW 30 F 03 BE 1N

Filter regulator

Body size

10 20 30 40

Thread type

Nil	Metric thread (M5)
N (1)	Rc
F (2)	NPT
	G



Note 1) Drain guide is NPT 1/4 (applicable to AW30 and 40), and the exhaust port for auto-drain comes with ø3/8" One-touch fitting (applicable to AW30 and AW40).

Note 2) Drain guide is G 1/4 (applicable to AW30 and AW40).

Port size

Symbol	Port size	Body size			
		10	20	30	40
M5	M5	●	—	—	—
01	1/8	—	●	—	—
02	1/4	—	●	●	●
03	3/8	—	—	●	●
04	1/2	—	—	—	●
06	3/4	—	—	—	●

Option

Symbol	Description	Applicable model
1 (5)	0.02 to 0.2 MPa setting	AW10 to 40
2	Metal bowl	AW10 to 40
6	Nylon bowl	AW10 to 40
8	Metal bowl with level gauge	AW30/40
C	With bowl guard	AW20
J (6)	Drain guide 1/4	AW30/40
N	Non-relieving	AW10 to 40
R	Flow direction: Right → Left	AW10 to 40
W	Drain cock with barb fitting: ø6 x ø4 nylon tubing	AW30/40
Z (7)	Name plate, caution plate for bowl, and pressure gauge in imperial units (PSI, °F)	AW10 to 40



* When more than one specification is required, indicate in alphanumeric order.

Note 5) The only difference from the standard specifications is the adjusting spring for the regulator. It does not restrict the setting of 0.2 MPa or more.

Note 6) Without a valve function.

Note 7) For M5 and NPT thread types. This product is for overseas use only according to the new Measurement Law. (The SI unit type is provided for use in Japan.)

Accessory (3)

Symbol	Description	Applicable model
Nil	—	—
B	With bracket	AW10 to 40
C	Float type auto-drain (N.C.) (4)	AW10 to 40
D	Float type auto-drain (N.O.) (4)	AW30/40
E	With square embedded type pressure gauge (With limit indicator)	AW20 to 40
G	With round pressure gauge (Without limit indicator)	AW10
	With round pressure gauge (With limit indicator)	AW20 to 40
H	With set nut (For panel mount)	AW10 to 40



Note 3) Optional parts are not assembled and are supplied loose at the time of shipment (except options C, D and E).

Note 4) Applicable tubing O.D for auto drain connection should be ø3/8" in case NPT thread port is chosen.

Accessory/Optional Specifications Combinations

⊙: Combination available

■: Combination not available

○: Varies depending on the model

△: Available only with NPT thread

Accessory/Optional specifications	Combination	Symbol	Accessory							Optional specifications							Applicable filter regulator				
			B	C	D	E	G	H	1	2	6	8	C	J	N	R	W	Z	AW10	AW20	AW30 to 40
Accessory	With bracket (With set nut)	B	⊙	○	○	○	○	○	○	○	○	○	○	○	○	○	○	○	○	○	○
	Float type auto-drain (N.C.)	C	⊙	■	○	○	○	○	○	○	○	○	○	○	○	○	○	○	○	○	○
	Float type auto-drain (N.O.)	D	⊙	■	○	○	○	○	○	○	○	○	○	○	○	○	○	○	○	○	○
	Square embedded type pressure gauge	E	⊙	○	○	○	○	○	○	○	○	○	○	○	○	○	○	○	○	○	○
	Round pressure gauge	G	⊙	○	○	○	○	○	○	○	○	○	○	○	○	○	○	○	○	○	○
	With set nut (For panel mount)	H	⊙	○	○	○	○	○	○	○	○	○	○	○	○	○	○	○	○	○	○
Optional specifications	0.02 to 0.2 MPa setting	-1	⊙	○	○	○	○	○	○	○	○	○	○	○	○	○	○	○	○	○	○
	Metal bowl	-2	⊙	○	○	○	○	○	○	○	○	○	○	○	○	○	○	○	○	○	○
	Nylon bowl	-6	⊙	○	○	○	○	○	○	○	○	○	○	○	○	○	○	○	○	○	○
	Metal bowl with level gauge	-8	⊙	○	○	○	○	○	○	○	○	○	○	○	○	○	○	○	○	○	○
	With bowl guard	-C	⊙	○	○	○	○	○	○	○	○	○	○	○	○	○	○	○	○	○	○
	Drain guide 1/4	-J	⊙	○	○	○	○	○	○	○	○	○	○	○	○	○	○	○	○	○	○
	Non-relieving type	-N	⊙	○	○	○	○	○	○	○	○	○	○	○	○	○	○	○	○	○	○
	Flow direction: Right → Left	-R	⊙	○	○	○	○	○	○	○	○	○	○	○	○	○	○	○	○	○	○
	Drain cock with barb fitting: ø6 x ø4 nylon tubing	-W	⊙	○	○	○	○	○	○	○	○	○	○	○	○	○	○	○	○	○	○
	Name plate, caution plate for bowl, and pressure gauge in imperial units (PSI, °F)	-Z	△	△	△	△	△	△	△	△	△	△	△	△	△	△	△	△	△	△	△

F.R.L.

AV

AU

AF

AR

IR

VEX

AMR

ITV

IC

VBA

VE□

VY1

G

PPA

AL

Series AW10 to 40

Standard Specifications

Model	AW10	AW20	AW30	AW40	AW40-06
Port sizes	M5 x 0.8	1/8, 1/4	1/4, 3/8	1/4, 3/8, 1/2	3/4
Fluid	Air				
Proof pressure	1.5 MPa				
Maximum operating pressure	1.0 MPa				
Set pressure range	0.05 to 0.7 MPa	0.05 to 0.85 MPa			
Pressure gauge port size (1)	Rc 1/16 (2)	Rc, NPT, G 1/8	Rc, NPT, G 1/8	Rc, NPT, G 1/4	Rc, NPT, G 1/4
Relief pressure	Set pressure + 0.05 MPa (3) (at relief flow rate of 0.1 l/min (ANR))				
Ambient and fluid temperature	-5 to 60°C (With no freezing)				
Nominal filtration rating	5 µm				
Drain capacity (cm ³)	2.5	8	25	45	45
Bowl material	Polycarbonate				
Bowl guard	—	Option	Standard		
Construction	Relieving type				
Weight (kg)	0.09	0.32	0.40	0.72	0.75

Note 1) Pressure gauge connection threads are not required for regulators with a square embedded type pressure gauge (AW20 to AW40).

Note 2) Use a bushing (part no: 131368) when connecting R 1/8 pressure gauge to R 1/16 gauge port.

Note 3) Not applicable to AW10.

Accessory Part No.

Applicable model		AW10	AW20	AW30	AW40	AW40-06	
Accessory							
Bracket assembly (1)		AR10P-270AS	AW20P-270AS	AR30P-270AS	AR40P-270AS	AR40P-270AS	
Set nut		AR10P-260S	AR20P-260S	AR30P-260S	AR40P-260S	AR40P-260S	
Pressure gauge (2)	1.0 MPa	Round Type	G27-10-R1	G36-10-□01	G36-10-□01	G46-10-□02	G46-10-□02
		Square embedded type (4)	—	GC3-10AS	GC3-10AS	GC3-10AS	GC3-10AS
	0.2 MPa	Round Type	G27-10-R1 (3)	G36-2-□01	G36-2-□01	G46-2-□02	G46-2-□02
		Square embedded type (4)	—	GC3-2AS	GC3-2AS	GC3-2AS	GC3-2AS
Float type auto-drain (5)	N.O.	—	—	AD38	AD38N(6)	AD48	AD48N(6)
	N.C.	AD17	AD27	AD37	AD37N(6)	AD47	AD47N(6)

Note 1) Assembly includes a bracket and set nuts.

Note 2) □ in part numbers for a round pressure gauge indicates a type of connection thread. No indication is necessary for R; however, indicate N for NPT. Please contact SMC regarding the connection thread NPT and supply of the pressure gauge for PSI unit specifications.

Note 3) For 1 MPa.

Note 4) Includes one O-ring and 2 mounting screws.

Note 5) Minimum operating pressure: N.O. type—0.1 MPa; N.C. type—0.1 MPa (AD17/27) and 0.15 MPa (AD37/47). Please contact SMC regarding the specifications for PSI unit and °F.

Note 6) When "N" is specified in the end of part number of auto-drain, applicable tubing O.D should be ø3/8".

⚠ Precautions

Be sure to read before handling. Refer to pages 14-21-3 to 14-21-4 for Safety Instructions and Common Precautions.

Selection

⚠ Warning

- Residual pressure release (outlet pressure release) is not completed by releasing inlet pressure. To release residual pressure, use a filter regulator with a back flow mechanism.

Maintenance

⚠ Warning

- Replace the element every 2 years or when the pressure drop becomes 0.1 MPa, whichever comes first, to prevent damage to the element.

Mounting & Adjustment

⚠ Warning

- Set the regulator while checking the displayed values of the inlet and outlet pressure gauges. Turning the knob excessively can cause damage to the internal parts.
- The pressure gauge indicated with regulators for 0.02 to 0.2 MPa setting is for 0.2 MPa use only. Exceeding 0.2 MPa of pressure can damage the gauge.
- Do not use tools on the pressure regulator knob as this may cause damage. It must be operated manually.

⚠ Caution

- Be sure to unlock the knob before adjusting the pressure and lock it after setting the pressure. Failure to follow this procedure can cause damage to the knob and the outlet pressure may fluctuate.

- Pull the pressure regulator knob to unlock. (You can visually verify this with the "orange mark" that appears in the gap.)
- Push the pressure regulator knob to lock. When the knob is not easily locked, turn it left and right a little and then push it (when the knob is locked, the "orange mark" will disappear).



- A knob cover is available to prevent careless operation of the knob. Refer to page 14-2-6 for details.

Filter Regulator Series AW10 to 40

Flow Characteristics (Representative values)

Condition: Inlet pressure 0.7 MPa

AW10 M5

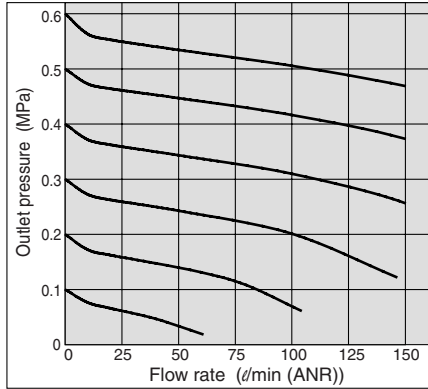

AW30 Rc 3/8

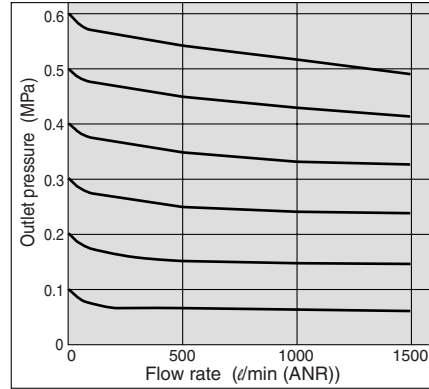

AW40-06 Rc 3/4

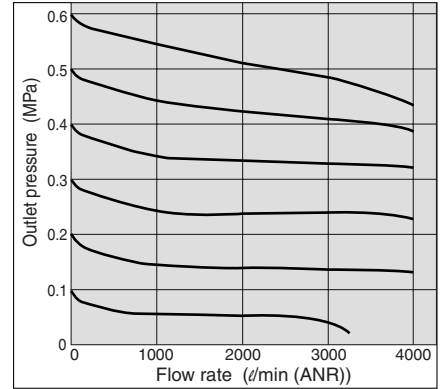

AW20 Rc 1/4

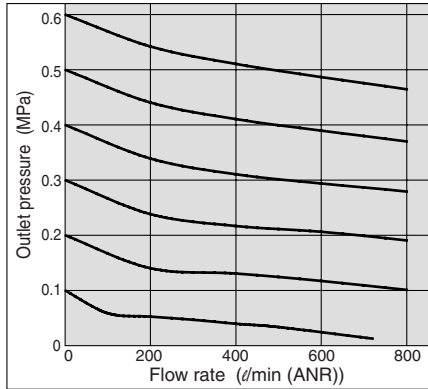

AW40 Rc 1/2

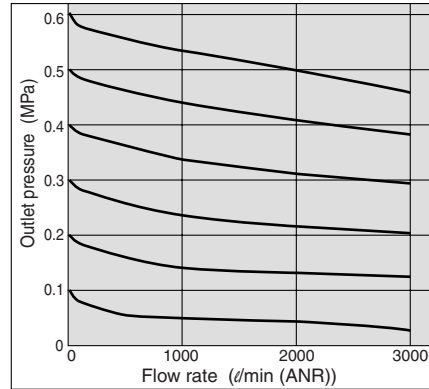

Pressure Characteristics (Representative value)

Conditions: Inlet pressure 0.7 MPa; Outlet pressure 0.2 MPa; Flow rate 20 l/min (ANR)

AW10

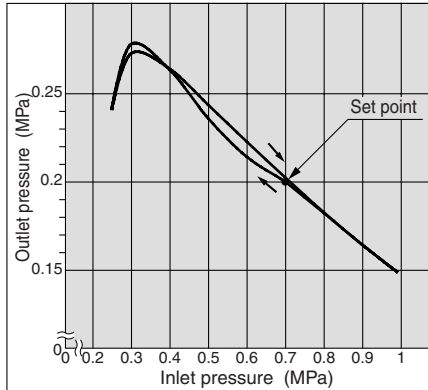

AW30

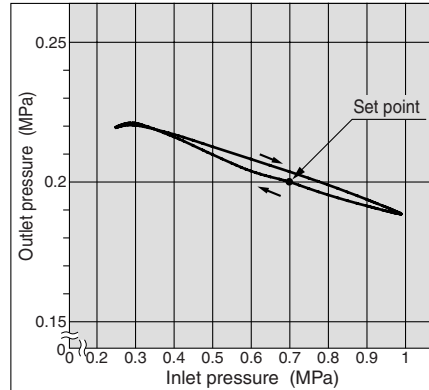

AW40-06

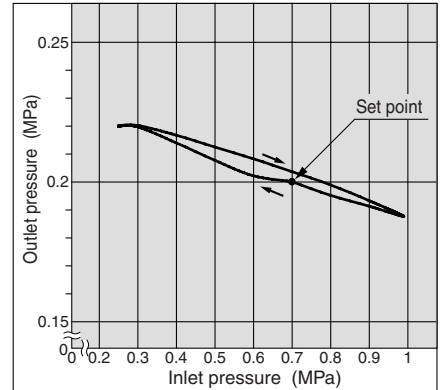

AW20

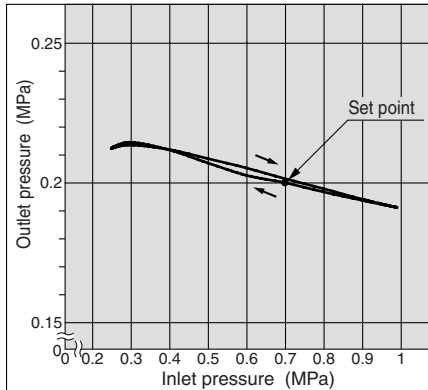

AW40

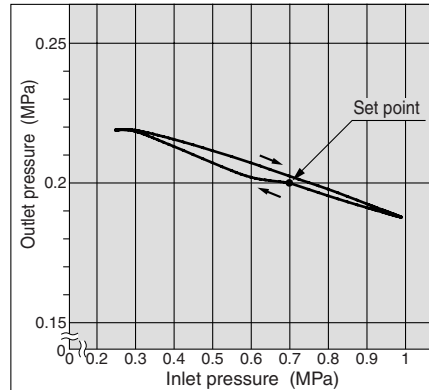

F.R.L.

AV

AU

AF

AR

IR

VEX

AMR

ITV

IC

VBA

VE □

VY1

G

PPA

AL

Series AW10 to 40

Construction

JIS Symbol

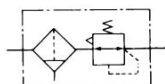

AW10

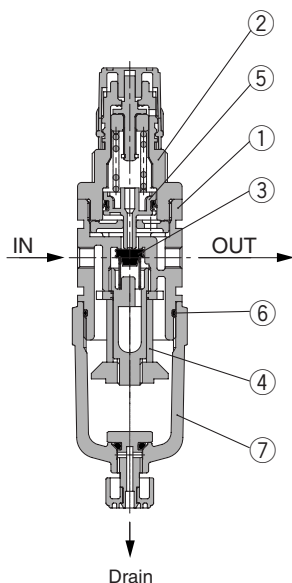

AW20

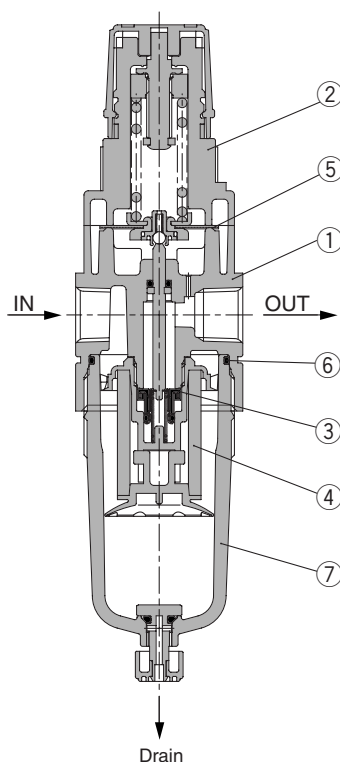

AW30/40

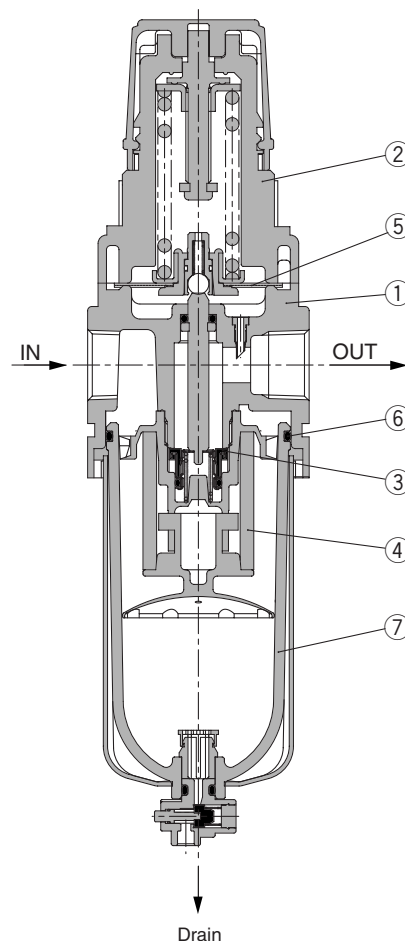

Component Parts

No.	Description	Material			Note
		AW10/20	AW30	AW40/40-06	
①	Body	Zinc die-casted	Aluminum die-casted		Platinum silver
②	Bonnet	Polyacetal			Black

Replacement Parts

No.	Description	Material	Part no.				
			AW10	AW20	AW30	AW40	AW40-06
③	Valve assembly	Stainless steel Brass, HNBR	AR10P-090S	AW20P-360AS ⁽⁴⁾	AW30P-360AS ⁽⁴⁾	AW40P-360AS ⁽⁴⁾	AW40P-380AS ⁽⁴⁾
④	Filter element	Non-woven fabric	AF10P-060S	AF20P-060S	AF30P-060S	AF40P-060S	AF40P-060S
⑤	Diaphragm assembly	Weatherability NBR	AR10P-150AS ⁽¹⁾	AR20P-150AS	AR30P-150AS	AR40P-150AS	AR40P-150AS
⑥	Bowl O-ring	NBR	C1SFP-260S	C2SFP-260S	C3SFP-260S	C4SFP-260S	C4SFP-260S
⑦	Bowl assembly ⁽²⁾	PC	C1SF	C2SF	C3SF ⁽³⁾	C4SF ⁽³⁾	C4SF ⁽³⁾

- Note 1) AW10 is a piston and a gasket (KSYP-13) type assembly.
 Note 2) Including O-ring. Please contact SMC regarding the bowl assembly supply for PSI and °F unit specifications.
 Note 3) Bowl assembly includes a bowl guard (steel band material).
 Note 4) Assembly includes valve assembly, valve spring and stem assembly.

Filter Regulator Series AW10 to 40

Dimensions

AW10/20

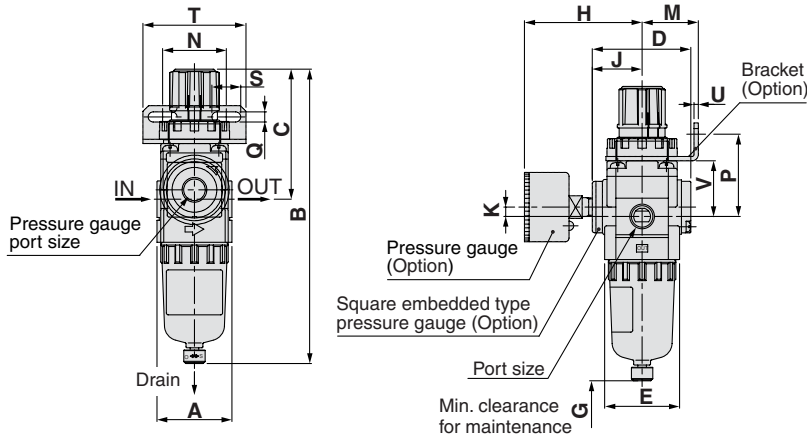

Panel fitting dimension

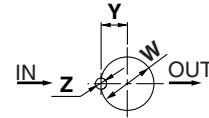
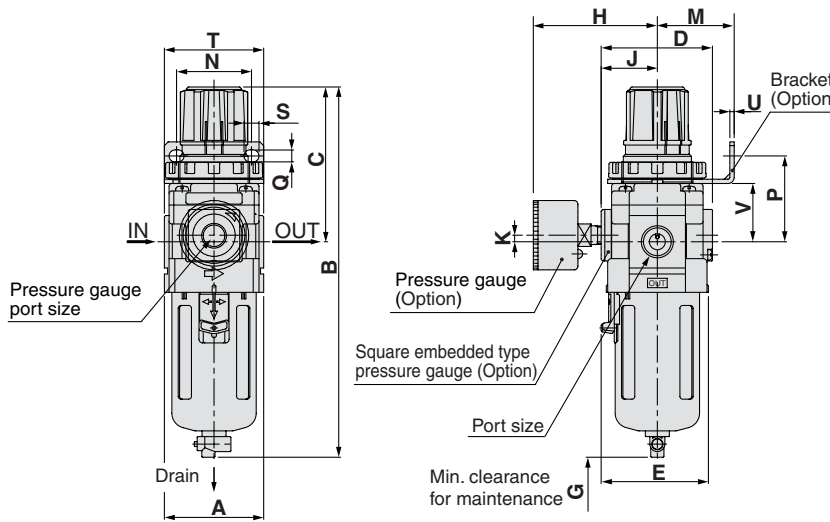

Plate thickness
AW10, AW20: Max. 3.5

AW30/40



Panel fitting dimension

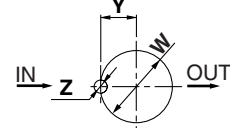

Plate thickness
AW30: Max. 3.5
AW40: 5

Applicable model	AW10, AW20		AW30, AW40, AW40-06				
	With auto-drain (N.C.)	Metal bowl	With auto-drain (N.O./N.C.)	Metal bowl	Metal bowl with level gauge	With drain guide	Drain cock with barb fitting
Optional specifications			 N.O.: Black N.C.: Gray ø10 One-touch fitting			 Width across flats 17	 Barb fitting Applicable tubing: T0604

(mm)

Model	Port size	Standard specifications					Accessory specifications															
		A	B	C	D	E	G	With pressure gauge			Bracket mounting size					Panel mount				With auto-drain		
								H	J	K	M	N	P	Q	S	T	U	V	W	Y	Z	B
AW10	M5 x 0.8	25	108	48	25	28	25	26	—	0	25	28	30	4.5	6.5	40	2	18	18.5	—	—	125
AW20	1/8, 1/4	40	160	73	52	40	40	63	27	5	30	34	44	5.4	15.4	55	2.3	30	28.5	14	6	177
AW30	1/4, 3/8	53	201	86	59	57	55	66	30.5	3.5	41	40	46	6.5	8	53	2.3	31	38.5	19	7	242
AW40	1/4, 3/8, 1/2	70	239	92	75	73	80	76	38.5	1.5	50	54	54	8.5	10.5	70	2.3	35.5	42.5	21	7	278
AW40-06	3/4	75	242	93	75	73	80	76	38.5	1.2	50	54	56	8.5	10.5	70	2.3	37	42.5	21	7	281

Model	Optional specifications			
	With barb fitting	With drain guide	Metal bowl	Metal bowl with level gauge
	B	B	B	B
AW10	—	—	107	—
AW20	—	—	160	—
AW30	209	208	214	234
AW40	247	246	252	272
AW40-06	250	249	255	275

- F.R.L.
- AV
- AU
- AF
- AR
- IR
- VEX
- AMR
- ITV
- IC
- VBA
- VE□
- VY1
- G
- PPA
- AL

Filter Regulator with Back Flow Mechanism Series **AW20K/30K/40K**

How to Order



AW40K



AW20K

AW 30 K F 03 BE 1N

Filter regulator

Body size

20 30 40

With back flow mechanism

Note) AW10 comes with a back flow mechanism as a standard feature. If the set pressure is not exceeding 0.15 MPa, back flow may not occur. When a back flow mechanism is required with a set pressure of less than 0.15 MPa, please contact SMC.

Thread type

Nil	Rc
N (1)	NPT
F (2)	G

Note 1) Drain guide is NPT 1/4 (applicable to AW30K and 40K), and the exhaust port for auto-drain comes with ø3/8" One-touch fitting (applicable to AW30K and AW40K).

Note 2) Drain guide is G 1/4 (applicable to AW30K and AW40K).

Port size

Symbol	Port size	Body size		
		20	30	40
01	1/8	●	—	—
02	1/4	●	●	—
03	3/8	—	●	●
04	1/2	—	—	●
06	3/4	—	—	●

Option

Symbol	Description	Applicable model
1 (4)	0.02 to 0.2 MPa setting	AW20K to 40K
2	Metal bowl	AW20K to 40K
6	Nylon bowl	AW20K to 40K
8	Metal bowl with level gauge	AW30K/40K
C	With bowl guard	AW20K
J (5)	Drain guide 1/4	AW30K/40K
N	Non-relieving type	AW20K to 40K
R	Flow direction: Right → Left	AW20K to 40K
W	Drain cock with barb fitting: ø6 x ø4 nylon tubing	AW30K/40K
Z (6)	Name plate, caution plate for bowl, and pressure gauge in imperial units (PSI, °F)	AW20K to 40K

* When more than one specification is required, indicate in alphanumeric order.
Note 4) The only difference from the standard specifications is the adjusting spring for the regulator. It does not restrict the setting of 0.2 MPa or more.
Note 5) Without a valve function.
Note 6) For NPT thread type. This product is for overseas use only according to the new Measurement Law. (The SI unit type is provided for use in Japan.)

Accessory (3)

Symbol	Description	Applicable model
Nil	—	—
B	With bracket	AW20K to 40K
C	Float type auto-drain (N.C.) (2)	AW20K to 40K
D	Float type auto-drain (N.O.) (2)	AW30K/40K
E	With square embedded type pressure gauge (With limit indicator)	AW20K to 40K
G	With round pressure gauge (With limit indicator)	AW20K to 40K
H	With set nut (For panel mount)	AW20K to 40K

Note 1) Optional parts are not assembled and are supplied loose at the time of shipment (except options C, D and E).
Note 2) Applicable tubing O.D for auto drain connection should be ø3/8" in case NPT thread port is chosen.

Standard Specifications

Model	AW20K	AW30K	AW40K	AW40K-06
Port sizes	1/8, 1/4	1/4, 3/8	1/4, 3/8, 1/2	3/4
Fluid	Air			
Proof pressure	1.5 MPa			
Maximum operating pressure	1.0 MPa			
Set pressure range (1)	0.05 to 0.85 MPa			
Pressure gauge port size (2)	Rc, NPT, G 1/8	Rc, NPT, G 1/8	Rc, NPT, G 1/4	Rc, NPT, G 1/4
Relief pressure	Set pressure + 0.05 MPa (at relief flow rate of 0.1/min (ANR))			
Ambient and fluid temperature	-5 to 60°C (With no freezing)			
Nominal filtration rating	5 µm			
Drain capacity (cm ³)	8	25	45	45
Bowl material	Polycarbonate			
Bowl guard	Option	Standard		
Construction	Relieving type			
Weight (kg)	0.32	0.40	0.72	0.75

Note 1) Set the inlet pressure 0.05 MPa or higher than the set pressure.
Note 2) Pressure gauge connection threads are not required for regulators with a square embedded type pressure gauge (AW20K to AW40K).

Accessory Part No.

Applicable model		AW20K	AW30K	AW40K	AW40K-06	
Accessory						
Bracket assembly (1)		AW20P-270AS	AR30P-270AS	AR40P-270AS	AR40P-270AS	
Set nut		AR20P-260S	AR30P-260S	AR40P-260S	AR40P-260S	
Pressure gauge (2)	1.0 MPa	Round type	G36-10-□01	G36-10-□01	G46-10-□02	G46-10-□02
		Square embedded type (3)	GC3-10AS	GC3-10AS	GC3-10AS	GC3-10AS
	0.2 MPa	Round type	G36-2-□01	G36-2-□01	G46-2-□02	G46-2-□02
		Square embedded type (3)	GC3-2AS	GC3-2AS	GC3-2AS	GC3-2AS
Float type auto-drain (4)	N.O.	—	AD38 AD38N(5)	AD48 AD48N(5)	AD48 AD48N(5)	
	N.C.	AD27	AD37 AD37N(5)	AD47 AD47N(5)	AD47 AD47N(5)	

Note 1) Assembly includes a bracket and set nuts.
Note 2) □ in part numbers for a round pressure gauge indicates a type of connection thread. No indication is necessary for R; however, indicate N for NPT. Please contact SMC regarding the connection thread NPT and pressure gauge supply for PSI unit specifications.
Note 3) Includes one O-ring and 2 mounting screws.
Note 4) Minimum operating pressure: N.O. type-0.1 MPa; N.C. type-0.1 MPa (AD27) and 0.15 MPa (AD37/47). Please contact SMC regarding the specifications for PSI unit and °F.
Note 5) When "N" is specified in the end of part number of auto-drain, applicable tubing O.D should be ø3/8".

JIS Symbol

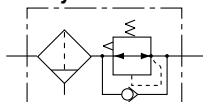

Circuit Diagram

When the air supply is cut off and releasing the inlet pressure to the atmosphere, the residual pressure release of the outlet side can be ensured for a safety purpose.

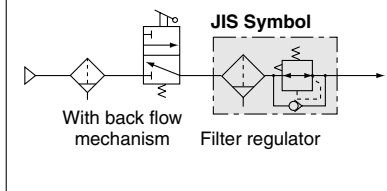

Filter Regulator with Back Flow Mechanism Series AW20K/30K/40K

Flow Characteristics (Representative values)

Condition:
Inlet pressure 0.7 MPa

AW20K Rc 1/4

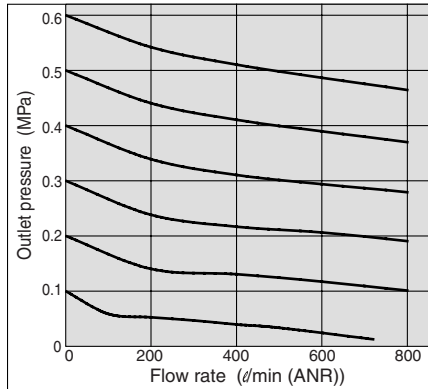

AW30K Rc 3/8

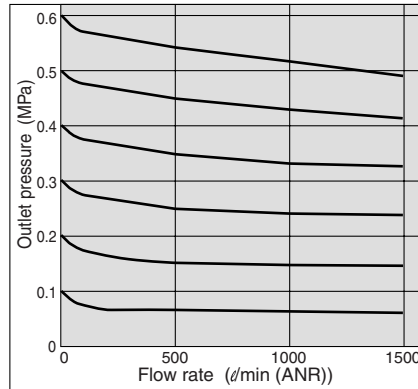

AW40K Rc 1/2

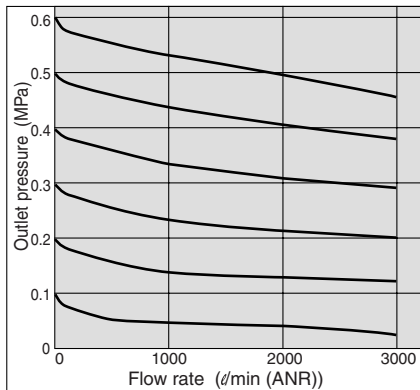

AW40K-06 Rc 3/4

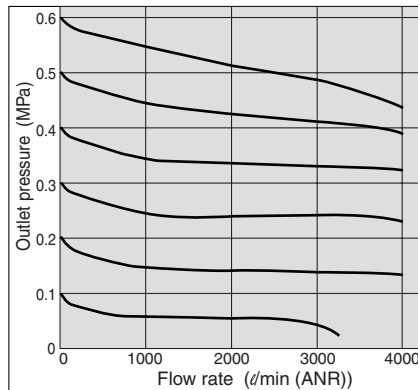

Conditions:
Inlet pressure 0.7 MPa
Outlet pressure 0.2 MPa
Flow rate 20 l/min (ANR)

Pressure Characteristics (Representative values)

AW20K

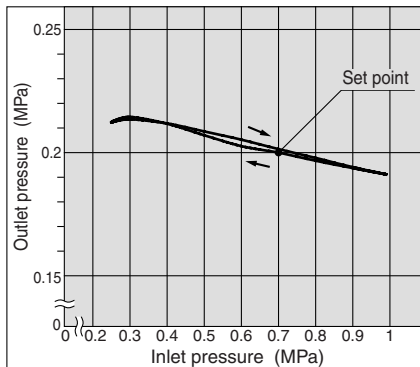

AW40K

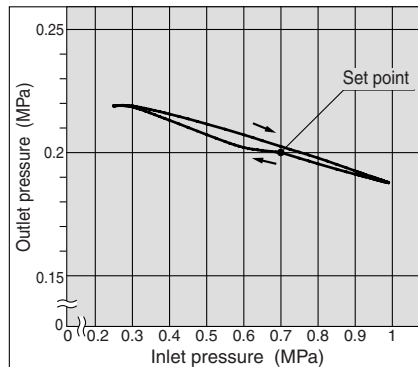

AW30K

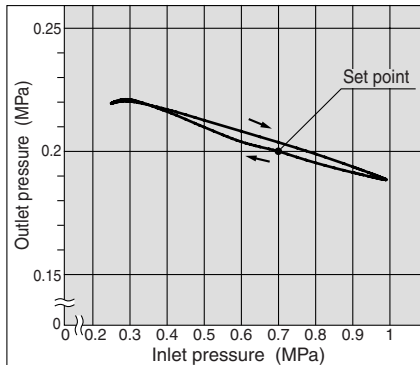

AW40K-06

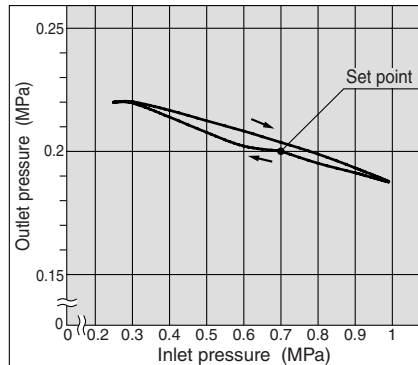

⚠ Precautions

Be sure to read before handling.
Refer to pages 14-21-3 to 14-21-4 for Safety Instructions and Common Precautions.

Mounting & Adjustment

⚠ Warning

1. Set the regulator while checking the displayed values of the inlet and outlet pressure gauges. Turning the knob excessively can cause damage to the internal parts.
2. The pressure gauge included with regulators for 0.02 to 0.2 MPa setting is for up to 0.2 MPa use. Exceeding 0.2 MPa of pressure can damage the gauge.
3. Do not use tools on the pressure regulator knob as this may cause damage. It must be operated manually.

⚠ Caution

1. Be sure to unlock the knob before adjusting the pressure and lock it after setting the pressure.
Failure to follow this procedure can cause damage to the knob and the outlet pressure may fluctuate.
- Pull the pressure regulator knob to unlock. (You can visually verify this with the "orange mark" that appears in the gap.)
- Push the pressure regulator knob to lock. When the knob is not easily locked, turn it left and right a little and then push it (when the knob is locked, the "orange mark", i.e., the gap will disappear).



2. A knob cover is available to prevent careless operation of the knob. Refer to page 14-2-6 for details.

Maintenance

⚠ Warning

1. Replace the element every 2 years or when the pressure drop becomes 0.1 MPa, whichever comes first to prevent damage to the element.

F.R.L.

AV

AU

AF

AR

IR

VEX

AMR

ITV

IC

VBA

VE□

VY1

G

PPA

AL

Series AW20K/30K/40K

Working Principle

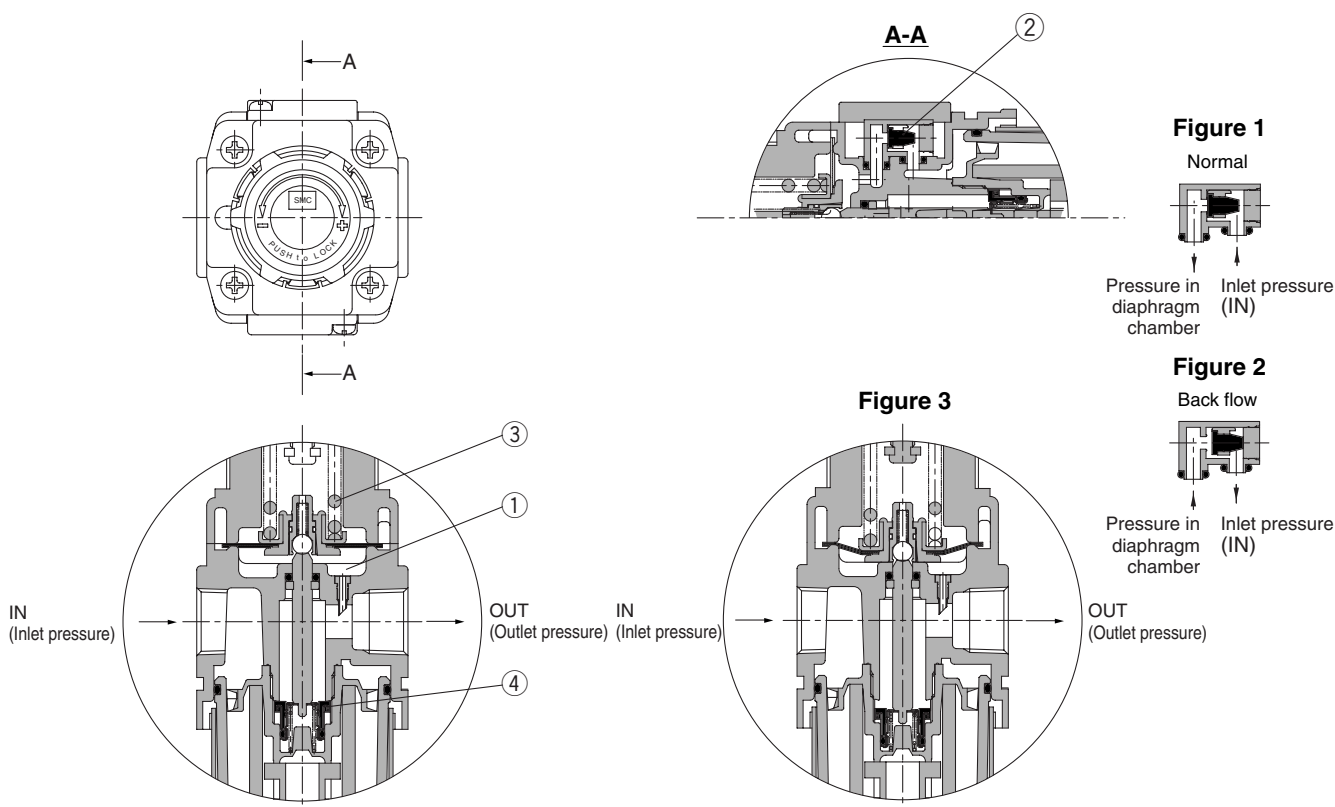

When the inlet pressure (P1) is higher than the set pressure, the check valve ② closes and operates as a normal regulator (Figure 1).

When the inlet pressure (P1) is shut off and released, the check valve ②, opens and the pressure in the diaphragm chamber ① is released into the inlet side (Figure 2).

This lowers the pressure in the diaphragm chamber ①, and the force generated by pressure regulator spring ③ lifts the diaphragm. Valve ④ opens through the stem, and the outlet pressure is released to the inlet side (Figure 3).

Construction

AW20K to 40K

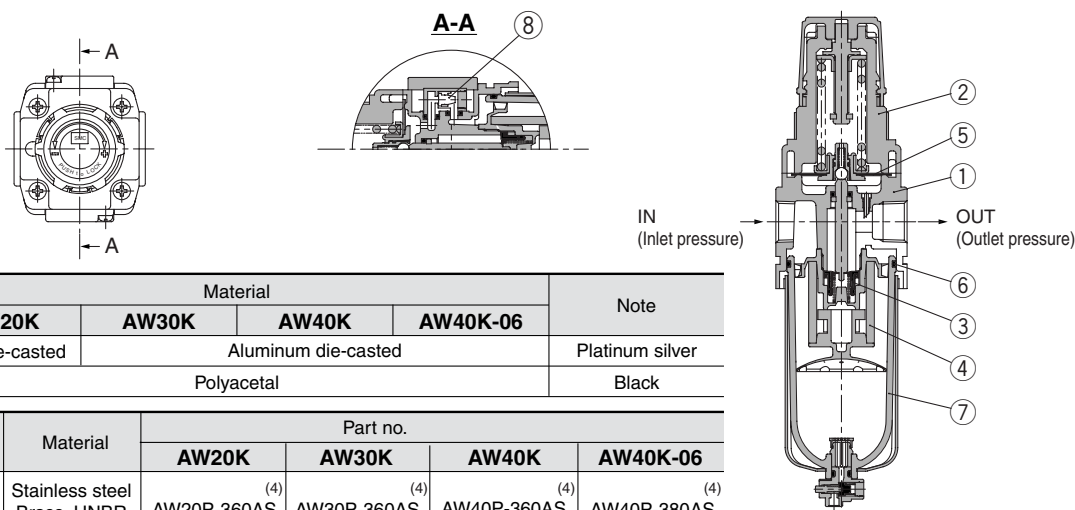

Component Parts

No.	Description	Material				Note
		AW20K	AW30K	AW40K	AW40K-06	
①	Body	Zinc die-casted	Aluminum die-casted			Platinum silver
②	Bonnet	Polyacetal				Black

No.	Description	Material	Part no.			
			AW20K	AW30K	AW40K	AW40K-06
③	Valve assembly	Stainless steel Brass, HNBR	AW20P-360AS ⁽⁴⁾	AW30P-360AS ⁽⁴⁾	AW40P-360AS ⁽⁴⁾	AW40P-380AS ⁽⁴⁾
④	Filter element	Non-woven fabric	AF20P-060S	AF30P-060S	AF40P-060S	AF40P-060S
⑤	Diaphragm assembly	Weatherability NBR	AR20P-150AS	AR30P-150AS	AR40P-150AS	AR40P-150AS
⑥	Bowl O-ring	NBR	C2SFP-260S	C3SFP-260S	C4SFP-260S	C4SFP-260S
⑦	Bowl assembly ⁽¹⁾	PC	C2SF	C3SF ⁽²⁾	C4SF ⁽²⁾	C4SF ⁽²⁾
⑧	Check valve assembly ⁽³⁾	POM, PBT	AR20KP-020AS	AR20KP-020AS	AR20KP-020AS	AR20KP-020AS

Note 1) Including O-ring. Please contact SMC regarding the bowl assembly supply for PSI and °F unit specifications.

Note 2) Bowl assembly includes a bowl guard (steel band material).

Note 3) Check valve assembly includes check valve cover, check valve body assembly and screws (2 pcs.).

Note 4) Assembly includes valve assembly, valve spring and stem assembly.

Filter Regulator with Back Flow Mechanism Series AW20K/30K/40K

Dimensions

AW20K/30K/40K

Panel fitting dimension

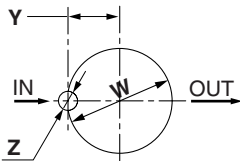
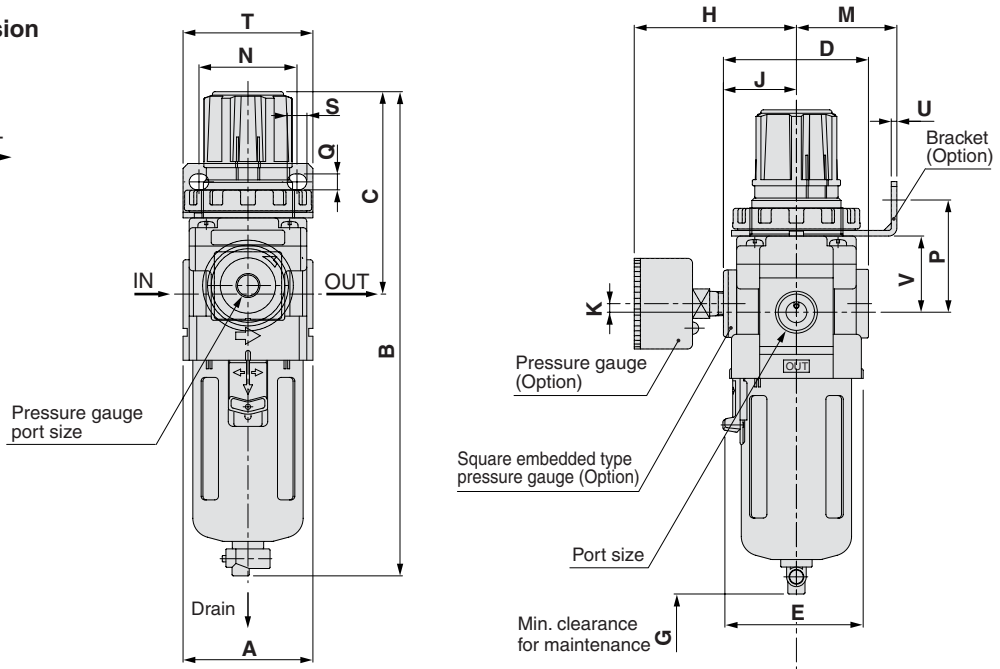

Plate thickness
AW20K, 30K: Max. 3.5
AW40K: Max. 5



Applicable model	AW20K		AW30K, AW40K, AC40K-06				
	With auto-drain (N.C.)	Metal bowl	With auto-drain (N.O./N.C.)	Metal bowl	Metal bowl with level gauge	With drain guide	Drain cock with barb fitting
Optional specifications	 M5 x 0.8 B	 B	 N.O.: Black N.C.: Gray ø10 One-touch fitting B	 B	 B	 1/4 Width across flats 17 B	 Barb fitting Applicable tubing: T0604 B

(mm)

Model	Port size	Standard specifications																Accessory specifications									
		Standard specifications										With pressure gauge						Bracket mounting size				Panel mount				With auto-drain	
		A	B	C	D	E	G	H	J	K	M	N	P	Q	S	T	U	V	W	Y	Z	B					
AW20K	1/8, 1/4	40	160	73	52	40	40	63	27	5	30	34	44	5.4	15.4	55	2.3	30	28.5	14	6	177					
AW30K	1/4, 3/8	53	201	86	59	57	55	66	30.5	3.5	41	40	46	6.5	8	53	2.3	31	38.5	19	7	242					
AW40K	1/4, 3/8, 1/2	70	239	92	75	73	80	76	38.5	1.5	50	54	54	8.5	10.5	70	2.3	35.5	42.5	21	7	278					
AW40K-06	3/4	75	242	93	75	73	80	76	38.5	1.2	50	54	56	8.5	10.5	70	2.3	37	42.5	21	7	281					

Model	Port size	Optional specifications			
		With barb fitting	With drain guide	Metal bowl	Metal bowl with level gauge
		B	B	B	B
AW20K	1/8, 1/4	—	—	160	—
AW30K	1/4, 3/8	209	208	214	234
AW40K	1/4, 3/8, 1/2	247	246	252	272
AW40K-06	3/4	250	249	255	275

F.R.L.

AV

AU

AF

AR

IR

VEX

AMR

ITV

IC

VBA

VE□

VY1

G

PPA

AL

Filter Regulator *Series AW20 to 40*

Made to Order Specifications:

Please contact SMC for detailed dimensions, specifications, and lead times.

1. Special Temperature Environment

Special materials are used in the manufacturing of seals and resin parts to allow them to withstand various temperature conditions in cold or tropical (hot) regions.

Specifications

Part no.	-X430	-X440
Environment	Low temperature	High temperature
Ambient temperature	-30 to 60°C	-5 to 80°C
Fluid temperature	-5 to 60°C (With no freezing)	
Material	Rubber parts	Special NBR
	Main parts	Aluminum die-casted

Applicable Model

Model	AW30	AW40	AW40-06
Port size	1/4, 3/8	1/4, 3/8, 1/2	3/4

2. High Pressure

Strong materials are used in the manufacturing of air filters intended for high pressure operation.

Specifications

Part no.	-X425
Proof pressure	3.0 MPa
Max. operating pressure	2.0 MPa
Set pressure range	0.1 to 1.6 MPa
Ambient and fluid temperature	-5 to 60°C (With no freezing)

Applicable Model

Model	AW20	AW30	AW40	AW40-06
Port size	1/8, 1/4	1/4, 3/8	1/4, 3/8, 1/2	3/4



How to Order

AW 30 - F 03 BG - 2 N - X430

Filter regulator

Body size: 30 40

Thread type: Nil Rc, N (1) NPT, F (2) G

Port size: Symbol Port size Body size
02 1/4 ● ●
03 3/8 ● ●
04 1/2 — ●
06 3/4 — ●

Option (3): Symbol Description Applicable model
Nil — —
B With bracket AW30/40
G (4) With round pressure gauge (With limit indicator) AW30/40
H With set nut (For panel mount) AW30/40

Bowl: Symbol Description Applicable model
Nil (5) Metal bowl AW30/40

Option: Symbol Description Applicable model
1 (6) 0.02 to 0.2 MPa setting AW30/40
J (7) Drain guide 1/4 AW30/40
N Non-relieving type AW30/40
R Flow direction: Right → Left AW30/40
z (8) Name plate, caution plate for bowl, and pressure gauge in imperial units (PSI, °F) AW30/40

* When more than one specification is required, indicate in ascending alphanumeric order.
 Note 6) The only difference from the standard specifications is the adjusting spring for the regulator. It does not restrict the setting of 0.2 MPa or more.
 Note 7) Without a valve function.
 Note 8) For thread type NPT. This product is for overseas use only according to the new Measurement Law. (The SI unit type is provided for use in Japan.)

Note 9) Please consult with SMC for detailed dimensions and available attachments and options.
 Note 10) Comes with type T handle.

How to Order

AW 30 - F 03 BG - 2 N - X425

Filter regulator

Body size: 20 30 40

Thread type: Nil Rc, N (1) NPT, F (2) G

Port size: Symbol Port size Body size
01 1/8 ● — —
02 1/4 — ● ●
03 3/8 — ● ●
04 1/2 — — ●
06 3/4 — — ●

Option (3): Symbol Description Applicable model
Nil — —
B With bracket AW20/40
G (4) With round pressure gauge (With limit indicator) AW20/40
H With set nut (For panel mount) AW20/40

Bowl: Symbol Description Applicable model
2 (5) Metal bowl AW20 to 40
8 (5) Metal bowl with level gauge AW30/40

Optional specifications: Symbol Description Applicable model
J (6) Drain guide 1/4 AW30/40
N Non-relieving type AW20 to 40
R Flow direction: Right → Left AW20 to 40
z (7) Name plate, caution plate for bowl, and pressure gauge in imperial units (PSI, °F) AW20 to 40

* When more than one specification is required, indicate in ascending alphanumeric order.
 Note 6) Without a valve function.
 Note 7) For thread type NPT.
 This product is for overseas use only according to the new Measurement Law. (The SI unit type is provided for use in Japan.)



Safety Instructions

These safety instructions are intended to prevent a hazardous situation and/or equipment damage. These instructions indicate the level of potential hazard by labels of "Caution", "Warning" or "Danger". To ensure safety, be sure to observe ISO 4414 ^{Note 1)}, JIS B 8370 ^{Note 2)} and other safety practices.

 **Caution** : Operator error could result in injury or equipment damage.

 **Warning** : Operator error could result in serious injury or loss of life.

 **Danger** : In extreme conditions, there is a possible result of serious injury or loss of life.

Note 1) ISO 4414: Pneumatic fluid power--General rules relating to systems.

Note 2) JIS B 8370: General Rules for Pneumatic Equipment

Warning

1. The compatibility of pneumatic equipment is the responsibility of the person who designs the pneumatic system or decides its specifications.

Since the products specified here are used in various operating conditions, their compatibility for the specific pneumatic system must be based on specifications or after analysis and/or tests to meet your specific requirements. The expected performance and safety assurance will be the responsibility of the person who has determined the compatibility of the system. This person should continuously review the suitability of all items specified, referring to the latest catalog information with a view to giving due consideration to any possibility of equipment failure when configuring a system.

2. Only trained personnel should operate pneumatically operated machinery and equipment.

Compressed air can be dangerous if an operator is unfamiliar with it. Assembly, handling or repair of pneumatic systems should be performed by trained and experienced operators.

3. Do not service machinery/equipment or attempt to remove components until safety is confirmed.

1. Inspection and maintenance of machinery/equipment should only be performed once measures to prevent falling or runaway of the driver objects have been confirmed.
2. When equipment is to be removed, confirm the safety process as mentioned above. Cut the supply pressure for this equipment and exhaust all residual compressed air in the system.
3. Before machinery/equipment is restarted, take measures to prevent shooting-out of cylinder piston rod, etc.

4. Contact SMC if the product is to be used in any of the following conditions:

1. Conditions and environments beyond the given specifications, or if product is used outdoors.
2. Installation on equipment in conjunction with atomic energy, railway, air navigation, vehicles, medical equipment, food and beverages, recreation equipment, emergency stop circuits, clutch and brake circuits in press applications, or safety equipment.
3. An application which has the possibility of having negative effects on people, property, or animals, requiring special safety analysis.



Common Precautions

Be sure to read before handling.

For detailed precautions on every series, refer to main text.

Selection

Warning

1. Confirm the specifications.

Products represented in this catalog are designed for use in compressed air applications only (including vacuum), unless otherwise indicated.

Do not use the product outside their design parameters.

Please contact SMC when using the products in applications other than compressed air (including vacuum).

Mounting

Warning

1. Instruction manual

Install the products and operate them only after reading the instruction manual carefully and understanding its contents. Also keep the manual where it can be referred to as necessary.

2. Securing the space for maintenance

When installing the products, please allow access for maintenance.

3. Tightening torque

When installing the products, please follow the listed torque specifications.

Piping

Caution

1. Before piping

Make sure that all debris, cutting oil, dust, etc., are removed from the piping.

2. Wrapping of pipe tape

When screwing piping or fittings into ports, ensure that chips from the pipe threads or sealing material do not get inside the piping. Also, when the pipe tape is used, leave 1.5 to 2 thread ridges exposed at the end of the threads.

Air Supply

Warning

1. Operating fluid

Please consult with SMC when using the product in applications other than compressed air (including vacuum).

Regarding products for general fluid, please ask SMC about applicable fluids.

2. Install an air dryer, aftercooler, etc.

Excessive condensate in a compressed air system may cause valves and other pneumatic equipment to malfunction.

Installation of an air dryer, after cooler etc. is recommended.

3. Drain flushing

If condensate in the drain bowl is not emptied on a regular basis, the bowl will over flow and allow the condensate to enter the compressed air lines.

If the drain bowl is difficult to check and remove, it is recommended that a drain bowl with the auto-drain option be installed.

For compressed air quality, refer to "Air Preparation Equipment" catalog.

4. Use clean air

If the compressed air supply is contaminated with chemicals, synthetic materials, corrosive gas, etc., it may lead to break down or malfunction.

Operating Environment

Warning

1. Do not use in environments where the product is directly exposed to corrosive gases, chemicals, salt water, water or steam.

2. Do not expose the product to direct sunlight for an extended period of time.

3. Do not use in a place subject to heavy vibrations and/or shocks.

4. Do not mount the product in locations where it is exposed to radiant heat.

Maintenance

Warning

1. Maintenance procedures are outlined in the operation manual.

Not following proper procedures could cause the product to malfunction and could lead to damage to the equipment or machine.

2. Maintenance work

If handled improperly, compressed air can be dangerous.

Assembly, handling and repair of pneumatic systems should be performed by qualified personnel only.

3. Drain flushing

Remove drainage from air filters regularly. (Refer to the specifications.)

4. Shut-down before maintenance

Before attempting any kind of maintenance make sure the supply pressure is shut of and all residual air pressure is released from the system to be worked on.

5. Start-up after maintenance and inspection

Apply operating pressure and power to the equipment and check for proper operation and possible air leaks. If operation is abnormal, please verify product set-up parameters.

6. Do not make any modifications to be product.

Do not take the product apart.

Quality Assurance Information (ISO 9001, ISO 14001)

Reliable quality of products in the global market

To enable our customers throughout the world to use our products with even greater confidence, SMC has obtained certification for international standards “ISO 9001” and “ISO 14001”, and created a complete structure for quality assurance and environmental controls. SMC products pursue to meet its customers’ expectations while also considering company’s contribution in society.

Quality management system ISO 9001

This is an international standard for quality control and quality assurance. SMC has obtained a large number of certifications in Japan and overseas, providing assurance to our customers throughout the world.



Environmental management system ISO 14001

This is an international standard related to environmental management systems and environmental inspections. While promoting environmentally friendly automation technology, SMC is also making diligent efforts to preserve the environment.



SMC’s quality control system



Quality policies

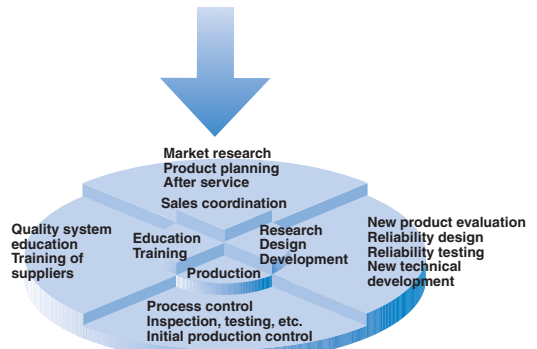

Quality control activities

SMC Product Conforming to Inter

SMC products complying with EN/ISO, CSA/UL standards are supporting



The CE mark indicates that machines and components meet essential requirements of all the EC Directives applied.

It has been obligatory to apply CE marks indicating conformity with EC Directives when machines and components are exported to the member Nations of the EU.

Once “A manufacturer himself” declares a product to be safe by means of CE marking (declaration of conformity by manufacturer), free distribution inside the member Nations of the EU is permissible.

■ CE Mark

SMC provides CE marking to products to which EMC and Low Voltage Directives have been applied, in accordance with CETOP (European hydraulics and pneumatics committee) guide lines.

■ As of February 1998, the following 18 countries will be obliged to conform to CE mark legislation

Iceland, Ireland, United Kingdom, Italy, Austria, Netherlands, Greece, Liechtenstein, Sweden, Spain, Denmark, Germany, Norway, Finland, France, Belgium, Portugal, Luxembourg

■ EC Directives and Pneumatic Components

• Machinery Directive

The Machinery Directive contains essential health and safety requirements for machinery, as applied to industrial machines e.g. machine tools, injection molding machines and automatic machines. Pneumatic equipment is not specified in Machinery Directive. However, the use of SMC products that are certified as conforming to EN Standards, allows customers to simplify preparation work of the Technical Construction File required for a Declaration of Conformity.

• Electromagnetic Compatibility (EMC) Directive

The EMC Directive specifies electromagnetic compatibility. Equipment which may generate electromagnetic interference or whose function may be compromised by electromagnetic interference is required to be immune to electromagnetic affects (EMS/immunity) without emitting excessive electromagnetic affects (EMI/emission).

• Low Voltage Directive

This directive is applied to products, which operate above 50 VAC to 1000 VAC and 75 VDC to 1500 VDC operating voltage, and require electrical safety measures to be introduced.

• Simple Pressure Vessels Directive

This directive is applied to welded vessels whose maximum operating pressure (PS) and volume of vessel (V) exceed 50 bar/L. Such vessels require EC type examination and then CE marking.

national Standards

you to comply with EC directives and CSA/UL standards.



■ CSA Standards & UL Standards

UL and CSA standards have been applied in North America (U.S.A. and Canada) symbolizing safety of electric products, and are defined to mainly prevent danger from electric shock or fire, resulting from trouble with electric products. Both UL and CSA standards are acknowledged in North America as the first class certifying body. They have a long experience and ability for issuing product safety certificate. Products approved by CSA or UL standards are accepted in most states and governments beyond question.

Since CSA is a test certifying body as the National Recognized Testing Laboratory (NRTL) within the jurisdiction of Occupational Safety and Health Administration (OSHA), SMC was tested for compliance with CSA Standards and UL Standards at the same time and was approved for compliance with the two Standards. The above CSA NRTL/C logo is described on a product label in order to indicate that the product is approved by CSA and UL Standards.

■ TSSA (MCCR) Registration Products

TSSA is the regulation in Ontario State, Canada. The products that the operating pressure is more than 5 psi (0.03 MPa) and the piping size is bigger than 1 inch. fall into the scope of TSSA regulation.

Products conforming to CE Standard



With CE symbol for simple visual recognition

In this catalog each accredited product series is indicated with a CE mark symbol. However, in some cases, every available models may not meet CE compliance. Please visit our web site for the latest selection of available models with CE mark.

<http://www.smcworld.com>

SMC's Global Service Network

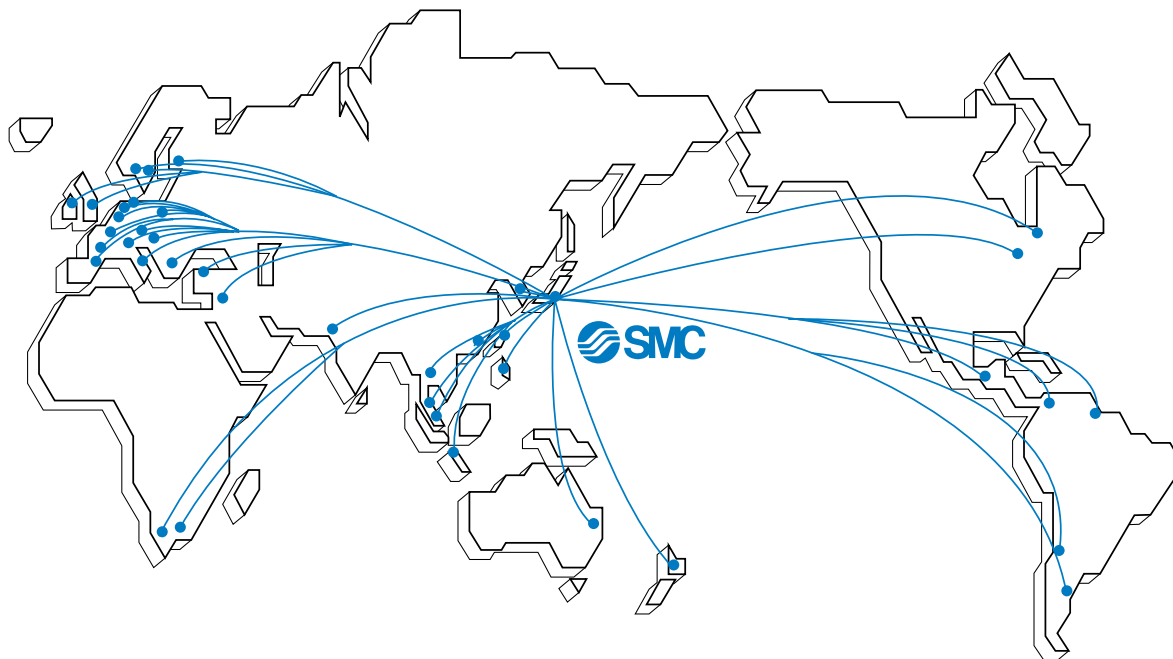

America

U.S.A. **SMC Corporation of America**

3011 North Franklin Road Indianapolis, IN 46226, U.S.A.
TEL: 317-899-4440 FAX: 317-899-3102

CANADA **SMC Pneumatics (Canada) Ltd.**

6768 Financial Drive Mississauga, Ontario, L5N 7J6 Canada
TEL: 905-812-0400 FAX: 905-812-8686

MEXICO **SMC Corporation (Mexico), S.A. DE C.V.**

Carr. Silao-Trejo K.M. 2.5 S/N, Predio San Jose del Duranzo
C.P. 36100, Silao, Gto., Mexico
TEL: 472-72-2-55-00 FAX: 472-72-2-59-44/2-59-46

CHILE **SMC Pneumatics (Chile) S.A.**

Av. La Montaña 1,115 km. 16.5 P. Norte Parque
Industrial Valle Grande, Lampa Santiago, Chile
TEL: 02-270-8600 FAX: 02-270-8601

ARGENTINA **SMC Argentina S.A.**

Teodoro Garcia 3860 (1427) Buenos Aires, Argentina
TEL: 011-4555-5762 FAX: 011-4555-5762

BOLIVIA **SMC Pneumatics Bolivia S.R.L.**

Avenida Beni Numero 4665
Santa Cruz de la Sierra-Casilla de Correo 2281, Bolivia
TEL: 591-3-3428383 FAX: 591-3-3449900

VENEZUELA **SMC Neumatica Venezuela S.A.**

Apartado 40152, Avenida Nueva Granada, Edificio Wanlac,
Local 5, Caracas 1040-A, Venezuela
TEL: 2-632-1310 FAX: 2-632-3871

PERU (Distributor) **IMPECO Automatizacion Industrial S.A.**

AV. Canevaro 752, Lince, Lima, Peru
TEL: 1-471-6002 FAX: 1-471-0935

URUGUAY (Distributor) **BAKO S.A.**

Galicia 1650 esq. Gaboto C.P. 11200, Montevideo, Uruguay
TEL: 2-401-6603 FAX: 2-409-4306

BRAZIL **SMC Pneumaticos Do Brasil Ltda.**

Rua. Dra. Maria Fidelis, nr. 130, Jardim Piraporinha-Diadema-S.P.
CEP: 09950-350, Brasil
TEL: 11-4051-1177 FAX: 11-4071-6636

COLOMBIA (Distributor) **Airmatic Ltda.**

Calle 18 69-05 Apart. Aereo 081045 Santa Fe de Bogotá, Colombia
TEL: 1-424-9240 FAX: 1-424-9260

Europe

U.K. **SMC Pneumatics (U.K.) Ltd.**

Vincent Avenue, Crownhill, Milton Keynes, MK8 0AN, Buckinghamshire, U.K.
TEL: 01908-563888 FAX: 01908-561185

GERMANY **SMC Pneumatik GmbH**

Boschring 13-15 D-63329 Egelsbach, Germany
TEL: 06103-4020 FAX: 06103-402139

ITALY **SMC Italia S.p.A.**

Via Garibaldi 62 I-20061 Carugate Milano, Italy
TEL: 02-9271365 FAX: 02-9271365

FRANCE **SMC Pneumatique S.A.**

1 Boulevard de Strasbourg, Parc Gustave Eiffel, Bussy Saint Georges, F-77600
Marne La Vallee Cedex 3 France
TEL: 01-64-76-10-00 FAX: 01-64-76-10-10

SWEDEN **SMC Pneumatics Sweden AB**

Ekhagsvägen 29-31, S-141 05 Huddinge, Sweden
TEL: 08-603-07-00 FAX: 08-603-07-10

SWITZERLAND **SMC Pneumatik AG**

Dorfstrasse 7, Postfach 117, CH-8484 Weisslingen, Switzerland
TEL: 052-396-3131 FAX: 052-396-3191

AUSTRIA **SMC Pneumatik GmbH (Austria)**

Girakstrasse 8, A-2100 Korneuburg, Austria
TEL: 0-2262-6228-0 FAX: 0-2262-62285

SPAIN **SMC España, S.A.**

Zuazobidea 14 Pol. Ind. Júndiz 01015 Vitoria, Spain
TEL: 945-184-100 FAX: 945-184-510

IRELAND **SMC Pneumatics (Ireland) Ltd.**

2002 Citywest Business Campus, Naas Road, Saggart, Co. Dublin, Ireland
TEL: 01-403-9000 FAX: 01-466-0385

NETHERLANDS (Associated company) **SMC Pneumatics BV**

De Ruyterkade 120, NL-1011 AB Amsterdam, Netherlands
TEL: 020-5318888 FAX: 020-5318880

GREECE (Distributor) **S.Parianopoulos S.A.**

7, Konstantinoupoleos Street 11855 Athens, Greece
TEL: 01-3426076 FAX: 01-3455578

DENMARK **SMC Pneumatik A/S**

Knudsminde 4 B DK-8300
Odder, Denmark
TEL: 70252900 FAX: 70252901

Europe

FINLAND SMC Pneumatics Finland OY

PL72, Tiistiniityntie 4, SF-02231 ESP00, Finland
TEL: 09-8595-80 FAX: 09-8595-8595

NORWAY SMC Pneumatics Norway A/S

Vollsvæien 13C, Granfoss Næringspark N-1366 LYSAKER, Norway
TEL: 67-12-90-20 FAX: 67-12-90-21

BELGIUM (Distributor) SMC Pneumatics N.V./S.A.

Nijverheidsstraat 20 B-2160 Wommelgem Belgium
TEL: 03-355-1464 FAX: 03-355-1466

POLAND SMC Industrial Automation Polska Sp.z.o.o.

ul. Konstruktorska 11A, PL-02-673 Warszawa, Poland
TEL: 022-548-5085 FAX: 022-548-5087

TURKEY (Distributor) Entek Pnömatik San.ve Tic. Ltd. Sti

Perpa Tic. Merkezi Kat:11 No.1625 80270 Okmeydani Istanbul, Türkiye
TEL: 0212-221-1512 FAX: 0212-221-1519

RUSSIA SMC Pneumatik LLC.

36/40 Sredny prospect V.O. St. Petersburg 199004, Russia
TEL: 812-118-5445 FAX: 812-118-5449

CZECH SMC Industrial Automation CZ s.r.o.

Hudcova 78a, CZ-61200 Brno, Czech Republic
TEL: 05-4121-8034 FAX: 05-4121-8034

HUNGARY SMC Hungary Ipari Automatizálási kft.

Budafoki ut 107-113 1117 Budapest
TEL: 01-371-1343 FAX: 01-371-1344

ROMANIA SMC Romania S.r.l.

Str. Frunzei, Nr. 29, Sector 2, Bucharest, Romania
TEL: 01-3205111 FAX: 01-3261489

SLOVAKIA SMC Priemyselná automatizácia, s.r.o.

Nova 3, SK-83103 Bratislava
TEL: 02-4445-6725 FAX: 02-4445-6028

SLOVENIA SMC Industrijska Avtomatila d.o.o.

Grajski trg 15, SLO- 8360 Zuzemberk, Slovenia
TEL: 07388-5240 FAX: 07388-5249

LATVIA SMC Pneumatics Latvia SIA

Šmerļa ielā 1-705, Rīga LV-1006
TEL: 777 94 74 FAX: 777 94 75

SOUTH AFRICA (Distributor) Hyflo Southern Africa (Pty.) Ltd.

P.O.Box 240 Paardeneiland 7420 South Africa
TEL: 021-511-7021 FAX: 021-511-4456

EGYPT (Distributor) Saadani Trading & Ind. Services

15 Sebaai Street, Miami 21411 Alexandria, Egypt
TEL: 3-548-50-34 FAX: 3-548-50-34

Oceania/Asia

AUSTRALIA SMC Pneumatics (Australia) Pty.Ltd.

14-18 Hudson Avenue Castle Hill NSW 2154, Australia
TEL: 02-9354-8222 FAX: 02-9894-5719

NEW ZEALAND SMC Pneumatics (New Zealand) Ltd.

8C Sylvia Park Road Mt.Wellington Auckland, New Zealand
TEL: 09-573-7007 FAX: 09-573-7002

TAIWAN SMC Pneumatics (Taiwan) Co.,Ltd.

17, Lane 205, Nansan Rd., Sec.2, Luzhu-Hsiang, Taoyuan-Hsien, TAIWAN
TEL: 03-322-3443 FAX: 03-322-3387

HONG KONG SMC Pneumatics (Hong Kong) Ltd.

29/F, Clifford Centre, 778-784 Cheung, Sha Wan Road, Lai Chi Kok, Kowloon, Hong Kong
TEL: 2744-0121 FAX: 2785-1314

SINGAPORE SMC Pneumatics (S.E.A.) Pte. Ltd.

89 Tuas Avenue 1, Jurong Singapore 639520
TEL: 6861-0888 FAX: 6861-1889

PHILIPPINES SHOKETSU SMC Corporation

Unit 201 Common Goal Tower, Madrigal Business Park, Ayala Alabang Muntinlupa, Philippines
TEL: 02-8090565 FAX: 02-8090586

MALAYSIA SMC Pneumatics (S.E.A.) Sdn. Bhd.

Lot 36 Jalan Delima1/1, Subang Hi-Tech Industrial Park, Batu 3 40000 Shah Alam Selangor, Malaysia
TEL: 03-56350590 FAX: 03-56350602

SOUTH KOREA SMC Pneumatics Korea Co., Ltd.

Woolim e-BIZ Center (Room 1008), 170-5, Guro-Dong, Guro-Gu, Seoul, 152-050, South Korea
TEL: 02-3219-0700 FAX: 02-3219-0702

CHINA SMC (China) Co., Ltd.

7 Wan Yuan St. Beijing Economic & Technological Development Zone 100176, China
TEL: 010-67882111 FAX: 010-67881837

THAILAND SMC Thailand Ltd.

134/6 Moo 5, Tiwanon Road, Bangkadi, Amphur Muang, Patumthani 12000, Thailand
TEL: 02-963-7099 FAX: 02-501-2937

INDIA SMC Pneumatics (India) Pvt. Ltd.

D-107 to 112, Phase-2, Extension, Noida, Dist. Gautaim Budh Nagar, U.P. 201 305, India
TEL: (0120)-4568730 FAX: 0120-4568933

INDONESIA (Distributor) P.T. Riyadi Putera Makmur

Jalan Hayam Wuruk Komplek Glodok Jaya No. 27-28 Jakarta 11180 Indonesia
TEL: 021-625 5548 FAX: 021-625 5888

PAKISTAN (Distributor) Jubilee Corporation

First Floor Mercantile Centre, Newton Road Near Boulton Market P.O. Box 6165 Karachi 74000 Pakistan
TEL: 021-243-9070/8449 FAX: 021-241-4589

ISRAEL (Distributor) Baccara Automation Control

Kvutza Geva 18915 Israel
TEL: 04-653-5960 FAX: 04-653-1445

SAUDI ARABIA (Distributor) Assaggaff Trading Est.

P.O. Box 3385 Al-Amir Majed Street, Jeddah-21471, Saudi Arabia
TEL: 02-6761574 FAX: 02-6708173