

SD6050

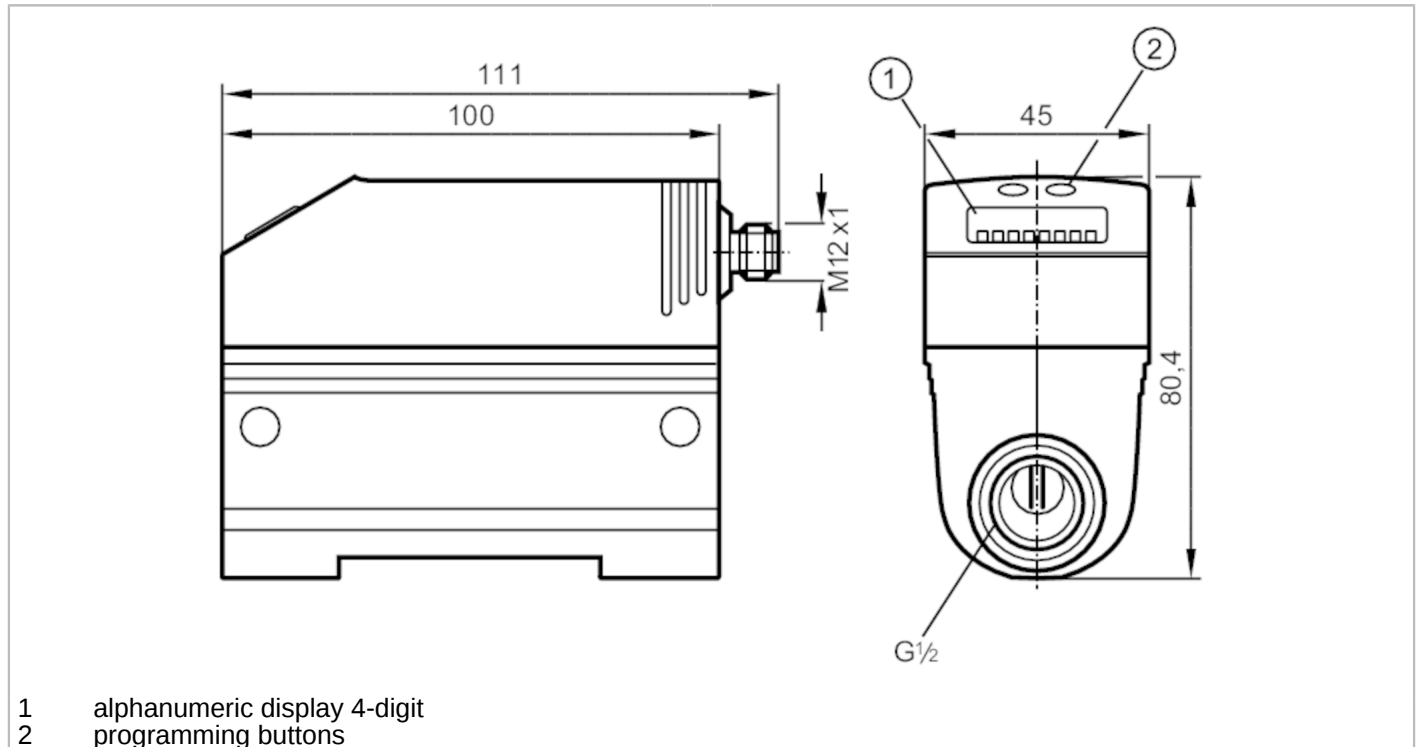

Compressed air meter

SDR12DGXFPKG/US-100



- 1 alphanumeric display 4-digit
- 2 programming buttons



Product characteristics

Number of inputs and outputs	Number of digital outputs: 2; Number of analogue outputs: 1		
Measuring range	10...1250 l/min	0.3...103.6 m/s	0.2...75 m³/h
Process connection	threaded connection G 1/2 DN15		

Application

Application	for industrial applications
Media	compressed air
Medium temperature [°C]	0...60
Pressure rating [bar]	16

Electrical data

Operating voltage [V]	18...30 DC; (according to EN 50178 SELV/PELV)
Current consumption [mA]	< 110
Protection class	III
Reverse polarity protection	yes
Power-on delay time [s]	1

Inputs / outputs

Number of inputs and outputs	Number of digital outputs: 2; Number of analogue outputs: 1
------------------------------	---



Compressed air meter

SDR12DGXFPKG/US-100

Outputs			
Total number of outputs		2	
Output signal		switching signal; analogue signal; pulse signal; IO-Link; (configurable)	
Electrical design		PNP	
Number of digital outputs		2	
Output function		normally open / normally closed; (parameterisable)	
Max. voltage drop switching output DC	[V]	2	
Permanent current rating of switching output DC	[mA]	250; (per output)	
Number of analogue outputs		1	
Analogue current output	[mA]	4...20; (scalable)	
Max. load	[Ω]	500	
Pulse output		consumed quantity meter	
Short-circuit protection		yes	
Type of short-circuit protection		pulsed	
Overload protection		yes	
Measuring/setting range			
Measuring range		10...1250 l/min	0.3...103.6 m/s
Display range		0...1500 l/min	0...124.3 m/s
Set point SP		10...1250 l/min	0.8...103.6 m/s
Reset point rP		4...1244 l/min	0.3...103.1 m/s
Analogue start point ASP		0...938 l/min	0...77.7 m/s
Analogue end point AEP		312...1250 l/min	25.9...103.6 m/s
In steps of		1 l/min	0.1 m/s
Volumetric flow quantity monitoring			
Pulse value		0.001...1000000 m ³	
In steps of		0.001 m ³	
Pulse length	[s]	≥ 0,02 / ≤ 2	
Temperature monitoring			
Measuring range	[°C]	0...60	
Display range	[°C]	-12...72	
Accuracy / deviations			
Flow monitoring			
Repeatability	[% of the measured value]	± 1,5	
Accuracy (in the measuring range)		± (15 % MW + 1,5 % MEW); (maximum value to be achieved for air quality class 344 (DIN 8573-1); when using pipes of tolerance class T3/T4; inlet and outlet pipe lengths without edges and abrupt diameter changes; inner surface of the pipe free of burrs)	
Temperature monitoring			
Accuracy	[K]	± 2; (medium flow in the limit area of the flow measurement range)	

SD6050



Compressed air meter

SDR12DGXFPKG/US-100

Response times		
Flow monitoring		
Response time [s]	0.1; (dAP = 0)	
Damping for the switching output dAP in steps [s]	0 - 0,2 - 0,4 - 0,6 - 0,8 - 1	
Software / programming		
Parameter setting options	Flow monitoring; quantity meter; Preset counter; Temperature monitoring; hysteresis / window; normally open / normally closed; current/pulse output; display can be rotated and switched off; Display unit; totaliser	
Interfaces		
Communication interface	IO-Link	
Transmission type	COM2 (38,4 kBaud)	
IO-Link revision	1.1	
SDCI standard	IEC 61131-9 CDV	
IO-Link device ID	262 d / 00 01 06 h	
Profiles	no profile	
SIO mode	yes	
Required master port type	A	
Process data analogue	3	
Process data binary	2	
Min. process cycle time [ms]	4.1	
Operating conditions		
Ambient temperature [°C]	0...60	
Storage temperature [°C]	-20...85	
Max. relative air humidity [%]	90	
Protection	IP 65	
Tests / approvals		
EMC	DIN EN 61000-6-2	
	DIN EN 61000-6-3	
Vibration resistance	DIN EN 68000-2-6	5 g (55...2000 Hz)
MTTF [years]	227	
Pressure Equipment Directive	Sound engineering practice; can be used for group 2 fluids; group 1 fluids on request	
Mechanical data		
Weight [g]	579	
Materials	PBT-GF20; NBR; PC; stainless steel (1.4301 / 304); PTFE; brass coated; FKM; aluminium powder-coated	
Materials (wetted parts)	stainless steel (1.4301 / 304); FKM; ceramics glass passivated; PEEK GF30; polyester; aluminium	
Tightening torque [Nm]	50	
Process connection	threaded connection G 1/2 DN15	

SD6050



Compressed air meter

SDR12DGXFPKG/US-100

Displays / operating elements		
Display	Display unit	5 x LED, green (NI/min, Nm ³ /h, Nm/s, Nm ³ , °C)
	function display	1 x LED, green
	switching status	2 x LED, yellow
	measured values	alphanumeric display, 4-digit
	programming	alphanumeric display, 4-digit
Remarks		
Remarks	MW = measured value	
	MEW = Final value of the measuring range	
	Measuring, display and setting ranges refer to the standard volume flow according to DIN ISO 2533.	
	For information about installation and operation please see the operating instructions.	
Pack quantity	1 pcs.	

Electrical connection

Connector: 1 x M12



Connection

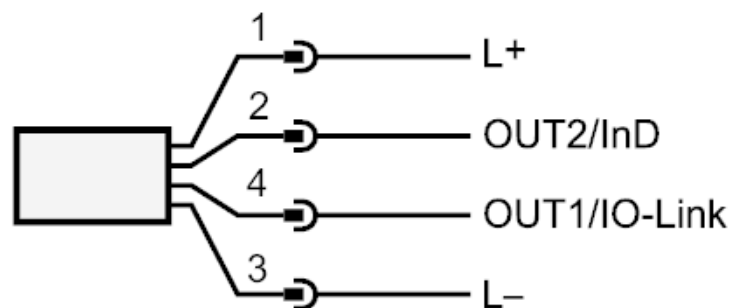

OUT1/IO-Link: switching output volumetric flow quantity monitoring
Pulse output quantity meter
signal output Preset counter

OUT2/InD: switching output volumetric flow quantity monitoring / Temperature monitoring
analogue output volumetric flow quantity monitoring / Temperature monitoring
input counter reset