

Part no.: 53800134
BT840M
Mounting bracket

Figure can vary

Contents

- Technical data
- Dimensioned drawings

Part no.: 53800134 – BT840M – Mounting bracket

Technical data

Basic data

Application	Mounting on chamfered 90° corner
Suitable for	RSL 400 safety laser scanner

Mechanical data

Dimension (W x H x L)	84.9 mm x 72 mm x 205.2 mm
Net weight	1,080 g
Housing color	Yellow, RAL 1021
Type of fastening, at system	Through-hole mounting
Type of fastening, at device	Screw type
Mounting device material	Metal

Classification

Customs tariff number	73182900
eCl@ss 8.0	27279202
eCl@ss 9.0	27273701
ETIM 5.0	EC003015
ETIM 6.0	EC003015

Dimensioned drawings

All dimensions in millimeters

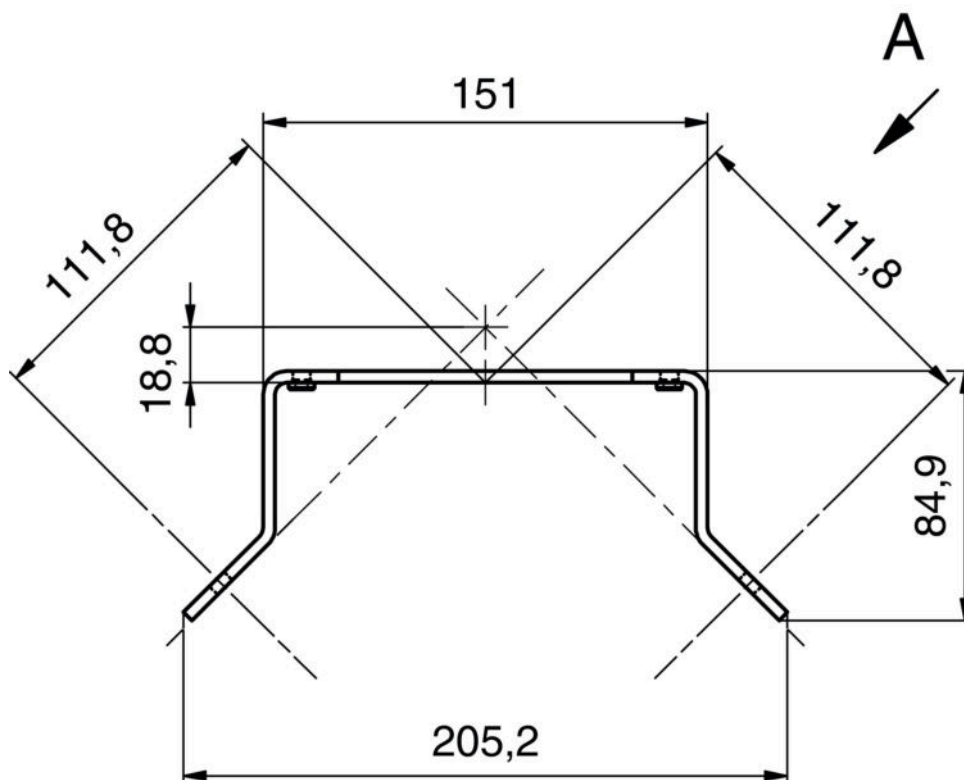

View A

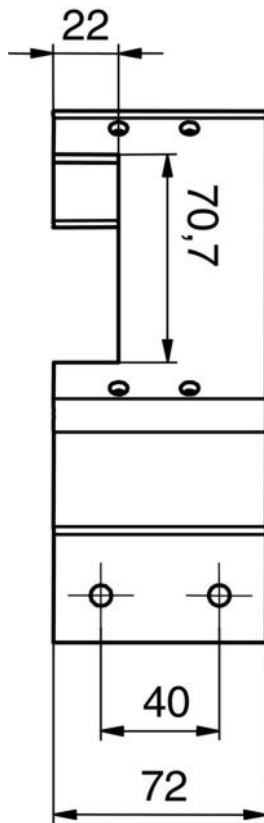

Example: mounting on a chamfered corner

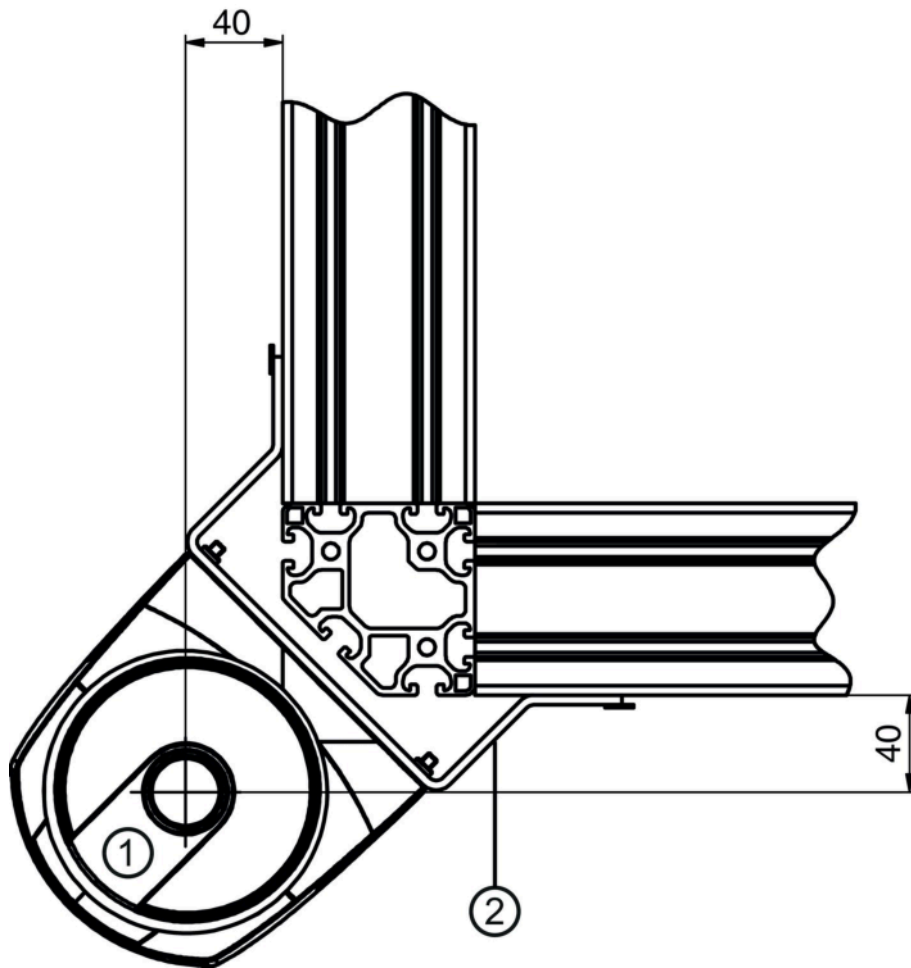

- 1 Safety sensor
- 2 BT840M mounting bracket