

BUSBAR ADAPTER SYSTEM BUSBAR ADAPTER
 72MM WIDE 60MM SYSTEM, 5+10MM RAIL WIDTH
 ADAPTER LENGTH 182MM FOR ASSEMBLING WITH
 CIRCUIT BREAKER SIRIUS 3R MODULE S3 (100A)
 APPLIC. RANGE 480 - 690V

Model

product brand name

SENTRON

General Product Approval

Declaration of
 Conformity

Test
 Certificates



CSA



GOST



UR



EG-Konf.

[Special Test
 Certificate](#)

Shipping Approval

other



GL



PRS



RINA

[other](#)

Further information

Information- and Downloadcenter (Catalogs, Brochures,...)

<http://www.siemens.com/lowvoltage/catalogs>

Industry Mall (Online ordering system)

<https://eb.automation.siemens.com/mall/en/WW/Catalog/Product/8US12114TM00>

Service&Support (Manuals, Certificates, Characteristics, FAQs,...)

<http://support.automation.siemens.com/WW/view/en/8US12114TM00/all>

Image database (product images, 2D dimension drawings, 3D models, device circuit diagrams, ...)

http://www.automation.siemens.com/bilddb/cax_en.aspx?mlfb=8US12114TM00

CAX-Online-Generator

<http://www.siemens.com/cax>

Tender specifications

<http://ausschreibungstexte.siemens.com/tiplv>

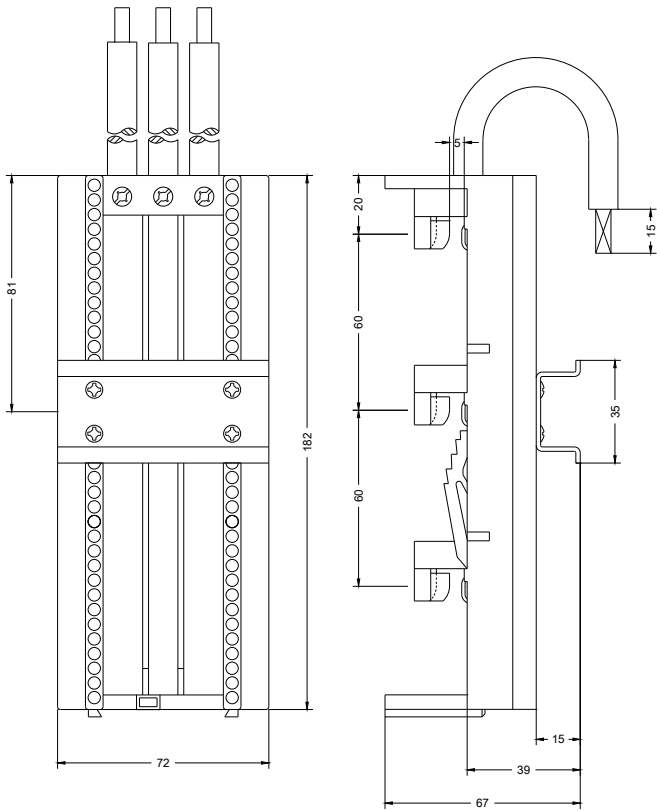

last modified:

11.03.2015