

# PRODUKTDATENBLATT

## POLO-KAL NG Abzweig 75/50/87

Artikel-Nr. 02220

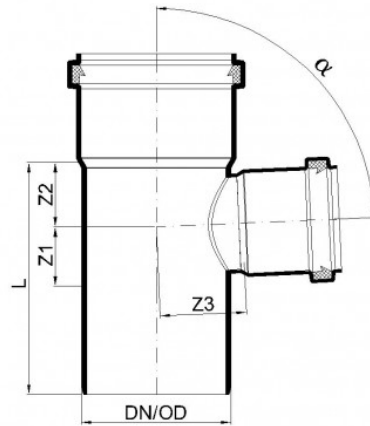
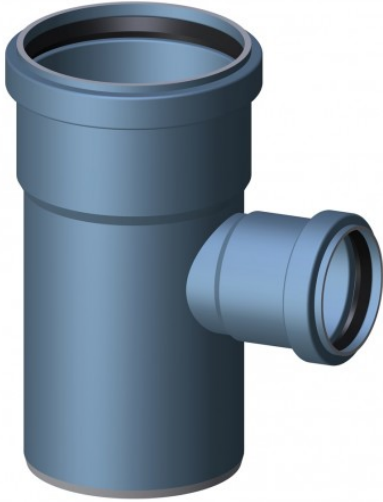

PURE  
PROGRESS / poloplast

### Technische Daten

DN/OD	75
DN/OD2	50
Winkel $\alpha$	87,5°
Länge L	117 mm
Z1	30 mm
Z2	32 mm
Z3	43 mm
Gewicht	0,18 kg/Stk.
Verpackungseinheit	10 Stk.