

Triple-Strand Sprockets DRS with Hub, ISO 08 B-3

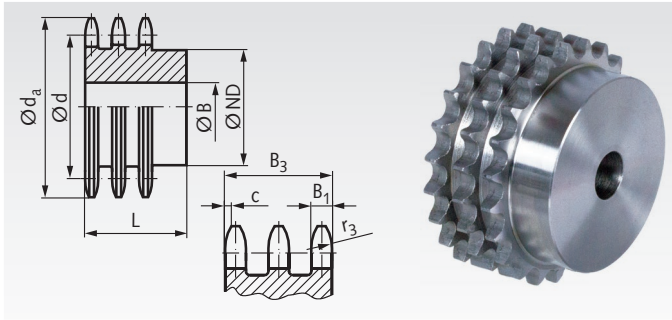

Material: Steel C45, not hardened.
Pre-bored.
Sprockets marked with * are made from grey cast iron GG25.

Ordering Details: e.g.: Product No. 13510800, DRS, ISO 08 B-3, 8 Teeth

ISO 08 B-3, Pitch 1/2 x 5/16"

$B_1 = 7 \text{ mm}$, $B_3 = 34.9 \text{ mm}$, $c = 1.3 \text{ mm}$, $r_3 = 13 \text{ mm}$

Product No.	Number of teeth	d_a mm	d mm	ND mm	B mm	L mm	Weight kg
135 108 00	8	38,0	33,18	20	10	46	0,13
135 110 00	10	45,9	41,10	28	12	46	0,24
135 111 00	11	49,9	45,07	32	16	50	0,31
135 112 00	12	53,9	49,07	35	16	50	0,39
135 113 00	13	57,9	53,07	38	16	50	0,49
135 114 00	14	61,9	57,07	42	16	50	0,60
135 115 00	15	65,9	61,09	46	16	50	0,72
135 116 00	16	69,9	65,10	50	16	50	0,85
135 117 00	17	74,0	69,11	54	16	50	0,99
135 118 00	18	78,0	73,14	58	16	50	1,14
135 119 00	19	82,0	77,16	62	16	50	1,30
135 120 00	20	86,0	81,19	66	16	50	1,47
135 121 00	21	90,1	85,22	70	20	55	1,79
135 122 00	22	94,1	89,24	70	20	55	1,93
135 123 00	23	98,1	93,27	70	20	55	2,08
135 124 00	24	102,1	97,29	75	20	55	2,32
135 125 00	25	106,2	101,33	80	20	55	2,57
135 126 00	26	110,2	105,36	85	20	55	2,79
135 127 00	27	114,2	109,40	85	20	55	2,96
135 128 00	28	118,3	113,42	90	20	55	3,25
135 129 00	29	122,3	117,46	95	20	55	3,55
135 130 00	30	126,3	121,50	100	20	55	3,86
135 135 00	35	146,5	141,68	110	20	55	5,20
135 136 00	36	150,6	145,72	120	25	55	5,64
135 138 00	38	158,6	153,80	120	25	55	6,14
135 140 00	40	166,7	161,78	120	25	55	6,60
135 145 00*	45	188,6	182,07	100	24	60	5,85
135 157 00*	57	237,1	230,54	100	24	60	6,28
135 176 00*	76	313,9	307,33	100	24	60	8,60
135 183 00*	95	390,7	384,11	120	24	67	11,90

Triple-Strand Plate wheels DRL, ISO 08 B-3

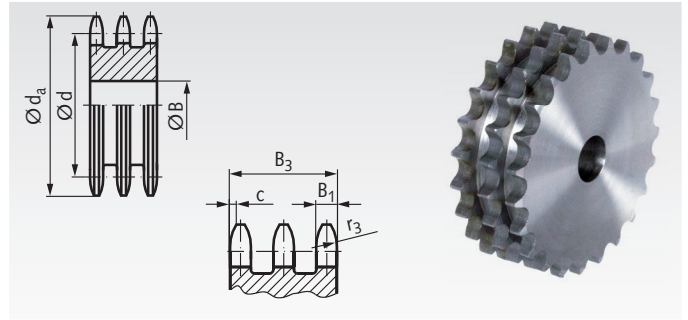

Material: Low-carbon steel, not hardable.
Pre-bored.

Ordering Details: e.g.: Product No. 13520800, DRL, ISO 08 B-3, 8 Teeth

ISO 08 B-3, Pitch 1/2 x 5/16"

$B_1 = 7 \text{ mm}$, $B_3 = 34.9 \text{ mm}$, $c = 1.3 \text{ mm}$, $r_3 = 13 \text{ mm}$

Product No.	Number of teeth	d_a mm	d mm	B mm	Weight kg
135 208 00	8	38,0	33,18	10	0,11
135 210 00	10	45,9	41,10	10	0,21
135 211 00	11	49,9	45,07	12	0,26
135 212 00	12	53,9	49,07	12	0,33
135 213 00	13	57,9	53,07	12	0,40
135 214 00	14	61,9	57,07	12	0,48
135 215 00	15	65,9	61,09	12	0,57
135 216 00	16	69,9	65,10	16	0,64
135 217 00	17	74,0	69,11	16	0,74
135 218 00	18	78,0	73,14	16	0,85
135 219 00	19	82,0	77,16	16	0,97
135 220 00	20	86,0	81,19	16	1,09
135 221 00	21	90,1	85,22	16	1,22
135 222 00	22	94,1	89,24	16	1,36
135 223 00	23	98,1	93,27	16	1,50
135 224 00	24	102,1	97,29	16	1,63
135 225 00	25	106,2	101,33	16	1,81
135 226 00	26	110,2	105,36	16	1,98
135 227 00	27	114,2	109,40	16	2,15
135 228 00	28	118,3	113,42	16	2,33
135 229 00	29	122,3	117,46	16	2,52
135 230 00	30	126,3	121,50	16	2,71
135 233 00	33	138,4	133,60	20	3,30
135 235 00	35	146,5	141,68	20	3,76
135 236 00	36	150,6	145,72	20	3,99
135 238 00	38	158,6	153,80	20	4,49
135 240 00	40	166,7	161,78	20	5,00
135 245 00	45	188,6	182,07	25	6,39
135 254 00	54	225,0	218,43	25	9,40
135 257 00	57	237,1	230,54	25	10,53
135 276 00	76	313,9	307,33	25	19,17
135 283 00	95	390,7	384,11	25	30,36

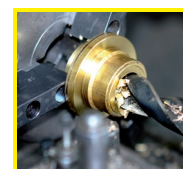

**Reworking within
24h-service possible.
Custom made parts
on request.**