

øF1 = Cable diameter without rubber bushing ø3 - ø8.5mm
 øF2 = Cable diameter with rubber bushing max. 8mm

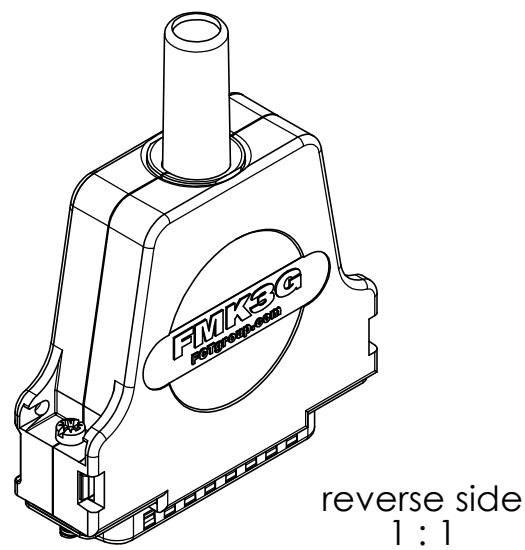
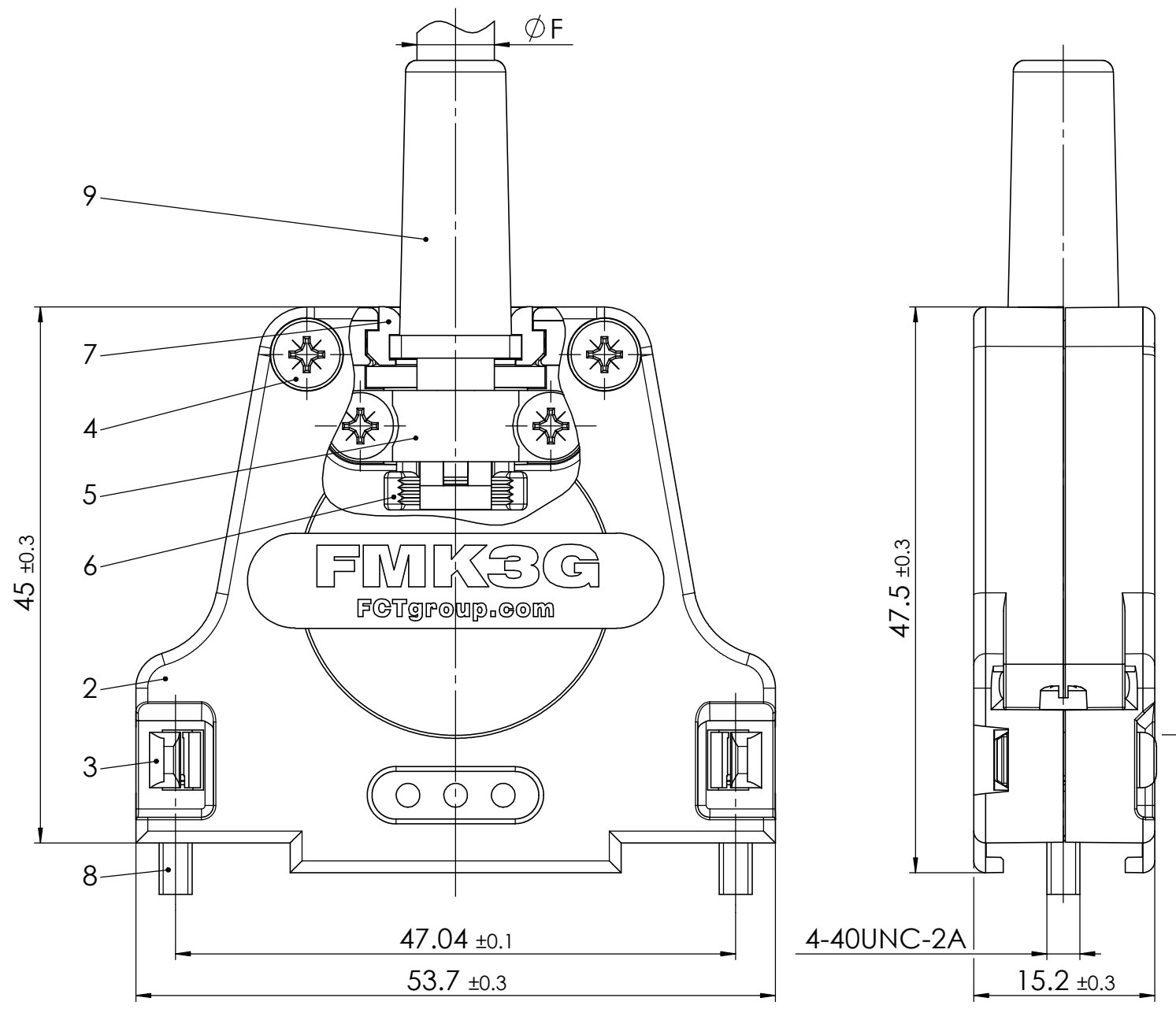
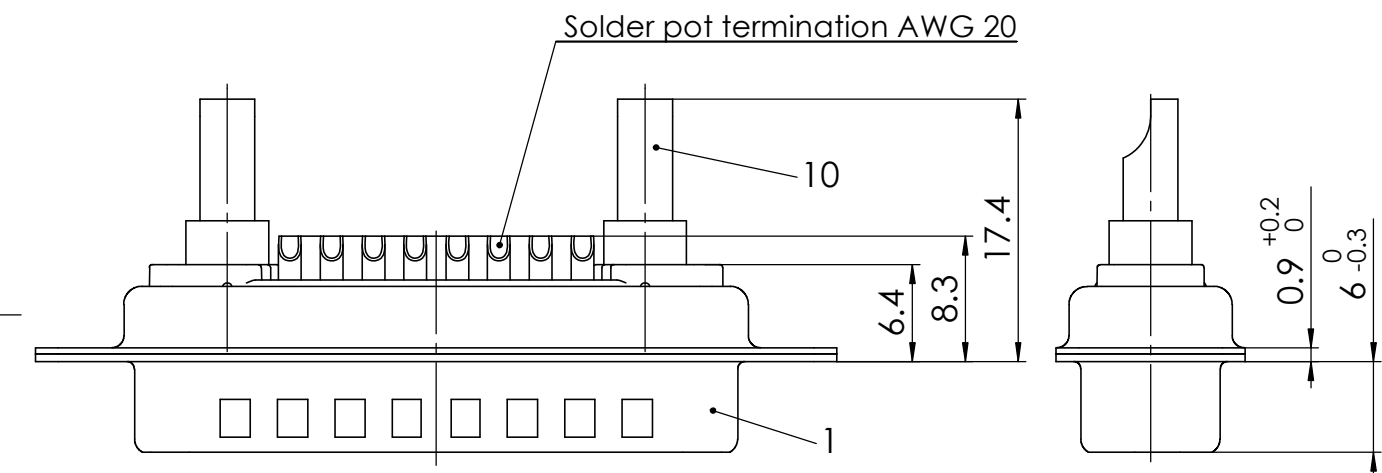
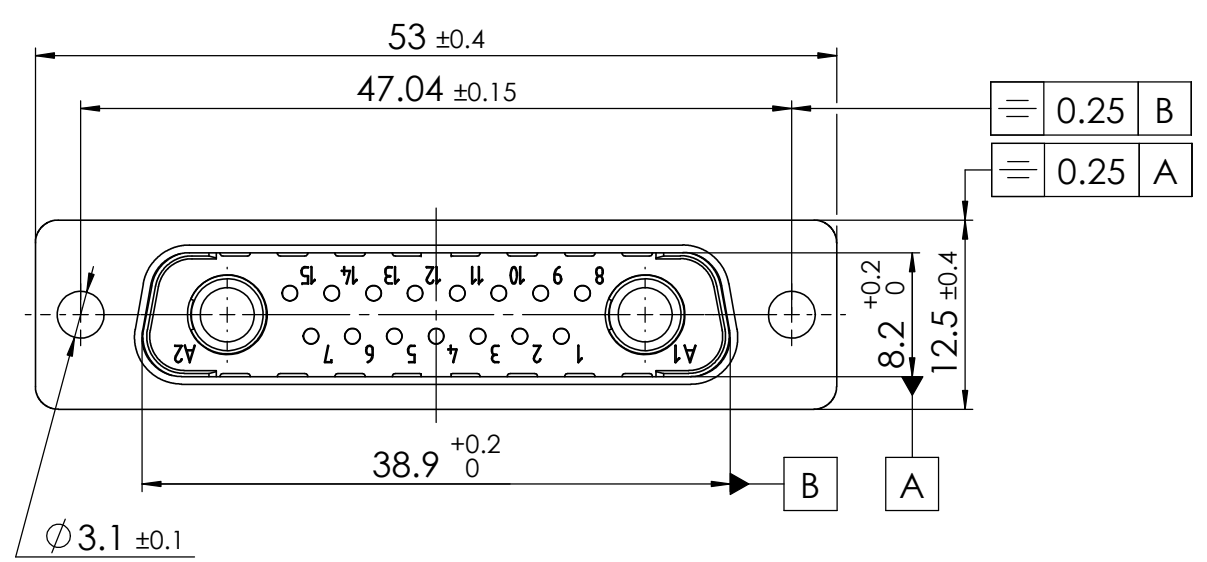

RoHS compliant

max. torque are 40 Ncm
 Part-No. 9 and 10 not mounted

No.	St.	Part	Type	Description / Material	Surface plating / Colour / Class
10	2	High power contact	FMP006P204		AuroPur / 20A / AWG 12-16
9	1	Rubber bushing	TPE		black
8	2	Locking screw	FVS1/5-K1163 4-40 / Steel		nickel plated
7	2	Cable reduction plate	Zinc die-cast		nickel plated
6	1	Strain relief	ABS		nickel plated
5	1	Cable clamp	Steel		tin plated
4	4	Screw	Case hardened steel		zinc plated
3	2	Catch spring	PEI		black
2	1	Hood	FMK3G / Zinc die-cast		nickel plated
1	1	Mixed-Layout Connector	FM17W2PA-K120		

		SCALE	TITLE
DRAWN ameyerrichte 13-10-2016		2:1	Hood Connector Set
CHECKED BWittef 14-10-2016			
		DWG.NO.	REV.
		FMK3G-17W2PA-5937	1
1	REV.	DATE	CH.-NO.
		ORIGINAL: DIN A3-DRAWING AS A FILE	REPLACEMENT FOR:
			PAGES 1

COMMENT: ALL RIGHTS ARE RESERVED BY US FOR THIS DRAWING. WITHOUT OUR PRIOR CONSENT, IT MAY NEITHER BE DUBLICATED NOR MADE AVAILABLE TO A THIRD PARTY. AND IT ALSO MAY NOT BE IMPROPERLY USED BY THE RECEIVER, OR A THIRD PARTY.