

U.I. Lapp GmbH	DATASHEET	
	SKINDICHT® CN	52032570 14.11.2013

For high temperatures
Resistant to oils, solvents, acids and chemicals
Seawater-resistant
For high mechanical stress
High corrosion-resistance



Good chemical resistance



Corrosion-resistant



Robust



Temperature-resistant



Application range

Chromium nickel steel cable gland with VITON® seal, specially designed for use under tough conditions.
Pharmaceutical and petrochemical industry
Offshore sector
Wind power plants
Brickworks

Design

PG connection thread

Note

Refer to the chart to find a suitable counter-nut for SKINDICHT® SM CrNi

Remark

Viton® is a registered trademark of DuPont de Nemours
Photographs are not to scale and do not represent detailed images of the respective products.

Product Management	Document: SKINDICHT® CN	1 / 3
--------------------	-------------------------	-------

U.I. Lapp GmbH	DATASHEET	 LAPP GROUP
	SKINDICHT® CN	52032570 14.11.2013

Technical Data

Article designation / size:	CN 29
Clamping range ØF (mm):	19 - 27,5
SW (mm):	41
Overall length, C (mm):	53
Thread length, D (mm):	12
Pieces / PU:	5
Caution:	The installation dimensions can be found in appendix T21
On request:	TPE seal
Material:	Body: Chrome-nickel steel in accordance with DIN, material no. 1.4305 Seal: FPM O-ring: FPM
Protection rating:	IP 68
Temperature range:	-25°C to +200°C

Product Management	Document: SKINDICHT® CN	2 / 3
--------------------	-------------------------	-------

U.I. Lapp GmbH	DATASHEET	 LAPP GROUP
	SKINDICHT® CN	52032570 14.11.2013

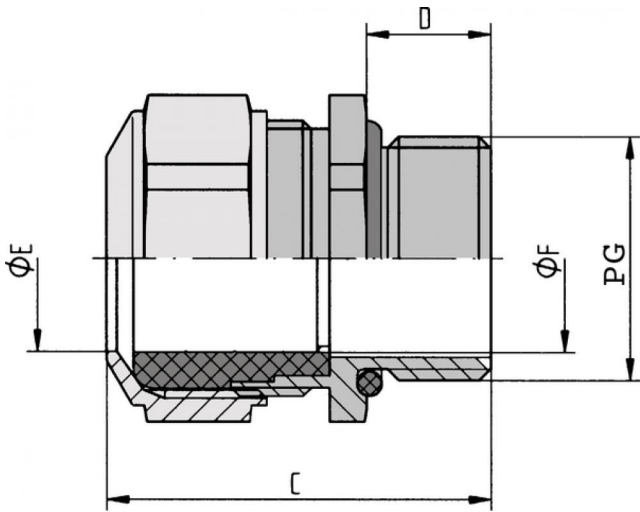

Product Management	Document: SKINDICHT® CN	3 / 3
--------------------	-------------------------	-------