

Locking Assemblies COM-CB2

Material: Steel.

- For fixing a hub (e.g. spur toothed gear or similar) on a shaft.
- For medium high torques.
- Self-centering.
- Self-locking.
- No axial movement during mounting.

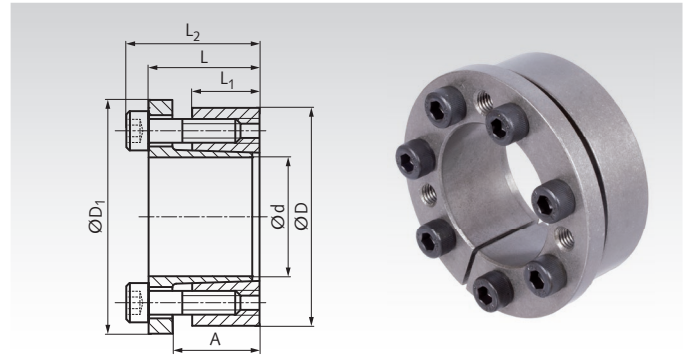

Ordering Details: e.g.: Product No. 615 575 18, Locking Assembly COM-CB2, 18 mm

Product No.	d mm	D mm	L mm	A mm	L ₁ mm	L ₂ mm	D ₁ mm	T Nm	F _{ax} kN	P _w N/mm ²	P _N N/mm ²	Screw 12.9 Number x Size	T _A Nm	Weight kg
615 575 18	18	47	28	22	17	34	54	270	28	212	94	5 x M6	17	0,30
615 575 19	19	47	28	22	17	34	54	274	28	215	93	5 x M6	17	0,30
615 575 20	20	47	28	22	17	34	54	280	28	218	94	5 x M6	17	0,32
615 575 22	22	47	28	22	17	34	54	300	28	200	95	5 x M6	17	0,32
615 575 24	24	50	28	22	17	34	57	330	28	178	89	6 x M6	17	0,35
615 575 25	25	50	28	22	17	34	57	420	34	210	105	6 x M6	17	0,32
615 575 28	28	55	28	22	17	34	62	480	34	196	98	6 x M6	17	0,37
615 575 30	30	55	28	22	17	34	62	510	35	177	96	6 x M6	17	0,37
615 575 32	32	60	28	22	17	34	67	730	40	222	116	8 x M6	17	0,39
615 575 35	35	60	28	22	17	34	67	770	44	194	112	8 x M6	17	0,39
615 575 38	38	65	28	22	17	34	72	830	45	181	103	8 x M6	17	0,46
615 575 40	40	65	28	22	17	34	72	940	50	182	109	8 x M6	17	0,46
615 575 42	42	75	33	25	20	41	82	1590	70	234	130	7 x M8	41	0,72
615 575 45	45	75	33	25	20	41	82	1630	70	213	124	7 x M8	41	0,70
615 575 48	48	80	33	25	20	41	87	1740	70	198	119	7 x M8	41	0,80
615 575 50	50	80	33	25	20	41	87	1830	80	195	120	7 x M8	41	0,77
615 575 55	55	85	33	25	20	41	92	2210	80	192	125	8 x M8	41	0,80
615 575 60	60	90	33	25	20	41	97	2410	80	178	120	8 x M8	41	0,88
615 575 65	65	95	33	25	20	41	102	3090	90	192	131	9 x M8	41	0,93
615 575 70	70	110	40	30	24	50	117	4620	130	208	134	8 x M10	83	1,60
615 575 75	75	115	40	30	24	50	122	4900	130	191	123	8 x M10	83	1,76
615 575 80	80	120	40	30	24	50	127	5000	130	176	119	8 x M10	83	1,81
615 575 85	85	125	40	30	24	50	132	6300	150	195	135	9 x M10	83	1,90
615 575 90	90	130	40	30	24	50	137	6800	150	187	131	9 x M10	83	2,0
615 575 95	95	135	40	30	24	50	142	7700	160	191	132	10 x M10	83	2,1
615 576 00	100	145	44	32	26	56	152	9800	190	202	141	8 x M12	145	2,8

More sizes up to d=200mm for 48,000Nm are available.

Price and delivery time on request.

T = transmittable torque at $F_{ax} = 0$.
 F_{ax} = transmittable axial force at $T = 0$.
 P_w = surface pressure onto the shaft.
 P_N = surface pressure onto the hub.
 T_A = fastening torque of the screws.

Fit

Shaft h8, Hub H8.
 Surface roughness R_z
 max. 12.5 μm .

Mounting

Slightly oil the locking assembly before mounting, do not use molybdenum disulphide or grease. Tighten the screws evenly and crosswise in several steps.

Demounting

Remove all tensioning screws and screw them into the (usually unused) forcing thread of the front flange, until the flange is released.