

# IIM209

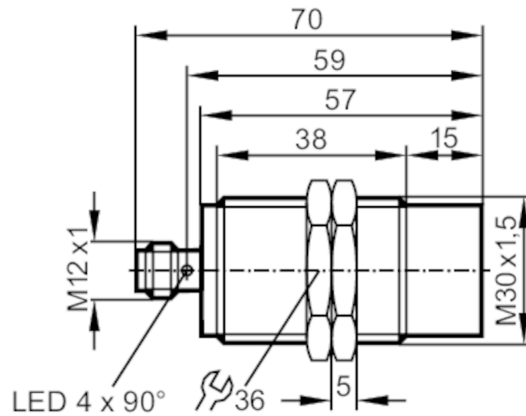

## Inductive sensor

IIK3022-BPKG/M/60V/US-104



### Product characteristics

Electrical design	PNP
Output function	normally open
Sensing range [mm]	22
Housing	threaded type
Dimensions [mm]	M30 x 1.5 / L = 70

### Application

Special feature	Gold-plated contacts; Increased sensing range
Application	Use in mobile and harsh applications

### Electrical data

Operating voltage [V]	10...60 DC
Current consumption [mA]	< 10
Protection class	II
Reverse polarity protection	yes

### Outputs

Electrical design	PNP
Output function	normally open
Max. voltage drop switching output DC [V]	2.5
Permanent current rating of switching output DC [mA]	200
Switching frequency DC [Hz]	100
Short-circuit protection	yes
Overload protection	yes

### Detection zone

Sensing range [mm]	22
Real sensing range Sr [mm]	22 ± 10 %
Operating distance [mm]	0...17.82
Increased sensing range	yes



## Inductive sensor

IHK3022-BPKG/M/60V/US-104

Accuracy / deviations		
Correction factor	steel: 1 / stainless steel: 0.7 / brass: 0.5 / aluminium: 0.45 / copper: 0.35	
Hysteresis [% of Sr]	1...20	
Switch point drift [% of Sr]	-10...10	
Operating conditions		
Ambient temperature [°C]	-40...85	
Protection	IP 67; IP 69K	
Tests / approvals		
EMC	automotive area	
	noise emission and noise interference according to the automotive directive 95/54/EC	E1 type approval
	noise immunity according to DIN ISO 11452-2	100 V/m
	conducted interference acc. to ISO 7637-2	
	pulse	1 2 3a 3b 4 5
	severity level	IV IV IV IV IV IV
	failure criterion	C C A A A C
	EN 61000-4-2 ESD	4 kV CD / 8 kV AD
	EN 61000-4-3 HF radiated	10 V/m
	EN 61000-4-4 Burst	2 kV
	EN 61000-4-5 Surge	0,5 kV mains line to line
	EN 61000-4-6 HF conducted	10 V
	EN 55011	class B
	EN 60068-2-6 Fc	20 g (10...3000 Hz) / -20...50 °C
Vibration resistance	50 sweep cycles per frequency; 1 octave per minute in 3 axes	
Shock resistance	100 g 11 ms half-sine; 3 shocks each in every direction of the 3 coordinate axes / -40...85 °C	
Continuous shock resistance	40 g 6 ms; 4000 shocks each in every direction of the 3 coordinate axes / -20...50 °C	
Fast temperature change	TA = -40 °C; TB = 85 °C; t1 = 30 min; t2 = < 10 s; 50 cycles	
Salt spray test	EN 60068-2-52 Kb severity level 5 (4 test cycles)	
MTTF [years]	900	
UL approval	Ta	0...40 °C
	Enclosure type	Type 1
	voltage supply	Class 2
	File number UL	E174191
Mechanical data		
Weight [g]	117.8	
Housing	threaded type	
Mounting	non-flush mountable	
Dimensions [mm]	M30 x 1.5 / L = 70	
Thread designation	M30 x 1.5	
Materials	threaded sleeve: stainless steel; sensing face: LCP natural; connector housing: PEI; lock nuts: brass	

# IIM209



## Inductive sensor

IHK3022-BPKG/M/60V/US-104

Displays / operating elements		
Display	switching status	4 x 90° LED, yellow
Accessories		
Accessories (supplied)	lock nuts: 2	
Remarks		
Pack quantity	1 pcs.	

### Electrical connection - plug

Connector: 1 x M12; Contacts: gold-plated



### Connection

