

RoHS
Compliant

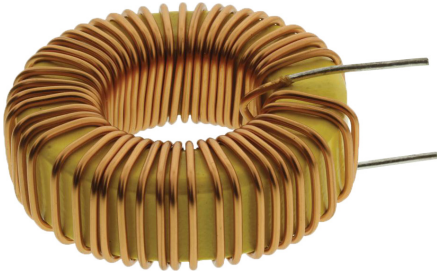

Schematic Diagram

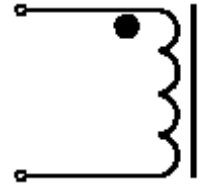

Note:

1. Wire UEFN/U Ø1mm (155°C)
2. 49TS (Reference) C.W

Configurations and Dimensions

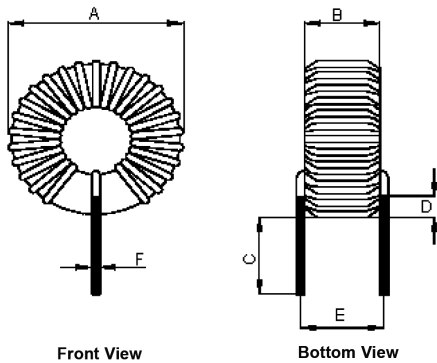

A	43mm (Max.)
B	15mm (Max.)
C	12 ±1mm
D	1mm (Min.)
E	13 ±1.5mm
F	Ø1.1mm (Max.)

Test Data for Mechanical

Test Item	A mm	B mm	C mm	D mm	E mm	F mm
Specification	43 (Max.)	15 (Max.)	12 ±1	1 (Min.)	13 ±1.5	Ø1.1 (Max.)
1	41.75	14.13	11.11	4.48	13.89	1.02
2	41.67	14.21	11.23	3.47	13.67	1.03
3	41.85	14.24	11.7	4.14	13.46	0.99
4	41.81	14.06	11.93	3.46	13.66	0.97
5	41.83	14.11	11.59	4.12		1.01
Average	41.78	14.15	11.51	3.93	13.67	1

Electrical Characteristics

Test Condition		
10kHz / 5 mA	L	220µH ±20%
T _A = 25°C	DCR	60mΩ (Max.)
10kHz / 5mA I _{rms} = 11A	ΔT	Temperature rise 40°C (Max.)

Operating temperature : -55°C to +130°C

Newark.com/multicomp-pro
Farnell.com/multicomp-pro
Element14.com/multicomp-pro

Reliability Test

Test Item	Specifications	Test Method and Remarks
Operating temperature range	-55°C to +130°C	Including temperature rise due to self-generated heat.
Storage condition	Ambient temperature : 0°C to 40°C Humidity : Below 70% RH	To maintain the solderability of terminal electrodes, care must be taken to control temperature and humidity in the storage area.
Moisture sensitivity	Appearance : No abnormality No damage DCR change : Within ±5% Inductance change : Within ±5%	According to J-STD-020B level 3 Test condition : 60°C 60% RH Test duration : 40 hrs Recovery : 1 to 2 hours of recovery under the standard condition after the removal from the test chamber.
Solderability	All termination shall exhibit a continuous solder coating free from defects for a minimum of 95% of the surface area of any individual lead.	According to J-STD-002B Steam aging category : 97°C 98% RH Steam aging duration : 8 hrs Solder : Lead-free solder Solder temperature : 260 ±5°C Dip time : 5 +0 / -0.5s

Test Data for Electrical

Test Item	L μH	DCR mΩ	ΔT
Condition	10kHz / 5mA	at 25°C	10kHz / 5mA I _{rms} = 11A
Specification	220 ±20%	60 (Max.)	Temperature rise 40°C (Max.)
1	220.2	45.74	OK
2	220.6	45.94	
3	220.1	45.58	
4	217.8	45.38	
5	221.9	45.76	
Average	220.12	45.68	OK

Material List

No.	Item	Material Description
1	Core	T150-75H-TAF200 (Red / White)
2	Wire	Ø1mm UEFN/U (155°C)
3	Solder	Sn99.3% / Cu0.7%

Electric Characteristics

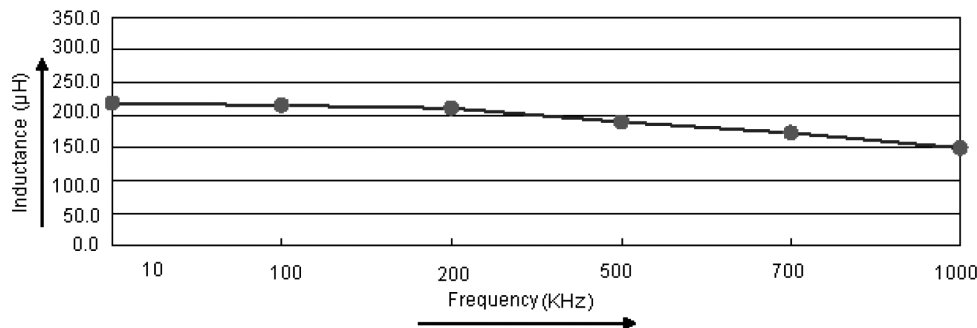
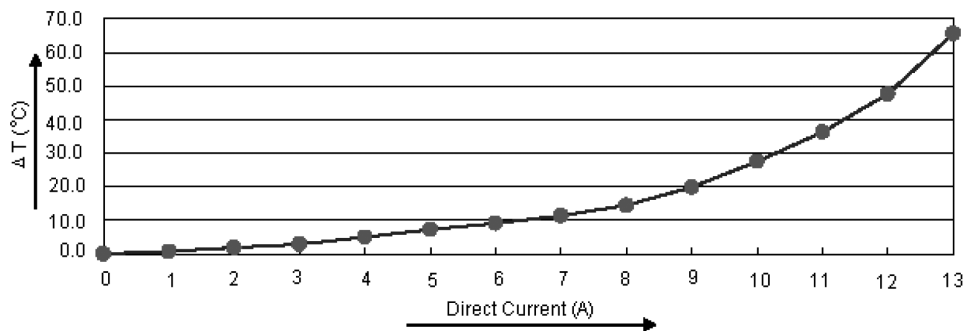
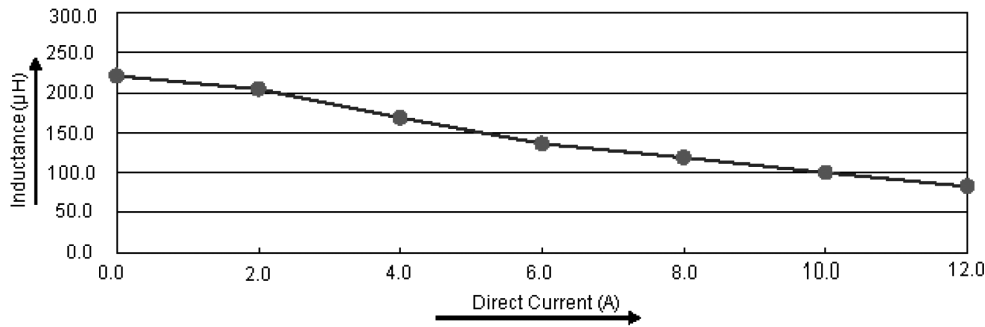

Part Number Table

Description	Part Number
Inductor, 220µH, 20%, 2 Pins	MCAP115018047A-221MU

Important Notice : This data sheet and its contents (the "Information") belong to the members of the AVNET group of companies (the "Group") or are licensed to it. No licence is granted for the use of it other than for information purposes in connection with the products to which it relates. No licence of any intellectual property rights is granted. The Information is subject to change without notice and replaces all data sheets previously supplied. The Information supplied is believed to be accurate but the Group assumes no responsibility for its accuracy or completeness, any error in or omission from it or for any use made of it. Users of this data sheet should check for themselves the Information and the suitability of the products for their purpose and not make any assumptions based on information included or omitted. Liability for loss or damage resulting from any reliance on the Information or use of it (including liability resulting from negligence or where the Group was aware of the possibility of such loss or damage arising) is excluded. This will not operate to limit or restrict the Group's liability for death or personal injury resulting from its negligence. Multicomp Pro is the registered trademark of Premier Farnell Limited 2019.