



MPQ18021HN-A

100V, 2.5A, High-Frequency, Half-Bridge Gate Driver AEC-Q100 Qualified

DESCRIPTION

The MPQ18021HN-A is a high-frequency, 100V, half-bridge, N-channel power MOSFET driver. Its low-side and high-side driver channels are controlled independently and matched with a time delay of less than 5ns. Under-voltage lockout (UVLO) on both the high-side and low-side supplies force their outputs low in the case of an insufficient supply. The integrated bootstrap diode reduces the external component count.

The MPQ18021HN-A is available in a cost-effective SOIC-8E package.

FEATURES

- Guaranteed Industrial / Automotive Temperature Range Limits
- Drives N-Channel MOSFET Half-Bridge
- 100V V_{BST} Voltage Range
- On-Chip Bootstrap Diode
- Typical 16ns Propagation Delay Time
- Less than 5ns Gate Drive Matching
- Drives 1nf Load with 12ns/9ns Rise/Fall Times with 12V VDD
- TTL-Compatible Input
- Less than 160 μ A Quiescent Current
- UVLO for both High-Side and Low-Side
- Available in a SOIC-8E Package
- Available in AEC-Q100 Qualified Grade 1

APPLICATIONS

- Car DC/DC Power Systems
- Half Bridge Motor Drivers

All MPS parts are lead-free, halogen-free, and adhere to the RoHS directive. For MPS green status, please visit the MPS website under Quality Assurance. "MPS", the MPS logo, and "Simple, Easy Solutions" are trademarks of Monolithic Power Systems, Inc. or its subsidiaries.

TYPICAL APPLICATION

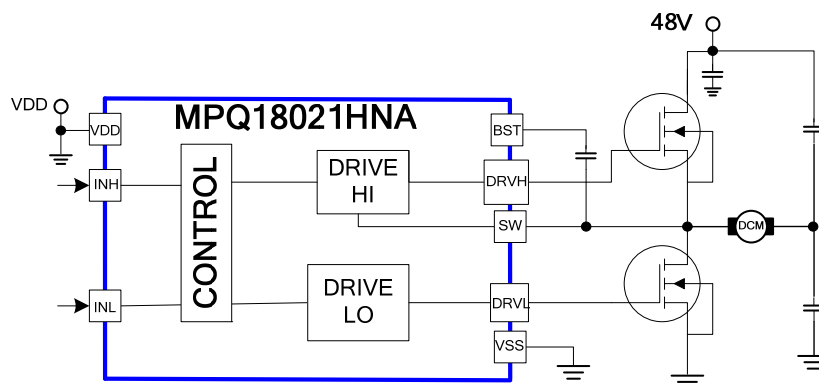

ORDERING INFORMATION

Part Number	Package	Top Marking
MPQ18021HN-A-AEC1	SOIC-8E	See Below

* For Tape & Reel, add suffix -Z (e.g. MPQ18021HN-A-AEC1-Z).

TOP MARKING

MP18021A

LLLLLLLL

MPSYWW

MP18021A: Part number
 LLLLLLLL: Lot number
 MPS: MPS prefix
 Y: Year code
 WW: Week code

PACKAGE REFERENCE

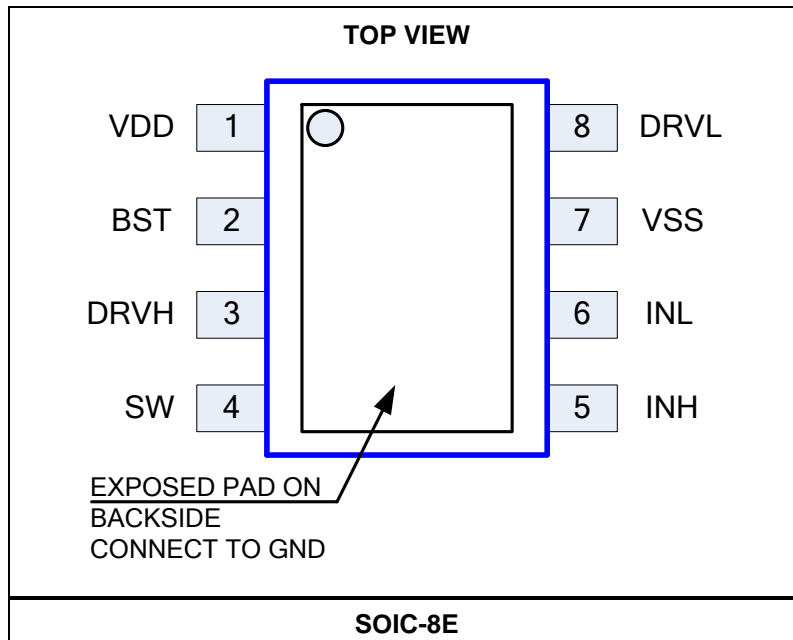

PIN FUNCTIONS

Pin #	Name	Description
1	VDD	Supply input. VDD supplies power to all of the internal circuitries. Place a decoupling capacitor to ground close to VDD to ensure a stable and clean supply.
2	BST	Bootstrap. BST is the positive power supply for the internal floating high-side MOSFET driver. Connect a bypass capacitor between BST and SW.
3	DRVH	Floating high-side driver output.
4	SW	Switching node.
5	INH	Control signal input for the floating driver.
6	INL	Control signal input for the low-side driver.
7	VSS	Chip ground. Connect the exposed pad to VSS for proper thermal operation.
Exposed Pad		
8	DRVL	Low-side driver output.

ABSOLUTE MAXIMUM RATINGS ⁽¹⁾

Supply voltage (V_{DD})	-0.3V to +18V
SW voltage (V_{HS})	-5.0V to +110V
BST voltage (V_{HB})	-0.3V to +110V
BST to SW	-0.3V to +18V
DRVH to SW	-0.3V to (BST - SW) + 0.3V
DRVL to VSS	-0.3V to (VDD + 0.3V)
All other pins	-0.3V to (VDD + 0.3V)
CDM rating (AEC-Q100-011C1)	
All pins	Class C6
HBM rating (AEC-Q100-002)	
BST, DRVH	Class H1B
SW	Class H1C
Other pins	Class H2
Continuous power dissipation ($T_A = 25^\circ\text{C}$) ⁽²⁾	2.5W
Junction temperature	150°C
Lead temperature	260°C
Storage temperature	-65°C to +150°C

Recommended Operating Conditions ⁽³⁾

Supply voltage (V_{DD})	9.0V to 16V
SW voltage (V_{HS})	-1.0V to +100V - VDD
SW slew rate	<50V/ns
Operation junction temp. (T_J)	-40°C to +125°C

Thermal Resistance ⁽⁴⁾	θ_{JA}	θ_{JC}
SOIC-8E	50	12 ... °C/W

NOTES:

- Exceeding these ratings may damage the device.
- The maximum allowable power dissipation is a function of the maximum junction temperature $T_J(\text{MAX})$, the junction-to-ambient thermal resistance θ_{JA} , and the ambient temperature T_A . The maximum allowable continuous power dissipation at any ambient temperature is calculated by $P_D(\text{MAX}) = (T_J(\text{MAX}) - T_A) / \theta_{JA}$. Exceeding the maximum allowable power dissipation produces an excessive die temperature, causing the regulator to go into thermal shutdown. Internal thermal shutdown circuitry protects the device from permanent damage.
- The device is not guaranteed to function outside of its operating conditions.
- Measured on JESD51-7, 4-layer PCB.

**ELECTRICAL CHARACTERISTICS**

$V_{DD} = V_{BST} - V_{SW} = 12V$, $V_{SS} = V_{SW} = 0V$, no load at DRVH and DRVL, $T_J = -40^{\circ}C$ to $+125^{\circ}C$, typical values tested at $T_J = +25^{\circ}C$, unless otherwise noted.

Parameter	Symbol	Condition	Min	Typ	Max	Units
Supply Currents						
VDD quiescent current	I_{DDQ}	INH = INL = 0		120	160	μA
VDD operating current	I_{DDO}	$f_{sw} = 500kHz$		2.8	3.5	mA
Floating driver quiescent current	I_{BSTQ}	INH = INL = 0		70	100	μA
Floating driver operating current	I_{BSTO}	$f_{sw} = 500kHz$		2.1	3	mA
Leakage current	I_{LK}	HB = SW = 100V		0.05	2.5	μA
Inputs						
INL/INH high				2.2	2.6	V
INL/INH low			1	1.5		V
INL/INH internal pull-down resistance	R_{IN}			185		k Ω
Under-Voltage Protection (UVP)						
VDD rising threshold	V_{DDR}		7.4	8.1	8.9	V
VDD hysteresis	V_{DDH}			0.5		V
(BST-SW) rising threshold	V_{BSTR}		6.5	7.1	7.7	V
(BST-SW) hysteresis	V_{BSTH}			0.55		V
Bootstrap Diode						
Bootstrap diode VF @ 100 μA	V_{F1}			0.5		V
Bootstrap diode VF @ 100mA	V_{F2}			1		V
Bootstrap diode dynamic R	R_D	@ 100mA		2.5		Ω
Low Side Gate Driver						
Low-level output voltage	V_{OLL}	$I_o = 100mA$		0.15	0.32	V
High-level output voltage to rail	V_{OHL}	$I_o = -100mA$		0.45	1	V
Peak pull-up current ⁽⁵⁾	I_{OHL}	$V_{LO} = 0V, V_{DD} = 12V$		1.5		A
		$V_{LO} = 0V, V_{DD} = 16V$		2.5		A
Peak pull-down current ⁽⁵⁾	I_{OLL}	$V_{LO} = V_{DD} = 12V$		2.5		A
		$V_{LO} = V_{DD} = 16V$		3.5		A
Floating Gate Driver						
Low-level output voltage	V_{OLH}	$I_o = 100mA$		0.15	0.32	V
High-level output voltage to rail	V_{OHH}	$I_o = -100mA$		0.45	1	V
Peak pull-up current ⁽⁵⁾	I_{OHH}	$V_{HO} = 0V, V_{DD} = 12V$		1.5		A
		$V_{HO} = 0V, V_{DD} = 16V$		2.5		A
Peak pull-down current ⁽⁵⁾	I_{OLH}	$V_{HO} = V_{DD} = 12V$		2.5		A
		$V_{HO} = V_{DD} = 16V$		3.5		A
Switching spec – low-side gate driver						
Turn-off propagation delay INL falling to DRVL falling	T_{DLFF}			16		ns
Turn-on propagation delay INL rising to DRVL rising	T_{DLRR}			16		
DRVL rise time		$C_L = 1nF$		12		ns
DRVL fall time		$C_L = 1nF$		9		ns

ELECTRICAL CHARACTERISTICS (continued)

$V_{DD} = V_{BST} - V_{SW} = 12V$, $V_{SS} = V_{SW} = 0V$, no load at DRVH and DRVL, $T_J = -40^{\circ}C$ to $+125^{\circ}C$, typical values tested at $T_J = +25^{\circ}C$, unless otherwise noted.

Parameter	Symbol	Condition	Min	Typ	Max	Units
Switching Spec – Floating Gate Driver						
Turn-off propagation delay INL falling to DRVH falling	T_{DHFF}			16		ns
Turn-on propagation delay INL rising to DRVH rising	T_{DHRR}			16		ns
DRVH rise time		$C_L = 1nF$		12		ns
DRVH fall time		$C_L = 1nF$		9		ns
Switching Spec – Matching						
Floating driver turn-off to low-side drive turn-on ⁽⁵⁾	T_{MON}			1	5	ns
Low-side driver turn-off to floating driver turn-on ⁽⁵⁾	T_{MOFF}			1	5	ns
Minimum input pulse width that changes the output	T_{PW}				50 ⁽⁵⁾	ns
Bootstrap diode turn-on or turn-off time	T_{BS}			10 ⁽⁵⁾		ns
Thermal shutdown ⁽⁵⁾				170		$^{\circ}C$
Thermal shutdown hysteresis ⁽⁵⁾				25		$^{\circ}C$

NOTE:

5) Guaranteed by design.

TIMING DIAGRAM

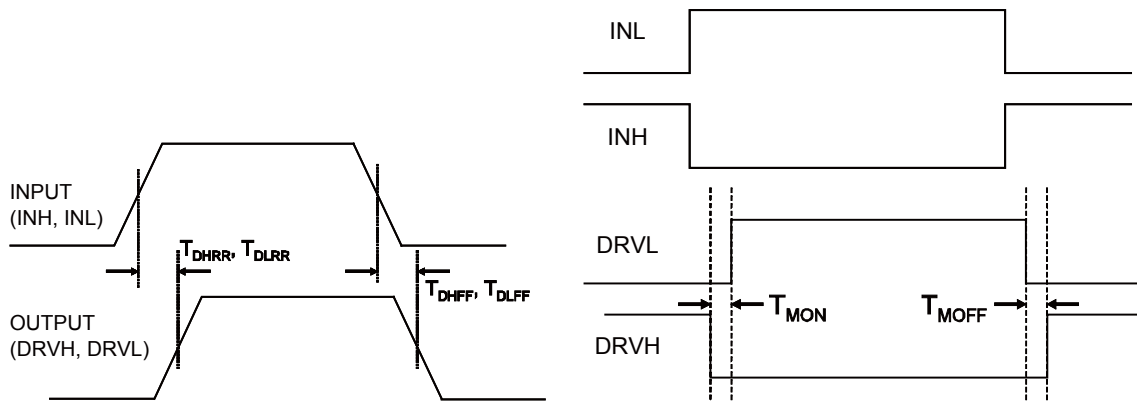

TYPICAL PERFORMANCE CHARACTERISTICS

$V_{DD} = 12V$, $V_{SS} = V_{SW} = 0V$, $T_A = 25^\circ C$, unless otherwise noted.

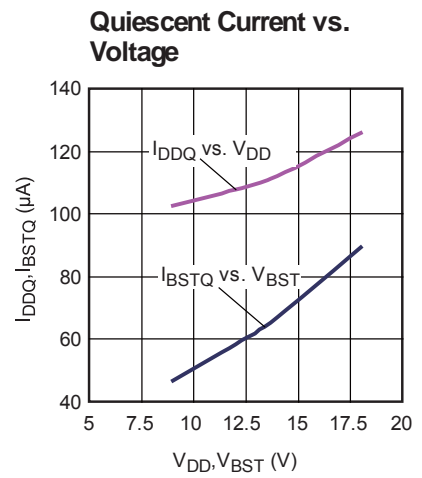
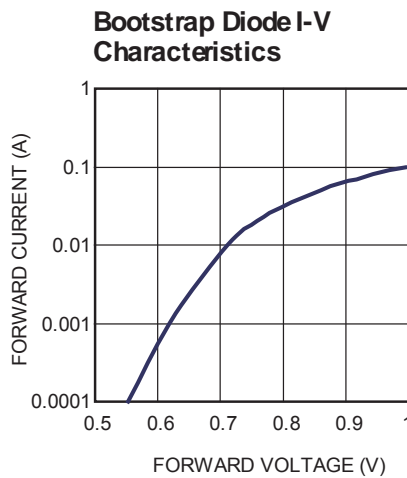
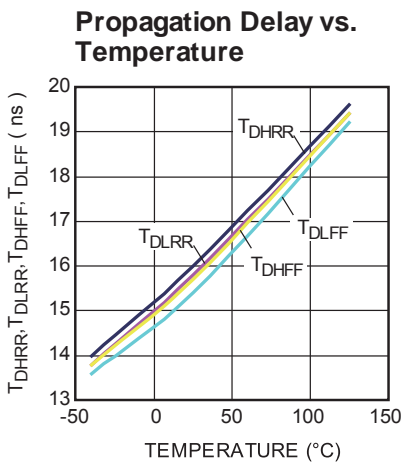
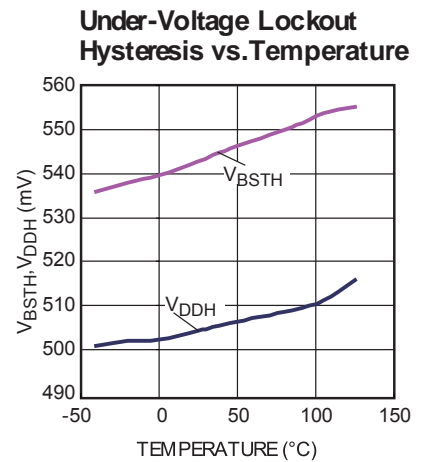
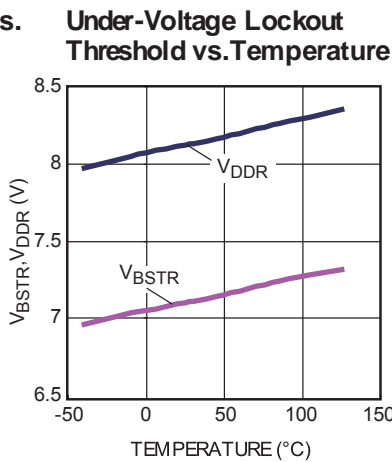
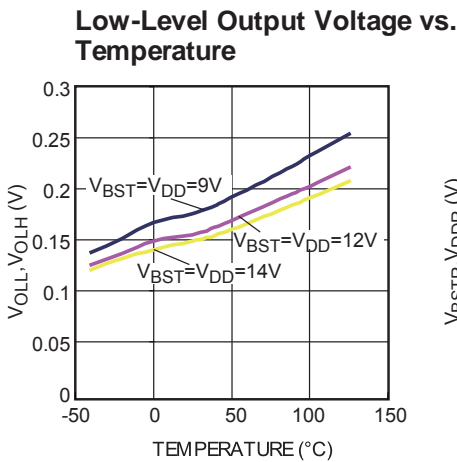
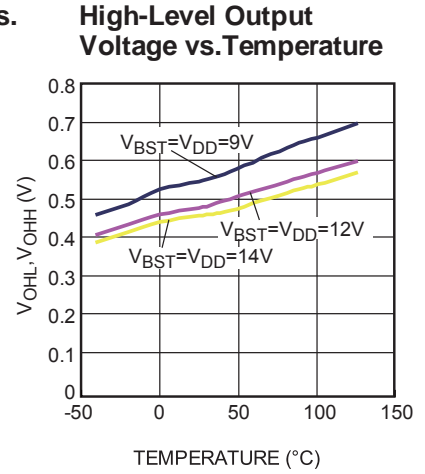
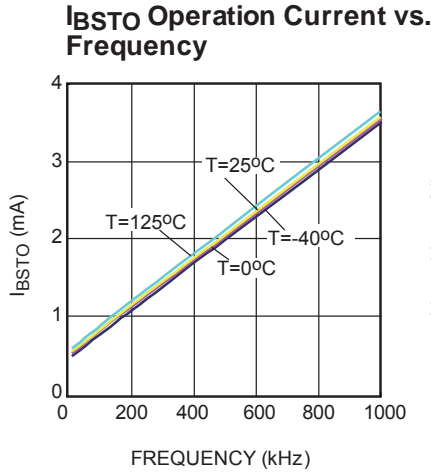
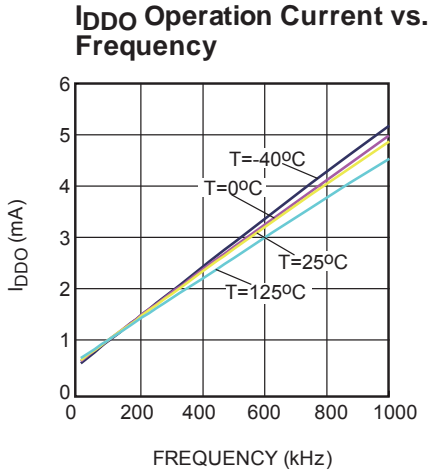

TYPICAL PERFORMANCE CHARACTERISTICS (continued)

$V_{DD} = 12V$, $V_{SS} = V_{SW} = 0V$, $T_A = 25^\circ C$, unless otherwise noted.

Peak Current vs. V_{DD} Voltage

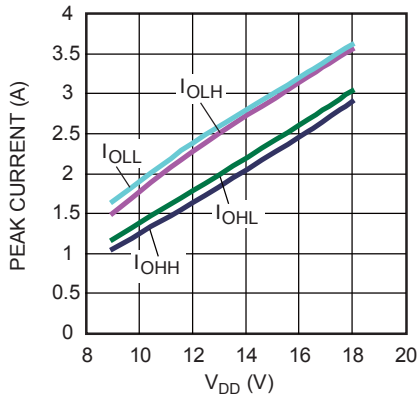

Turn-On Propagation Delay

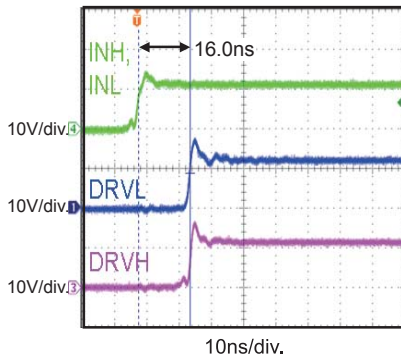

Gate Drive Matching T_{MOFF}

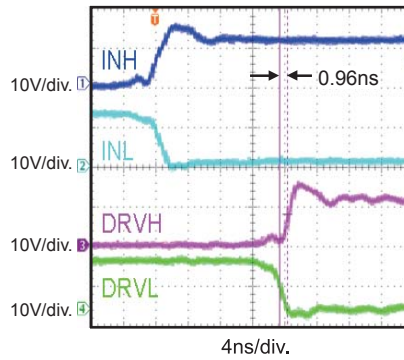

Drive Rise Time (1nF Load)

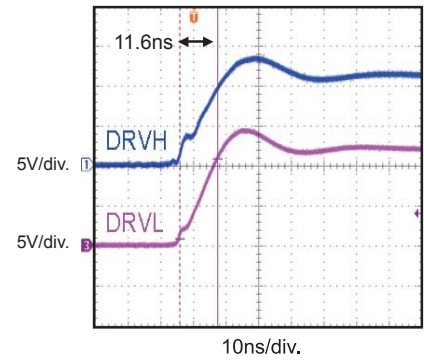

Turn-Off Propagation Delay

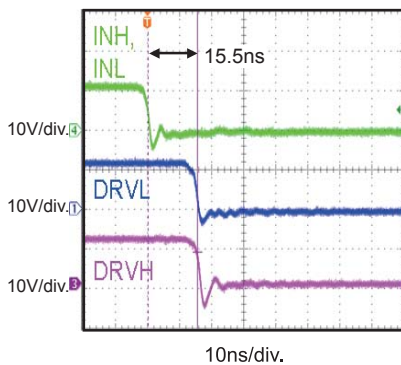

Gate Drive Matching T_{MON}

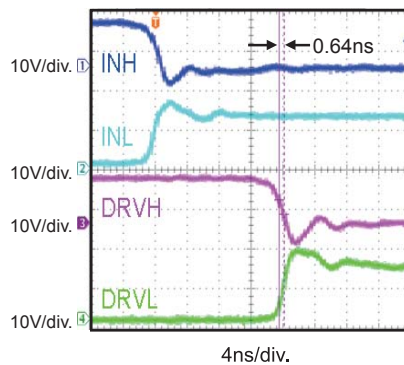

Drive Fall Time (1nF Load)

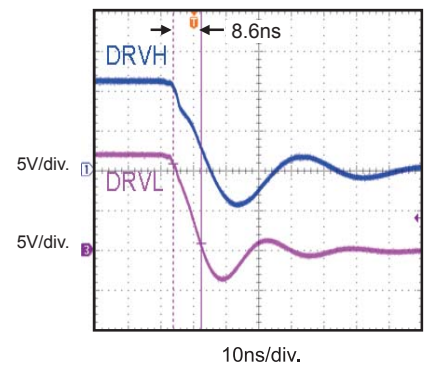

BLOCK DIAGRAM

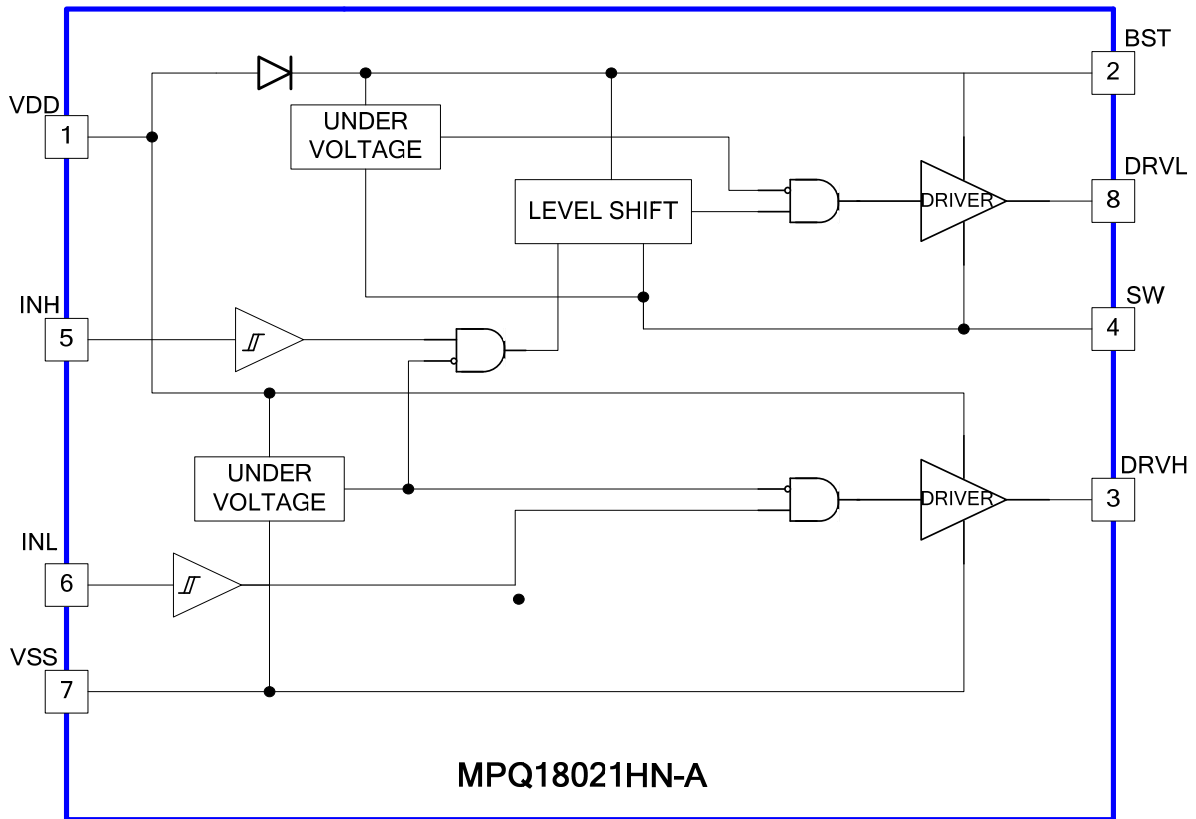

Figure 1: Functional Block Diagram

APPLICATION

The input signals of INH and INL can be controlled independently. If both INH and INL are controlling the high-side MOSFET (HS-FET) and low-side MOSFET (LS-FET) of the same bridge, shoot through can be prevented by setting a sufficient dead time between INH and INL low, and vice versa (see Figure 2). Dead time is defined as the time interval between INH low and INL low.

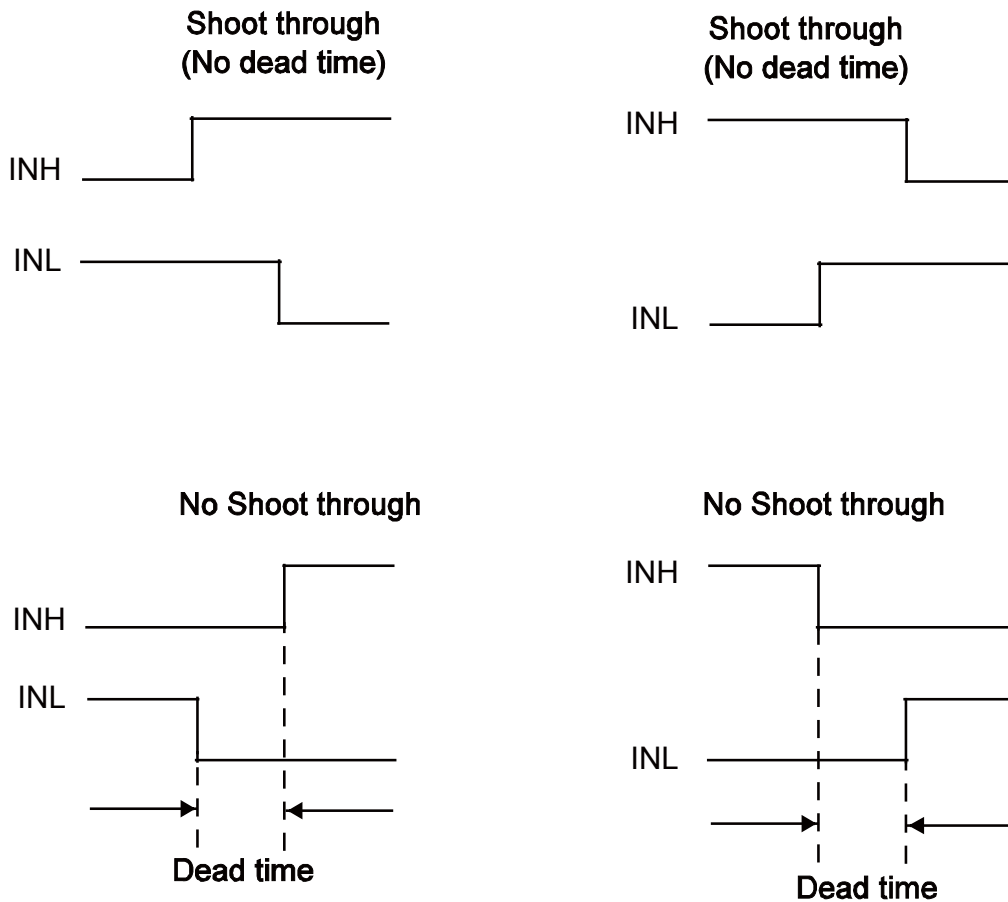

Figure 2: Shoot-Through Timing Diagram

REFERENCE DESIGN CIRCUITS

Half-Bridge Converter

In the half-bridge converter topology, the MOSFETs are driven alternately with some dead time. Therefore, INH and INL are driven

with alternating signals from the pulse-width modulation (PWM) controller. The input voltage can rise as high as 100V in this application (see Figure 3 through Figure 5).

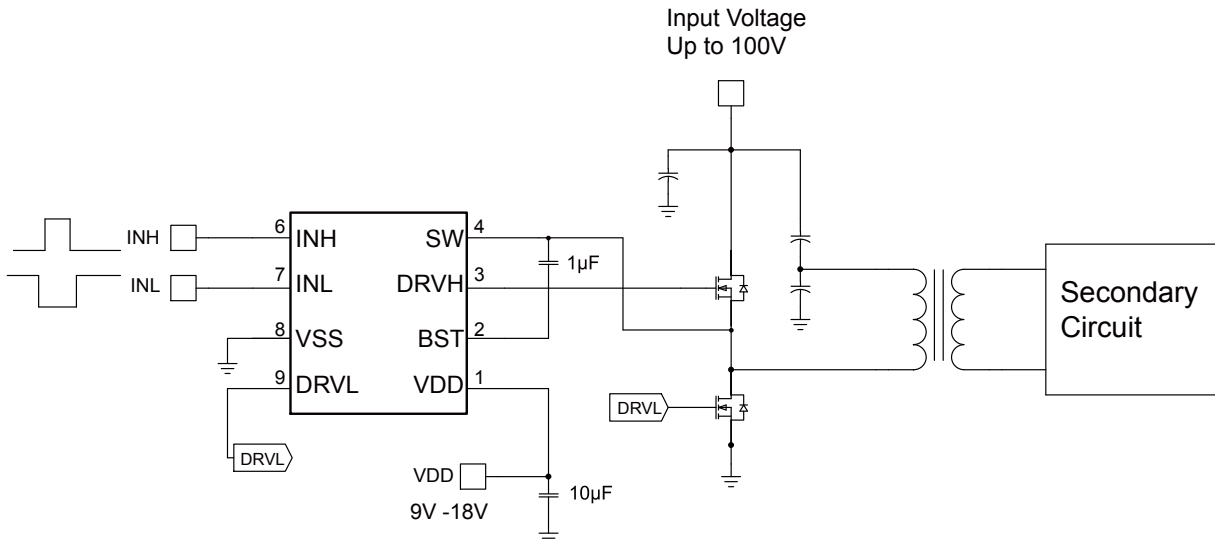

Figure 3: Half-Bridge Converter

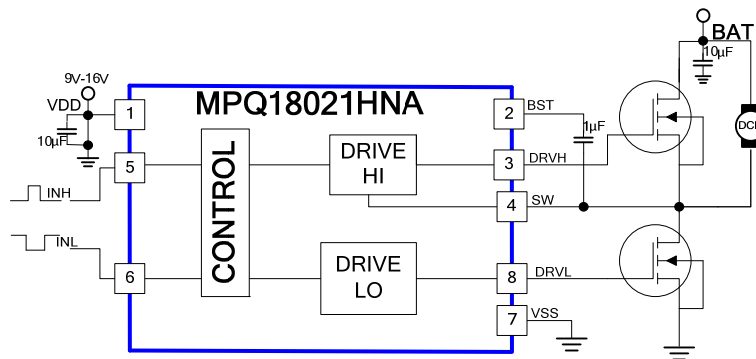

Figure 4: Half-Bridge for Unidirectional Motor

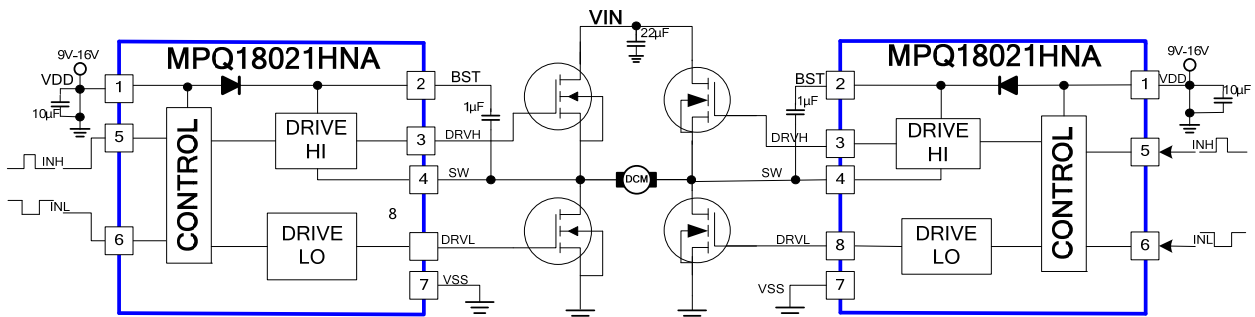
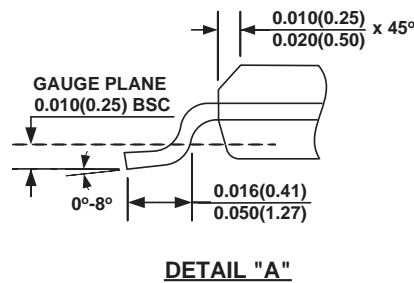
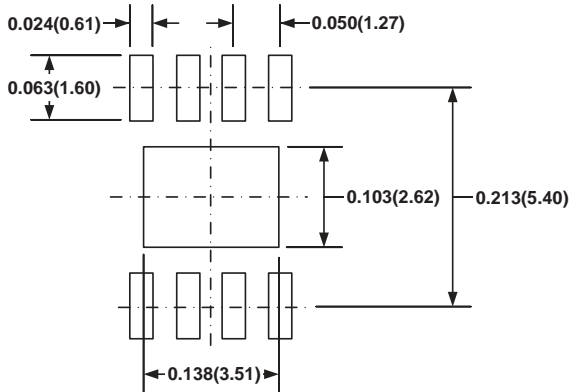
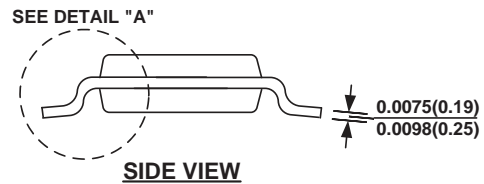
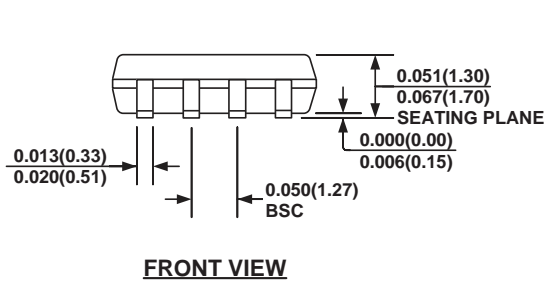
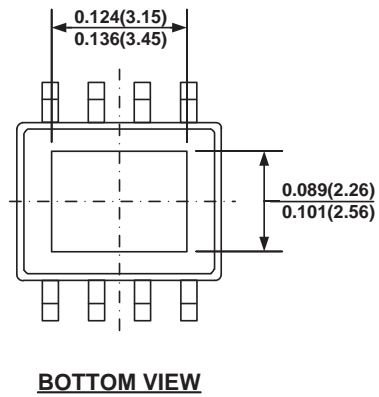
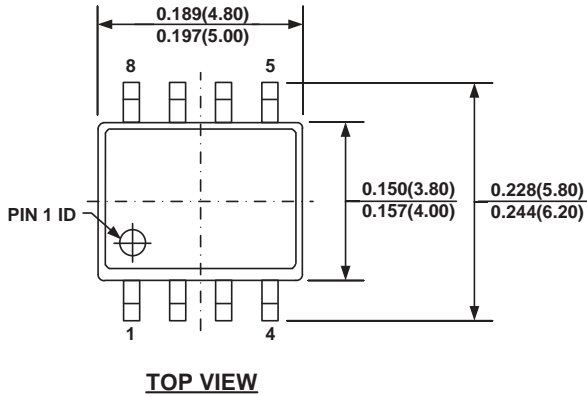

Figure 5: 2x MPQ18021HNA for One Bidirectional DC Motor

PACKAGE INFORMATION

SOIC-8E



NOTE:

- 1) CONTROL DIMENSION IS IN INCHES. DIMENSION IN BRACKET IS IN MILLIMETERS.
- 2) PACKAGE LENGTH DOES NOT INCLUDE MOLD FLASH, PROTRUSIONS OR GATE BURRS.
- 3) PACKAGE WIDTH DOES NOT INCLUDE INTERLEAD FLASH OR PROTRUSIONS.
- 4) LEAD COPLANARITY (BOTTOM OF LEADS AFTER FORMING) SHALL BE 0.004" INCHES MAX.
- 5) DRAWING CONFORMS TO JEDEC MS-012, VARIATION BA.
- 6) DRAWING IS NOT TO SCALE.

NOTICE: The information in this document is subject to change without notice. Users should warrant and guarantee that third party Intellectual Property rights are not infringed upon when integrating MPS products into any application. MPS will not assume any legal responsibility for any said applications.