

PRODUCT SPECIFICATION

Part Number	USB3155	Rev	A	Date	09/10/14		
Product Description	Micro USB Receptacle, Type B, SMT, Horizontal, Mid-Bottom Mount			Page	1		
Doc Number	USB3155	Prepared	AO	Checked	VJ	Approved	ST

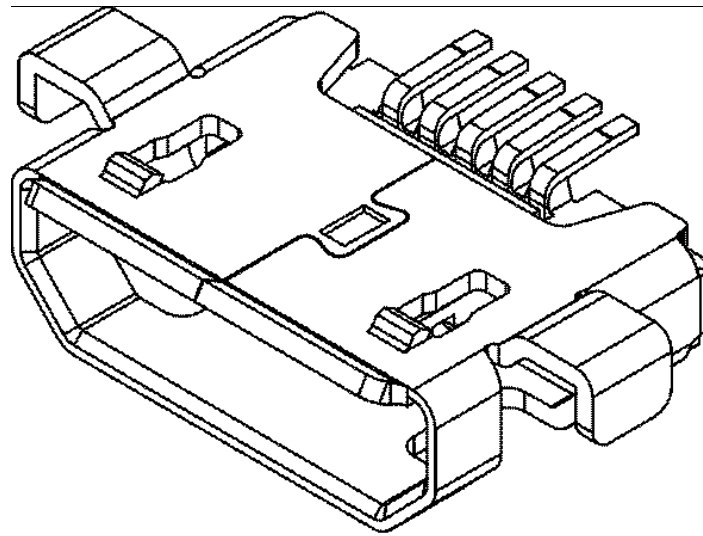

PRODUCT SPECIFICATION

Part Number	USB3155	Rev	A	Date	09/10/14		
Product Description	Micro USB Receptacle, Type B, SMT, Horizontal, Mid-Bottom Mount			Page	2		
Doc Number	USB3155	Prepared	AO	Checked	VJ	Approved	ST

1.0 SCOPE.

This specification covers performance, tests and quality requirements for the Micro USB Receptacle. USB3155 (Type B, SMT, Horizontal, Mid-Bottom Mount).

2.0 PRODUCT NAME AND PART NUMBER.

Micro USB Receptacle, 5 Pin, Type B: USB3155.

3.0 PRODUCT SHAPE, DIMENSIONS AND MATERIAL.

Please refer to drawings.

4.0 RATINGS.

- 4.1 Current rating: Signal (Pins 2, 3, 4) 1.0A
- Power (Pins1, 5)..... 1.8A
- 4.2 Voltage rating 30V AC
- 4.3 Operating Temperature Range -30°C to +85°C

5.0 TEST AND MEASUREMENT CONDITIONS.

Product is designed to meet electrical, mechanical and environmental performance requirements specified in Paragraph 6.0. All tests are performed in ambient conditions unless otherwise specified.

6.0 PERFORMANCE.

Item	Test Condition	Requirement
Examination of Product	Visual, dimensional and functional inspection as per quality plan.	Product shall meet requirements of product drawing and specification.

PRODUCT SPECIFICATION

Part Number	USB3155	Rev	A	Date	09/10/14		
Product Description	Micro USB Receptacle, Type B, SMT, Horizontal, Mid-Bottom Mount			Page	3		
Doc Number	USB3155	Prepared	AO	Checked	VJ	Approved	ST

6.1 Electrical Performance.

Item	Test Condition	Requirement
Low-signal Level Contact Resistance (initial)	Mate connectors, measure by dry circuit, 20 mV, 100mA Max. In accordance with EIA-364-23.	30 mΩ Max.
Insulation Resistance	Mate connectors, apply 100V DC for 1 minute at sea level between adjacent terminal or ground. In accordance with EIA-364-21.	1000 MΩ Min.
Dielectric Strength	Mate connectors, apply 100V AC for 1 minute at sea level. In accordance with EIA-364-20.	No Breakdown.

6.2 Mechanical Performance.

Item	Test Condition	Requirement
Mating/Un-mating Force (initial)	Mate/Un-mated at a rate of 12.5mm/min. In accordance with EIA-364-13.	Mating force: 35N Max. Un-Mating force: 8N Min. to 25N Max.
Durability	Cycle rate, 500 cycles per hour if done automatically and 200 if manual cycles. In accordance with EIA-364-09.	10,000 cycles. Low Level Contact Resistance: 10mΩ Max. change allowed Mating force: 35N Max. Un-Mating force: 8N Min. to 25N Max.
Vibration	Mate connectors and subject to 5.35 Gs RMS. For a period of 15 minutes in each of the 3 mutually perpendicular axes. In accordance with EIA-364-28 Test condition V test letter A.	Appearance: No Damage. Contact Resistance: 10mΩ Max. change allowed Discontinuity: 1.0μ second Max.
Mechanical Shock	Mate connectors and subject to the following shock conditions, 3 shocks shall be applied along 3 mutually perpendicular axis, passing 100 mA current during the test. (Total of 18 shocks) Test Pulse: Half Sine Peak Value: 294 m/s ² (30G) Duration: 11ms. In accordance with EIA-364-27. Test condition H.	Appearance: No Damage. Contact Resistance: 10mΩ Max. change allowed. Discontinuity: 1.0μ second Max.

PRODUCT SPECIFICATION

Part Number	USB3155	Rev	A		Date	09/10/14
Product Description	Micro USB Receptacle, Type B, SMT, Horizontal, Mid-Bottom Mount				Page	4
Doc Number	USB3155	Prepared	AO	Checked	VJ	Approved ST

6.3 Environmental Performance and Others.

Item	Test Condition	Requirement
Cyclic Humidity Test	Subject mated connectors to Duration: 168 hours(7 cycles) temperature between -25°C to +65°C with 90 to 95% RH. In accordance with EIA-364-31. Test condition A method III	Appearance: No Damage. Contact Resistance: 10mΩ Max. change allowed. Insulation Resistance: 1000 MΩ Min. Dielectric Strength: No Breakdown.
Salt Spray	Subject mated/unmated connectors to 5% salt-solution concentration, 35°C for 48 hours. In accordance with EIA-364-26, Test Condition B.	Low Level Contact Resistance: 50mΩ Max. No visible rust
Temperature Life	Subject mated connectors to temperature life at +85°C for 96hours. In accordance with EIA-364-17. Test condition 2 Method A.	Contact Resistance: 10mΩ Max. change allowed. no physical damage.
Temperature Rise	Mate connector and measure the temperature rise of contact when the maximum AC rated current is passed and in accordance with EIA-364-70.	+30°C Max. change allowed.
Thermal Shock	Mate module and subject to follow condition for 10 cycles. At -55°C to +85°C. In accordance with EIA-364-32, test condition I.	No Damage 10mΩ Max. change allowed.
Solderability	Dip solder-tails in flux then immerse in solder bath at 245 ±5°C up to 0.5mm from the bottom of the housing for 4~5 seconds. In accordance with EIA-364-52, category 2.	95% of immersed area must show no voids, pin holes.
Resistance to Soldering Heat (Reflow Soldering)	Sample mounted on PCB and subject to solder bath method, Temperature:260°C for 10±1 sec (High Temp. Thermoplastic). In accordance with EIA-364-56.	Without deformation of shell or excessive looseness of the terminals (pin.)
Resistance to Soldering Heat (Hand Soldering)	Sample mounted on PCB and subject to hand iron soldering, Temperature:350±10°C for 3±1 sec (High Temp. Thermoplastic).	Without deformation of shell or excessive looseness of the terminals (pin.)

PRODUCT SPECIFICATION

Part Number	USB3155	Rev	A	Date	09/10/14
Product Description	Micro USB Receptacle, Type B, SMT, Horizontal, Mid-Bottom Mount			Page	5
Doc Number	USB3155	Prepared	AO	Checked	VJ
				Approved	ST

7.0 RESISTANCE TO INFRARED REFLOW SOLDERING HEAT

7.1 Lead Free Process: Reflow soldering cycles limited to two times

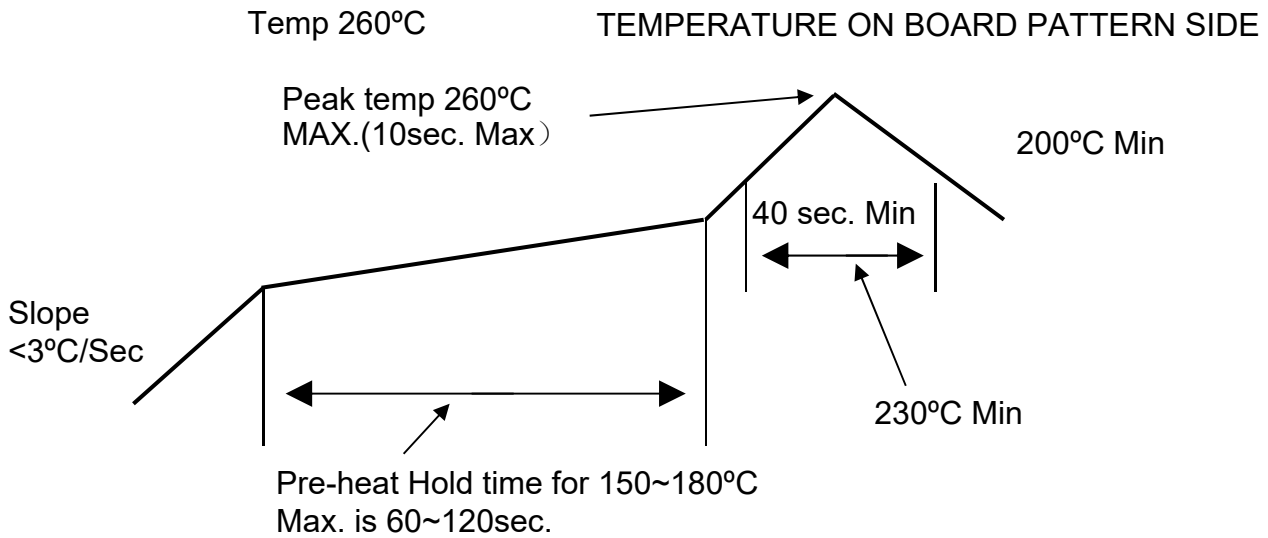

8.0 PRODUCT QUALIFICATION AND TEST SEQUENCE

Test Item	Test Group									
	A	B	C	D	E	F	G	H	I	
Examination of Product	1, 6	1, 7	1, 10	1, 5	1, 5		1, 3	1, 3	1, 3	
Low-signal Level Contact Resistance	2, 5	3, 6	4, 7	2, 4	2, 4					
Insulation Resistance			2, 8							
Dielectric Withstanding Voltage			3, 9							
Mating / Unmating Forces		2, 5								
Durability		4								
Vibration	4									
Mechanical Shock	3									
Humidity			6							
Salt Spray				3						
Temperature Life					3					
Temperature Rise						1				
Thermal Shock			5							
Solderability							2			
Resistance to Reflow Soldering Heat								2		
Resistance to Hand Soldering Heat									2	

PRODUCT SPECIFICATION

Part Number	USB3155	Rev	A	Date	09/10/14		
Product Description	Micro USB Receptacle, Type B, SMT, Horizontal, Mid-Bottom Mount			Page	6		
Doc Number	USB3155	Prepared	AO	Checked	VJ	Approved	ST

Revision details :-

Revision	Information	Page	Release Date
A	Specification released.	-	09/10/14