

DO NOT SCALE DRAWING

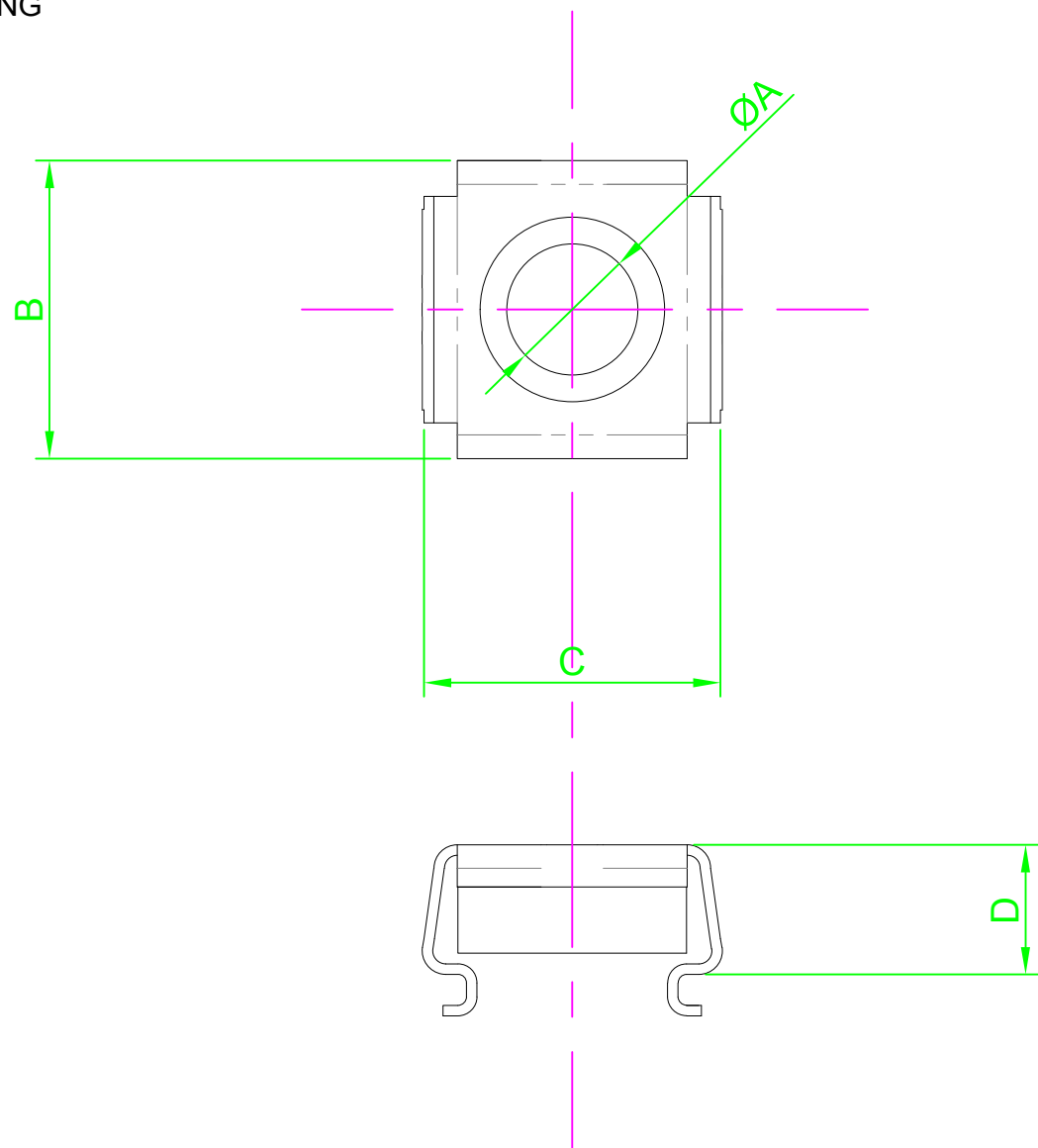

Recommended Mounting Hole

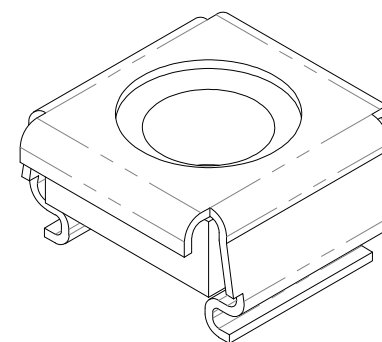
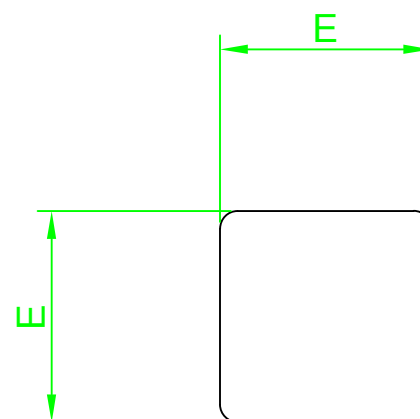

REVISION

A INITIAL DRAWING 04.02.16

Part Number	ØA	B Ref	C Ref	D Ref	E Ref	Panel Thickness
M5 - CNSTST BG25 CN/5M/WF	M5-0.8	13.14	13.84	6.00	9.53	1.7 - 2.5mm
M6 - CNSTST BG25 CN/6M/WF	M6-1.0					

NOTES:



DESIGN RIGHT. TR FASTENINGS LTD, 2003
UNDER NO CIRCUMSTANCES MUST THIS
DRAWING BE COPIED OR DISCLOSED
WITHOUT FIRST OBTAINING WRITTEN
AUTHORITY.

UNLESS OTHERWISE SPECIFIED:
DIMENSIONS ARE IN MM (MILLIMETERS).
SURFACE FINISH:
TOLERANCES:

	NAME	DATE
DRAWN	Darryl Wilson	04.02.16
CHK'D		
APPVD		

CUSTOMER PART NUMBER:
N/A

MATERIAL:
Steel

HEAT TREATMENT:

FINISH:
Zinc & Coloured Chromate Trivalent
De-Embrittle

TITLE:
Cage Nut

DRAWING NUMBER:
TR32CNSTSTB25WIDE

A4

PROJECTION

