

Inductors for decoupling circuits
Wound ferrite
ADL-VM series (for automobiles)



AEC-Q200

ADL3225VM type



FEATURES

- Small size and thin form factor (mounting area 3.2 x 2.5 mm, height 2.5mm max.)
- Achieving broadband impedance characteristics and good DC superimposition characteristics as the result of an original coiled wiring design and original structure
- Ensuring consistent high quality and reliability as the result of a completely automated manufacturing process
- Operating temperature range: -55 to +155°C (including self-temperature rise)
- Compliant with AEC-Q200

APPLICATION

- Inductor for use with separate signal and power lines in in-vehicle PoC (Power Over Coax)
- Application guides: [Car Infotainment](#)

PART NUMBER CONSTRUCTION

ADL	3225	VM	-	2R2	M	-	TL	000
Series name	LxWxH dimensions 3.2x2.5x2.5 mm	Characteristic type		Inductance (μH)	Inductance tolerance		Packaging style	Internal code

CHARACTERISTICS SPECIFICATION TABLE

L (μH)	L Measuring frequency Tolerance	DC resistance (kHz)	DC resistance (Ω) max.	Rated current*		Part No.		
				Isat (mA) typ. 105°C	Isat (mA) typ. 125°C	Itemp (mA) typ. 105°C	Itemp (mA) typ. 125°C	
2.2	±20%	100	0.18	1000	950	1220	1045	ADL3225VM-2R2M-TL000
15	±20%	100	0.40	350	310	725	625	ADL3225VM-150M-TL000

* Rated current: smaller value of either Isat or Itemp.

Isat: when based on the inductance change rate (30% below the nominal inductance value)

Itemp.105°C: When based on the temperature increase (temperature increase of 40°C by self heating)

Itemp.125°C: When based on the temperature increase (temperature increase of 30°C by self heating)

Measurement equipment

Measurement item	Product No.	Manufacturer
Inductance	4294A	Keysight Technologies
DC resistance	4338A	Keysight Technologies

* Equivalent measurement equipment may be used.

ADL3225VM type

■ IMPEDANCE VS. FREQUENCY CHARACTERISTICS

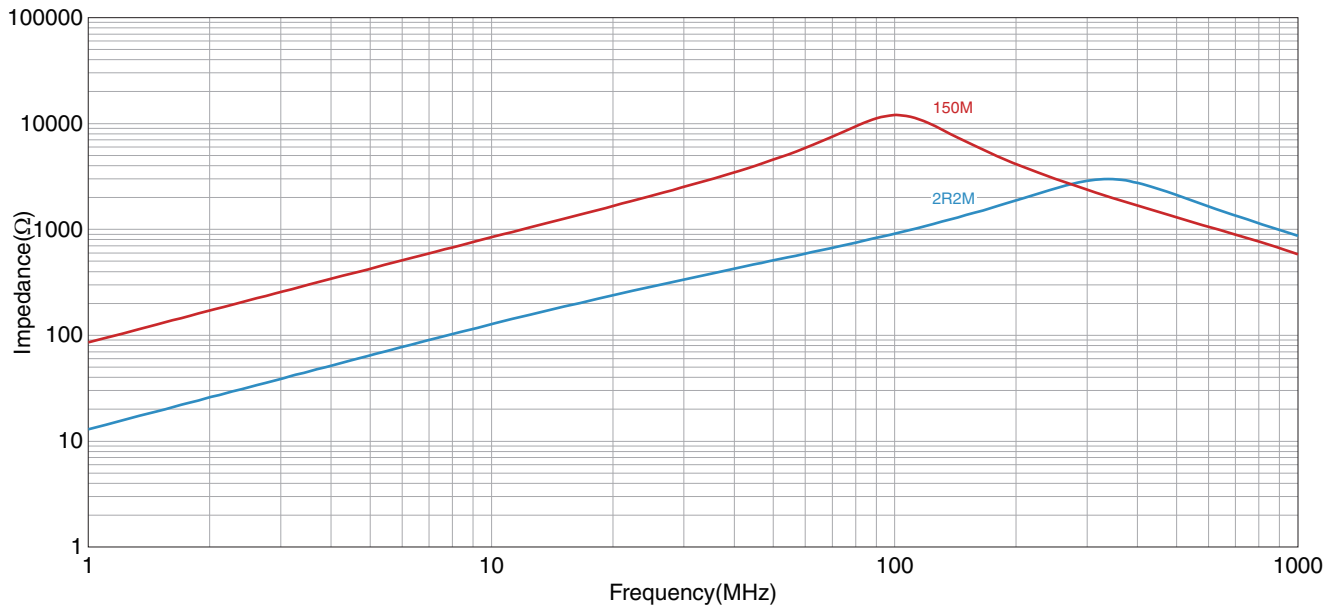

■ INDUCTANCE VS. DC BIAS CHARACTERISTICS

□ 105°C

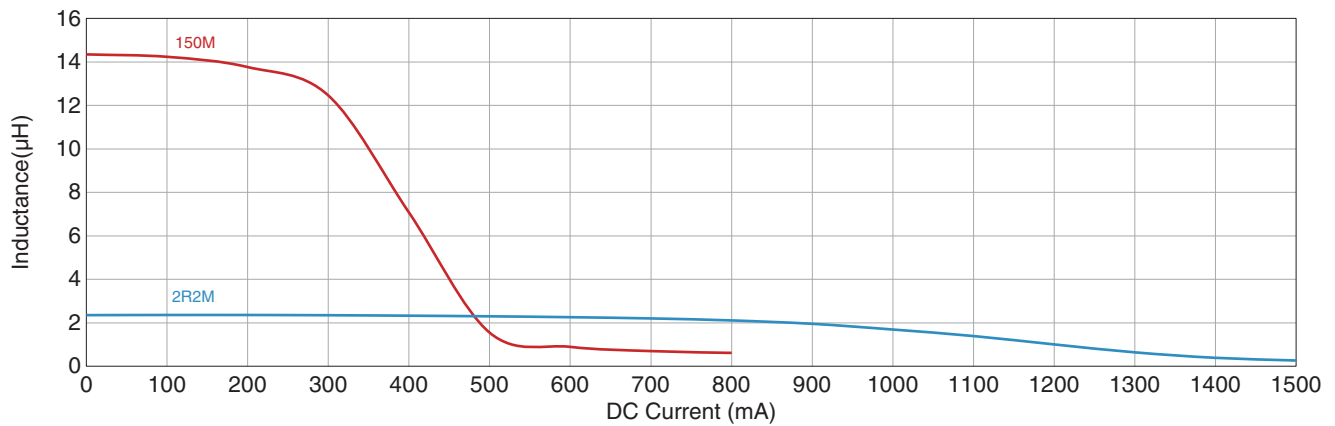

□ 125°C

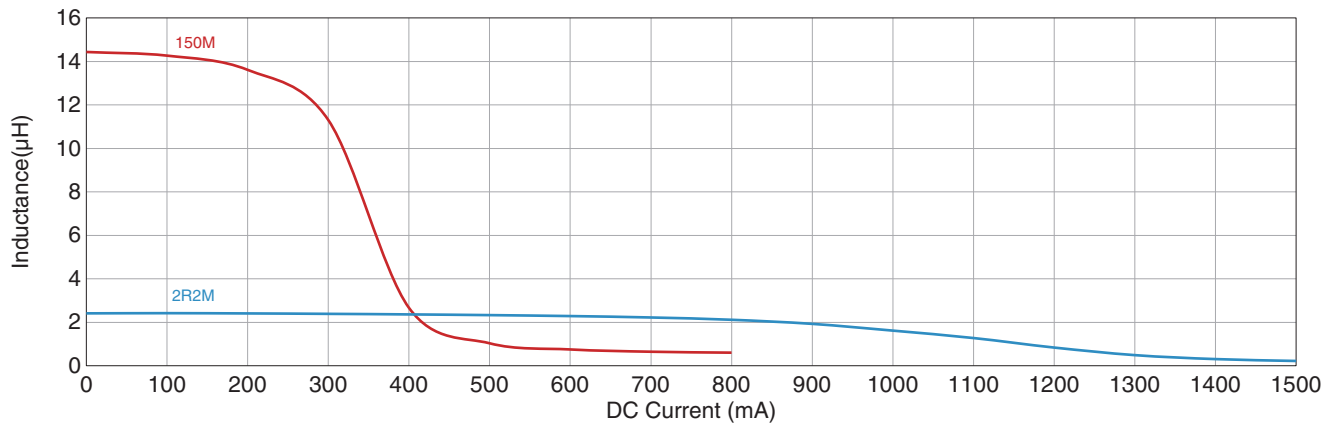

⚠ Please be sure to request delivery specifications that provide further details on the features and specifications of the products for proper and safe use. (2/5)
Please note that the contents may change without any prior notice due to reasons such as upgrading.

ADL3225VM type

SHAPE & DIMENSIONS

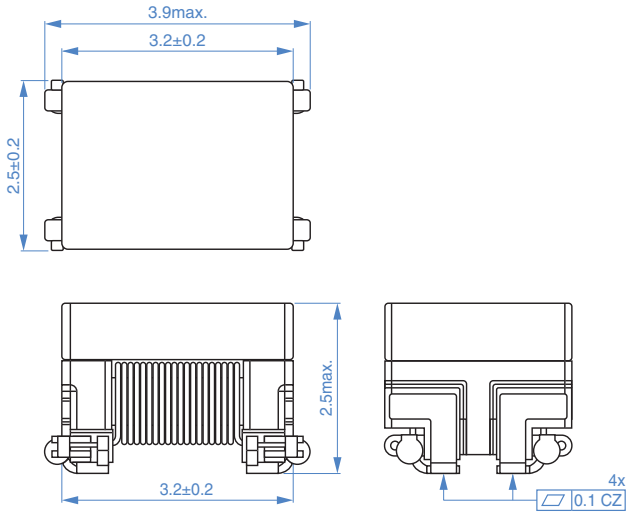

Dimensions in mm

RECOMMENDED LAND PATTERN

ADL3225VM-2R2M-TL000

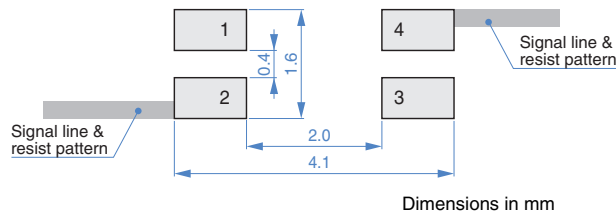
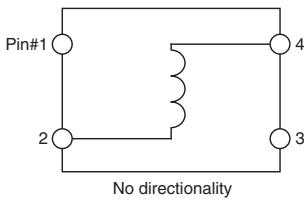

ADL3225VM-150M-TL000

ADL3225VM-150M has 4 terminals, but please connect it in a short-circuited state in the width direction and use it as a 2-terminal component. Connect between PIN1-2 and PIN3-4 of the PCB, and cover the pattern that is not used as a footprint with a resist layer. Here is an example of a footprint connection.

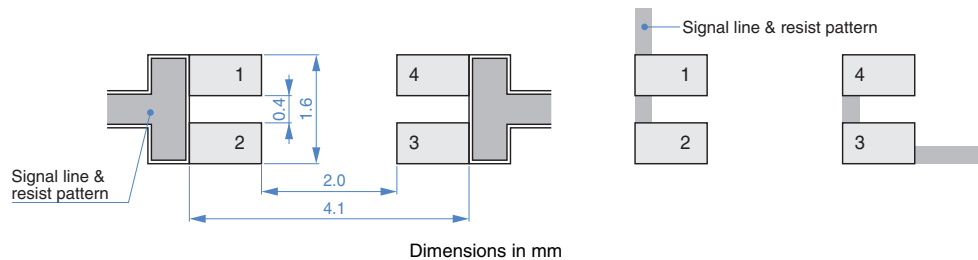
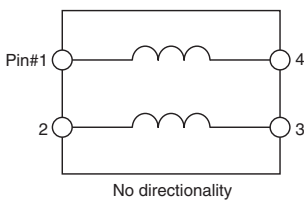

ADL3225VM type

RECOMMENDED REFLOW PROFILE

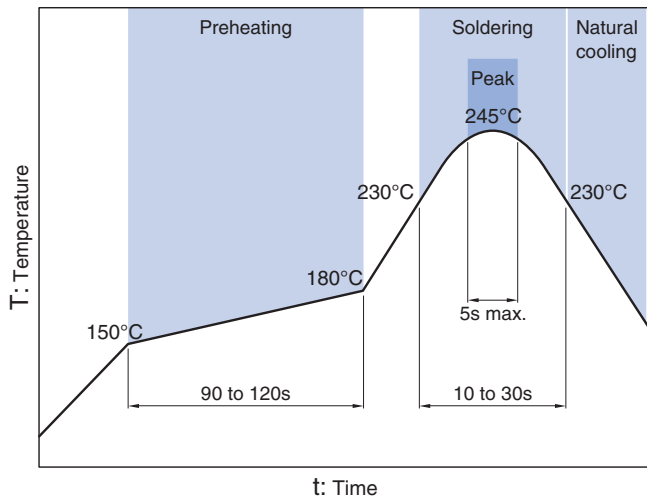

TEMPERATURE RANGE, INDIVIDUAL WEIGHT

Operating temperature range*	Storage temperature range	Individual weight
-55 to +155 °C	-55 to +155 °C	0.076 g

* Operating temperature range includes self-temperature rise.

PACKAGING STYLE

REEL DIMENSIONS

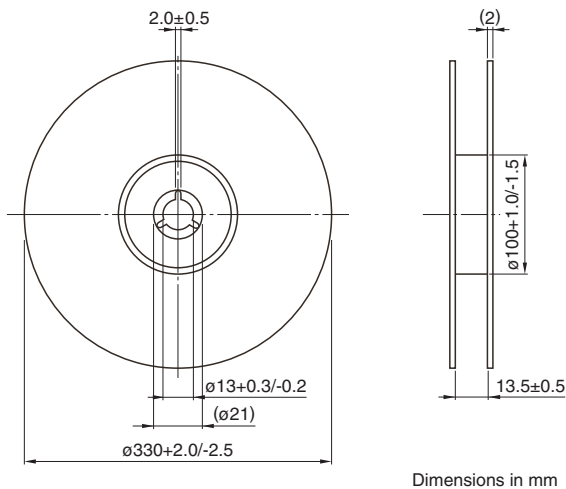

TAPE DIMENSIONS

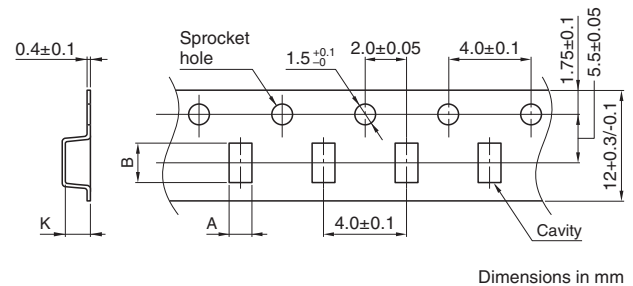

Type	A	B	K
ADL3225VM	(2.85)	(4.2)	(2.7)

PACKAGE QUANTITY

Package quantity	6000 pcs/reel
------------------	---------------

REMINDERS FOR USING THESE PRODUCTS

Before using these products, be sure to request the delivery specifications.

SAFETY REMINDERS

Please pay sufficient attention to the warnings for safe designing when using this products.

REMINDERS

- The storage period is within 6 months. Be sure to follow the storage conditions (temperature: 5 to 40°C, humidity: 10 to 75% RH or less).
If the storage period elapses, the soldering of the terminal electrodes may deteriorate.
- Do not use or store in locations where there are conditions such as gas corrosion (salt, acid, alkali, etc.).
- Before soldering, be sure to preheat components.
The preheating temperature should be set so that the temperature difference between the solder temperature and chip temperature does not exceed 150°C.
- Soldering corrections after mounting should be within the range of the conditions determined in the specifications.
If overheated, a short circuit, performance deterioration, or lifespan shortening may occur.
- When embedding a printed circuit board where a chip is mounted to a set, be sure that residual stress is not given to the chip due to the overall distortion of the printed circuit board and partial distortion such as at screw tightening portions.
- Self heating (temperature increase) occurs when the power is turned ON, so the tolerance should be sufficient for the set thermal design.
- Carefully lay out the coil for the circuit board design of the non-magnetic shield type.
A malfunction may occur due to magnetic interference.
- Use a wrist band to discharge static electricity in your body through the grounding wire.
- Do not expose the products to magnets or magnetic fields.
- Do not use for a purpose outside of the contents regulated in the delivery specifications.
- The products described in this catalog are intended to be installed in automobiles or automotive electronic equipment (AV equipment, telecommunications equipment, home appliances, amusement equipment, computer equipment, personal equipment, office equipment, measurement equipment, industrial robots) and to be used in automobiles (including the case where the said automotive product is mounted in a vehicle) or standard applications as general electronic equipment in automotive applications or standard applications as general electronic equipment in automotive applications in accordance with the scope and conditions described in this specification, while the said automotive or general electronic equipment including the said product is intended to be used in the usual operation and usage methods, respectively. Other than automotive or automotive products are not designed or warranted to meet the requirements of the applications listed below, whose performance and/or quality requires a more stringent level of safety or reliability, or whose failure, malfunction or defect could cause serious damage to society, person or property.
Please understand that we are not responsible for any damage or liability caused by use of the products in any of the applications below or for any other use exceeding the range or conditions set forth in this specification sheet.
If you intend to use the products in the applications listed below or if you have special requirements exceeding the range or conditions set forth in this specification, please contact us.

- (1) Aerospace/aviation equipment
- (2) Transportation equipment (electric trains, ships, etc.)
- (3) Medical equipment
- (4) Power-generation control equipment
- (5) Atomic energy-related equipment
- (6) Seabed equipment
- (7) Transportation control equipment

- (8) Public information-processing equipment
- (9) Military equipment
- (10) Electric heating apparatus, burning equipment
- (11) Disaster prevention/crime prevention equipment
- (12) Safety equipment
- (13) Other applications that are not considered general-purpose applications

When designing your equipment even for general-purpose applications, you are kindly requested to take into consideration securing protection circuit/device or providing backup circuits in your equipment.