

DISPLAY Elektronik GmbH

DATA SHEET

LCD MODULE

DEM 24251 SYH-PY

Product Specification

Version : 0.1.0

10/May/2008

CONTENTS

1.FUNCTIONS & FEATURES2

2. MECHANICAL SPECIFICATIONS.....2

3. BLOCK DIAGRAM.....2

4. EXTERNAL DIMENSIONS.....3

5.PIN ASSIGNMENT3

6. PCB DRAWING AND DESCRIPTION4

7. BACKLIGHT ELECTRICAL/OPTICAL SPECIFCATIONS5

8. DISPLAY DATA RAM (DDRAM)6

9. MAXIMUM ABSOLUTE POWER RATINGS (TA=25°C).....6

10. ELECTRICAL CHARACTERISTICS7

11. CONTROL AND DISPLAY COMMAND.....9

12. STANDARD CHARACTER PATTERN(ST7066U-0A) 10

13. LCD MODULES HANDLING PRECAUTIONS..... 11

14. OTHERS..... 11

1.FUNCTIONS & FEATURES

MODULE NAME	LCD TYPE
DEM 24251 SYH-PY	STN Yellow Green Transflective Positive Mode

- Viewing Direction : 6 o'clock
- Driving Scheme : 1/16 Duty Cycle, 1/5 Bias
- Power Supply Voltage : 5.0 Volt (typ.)
- Backlight : Yellow Green, LED, Lightguide
- V_{LCD} Adjustable For Best Contrast : 4.5 Volt (typ.)
- Display contents : 24 x 2 Characters
- Operation temperature : -20°C to +70°C
- Storage temperature : -25°C to +75°C
- Internal Memory : CGROM (10,080 bits)
: CGRAM (64 x 8 bits)
: DDRAM (80 x 8 bits)
- CGROM : CGROM of the ST7066U
- Interface : Easy Interface with 4-bit or 8-bit MPU

2. MECHANICAL SPECIFICATIONS

- Module Size : 116.00 x 37.00 x 12.00 mm
- Character Pitch : 3.20 x 6.05 mm
- Character Size : 2.70 x 5.55 mm
- Character Font : 5 x 8 dots
- Dot Size : 0.50 x 0.65 mm
- Dot Pitch : 0.55 x 0.70 mm

3. BLOCK DIAGRAM

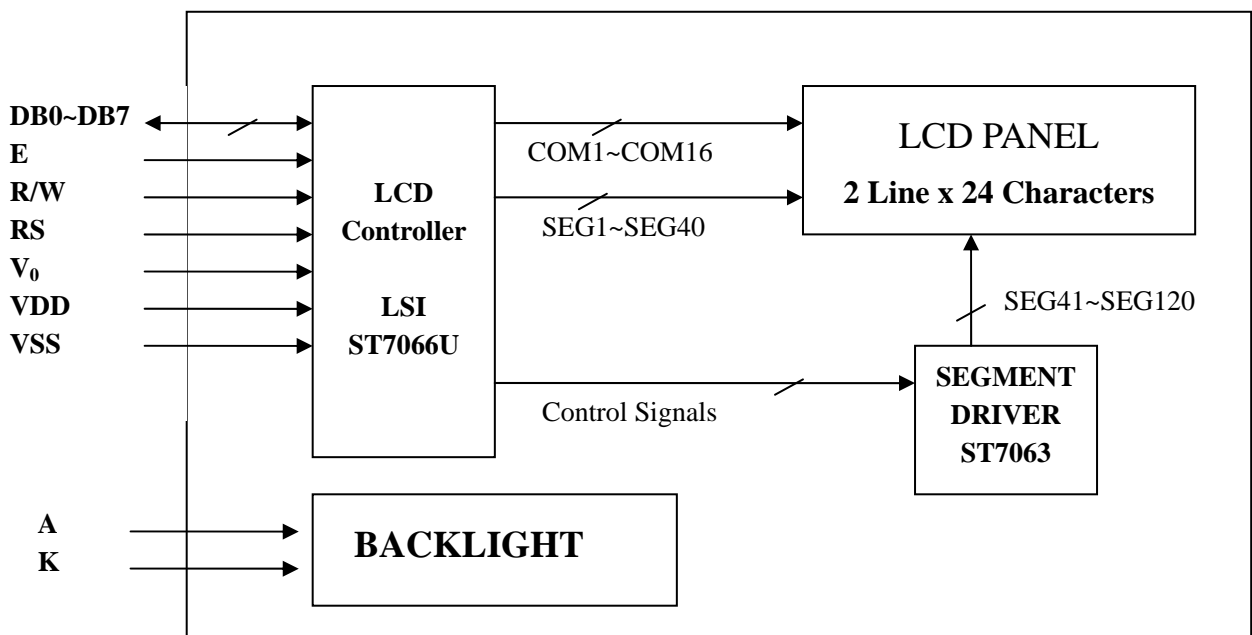

4. EXTERNAL DIMENSIONS

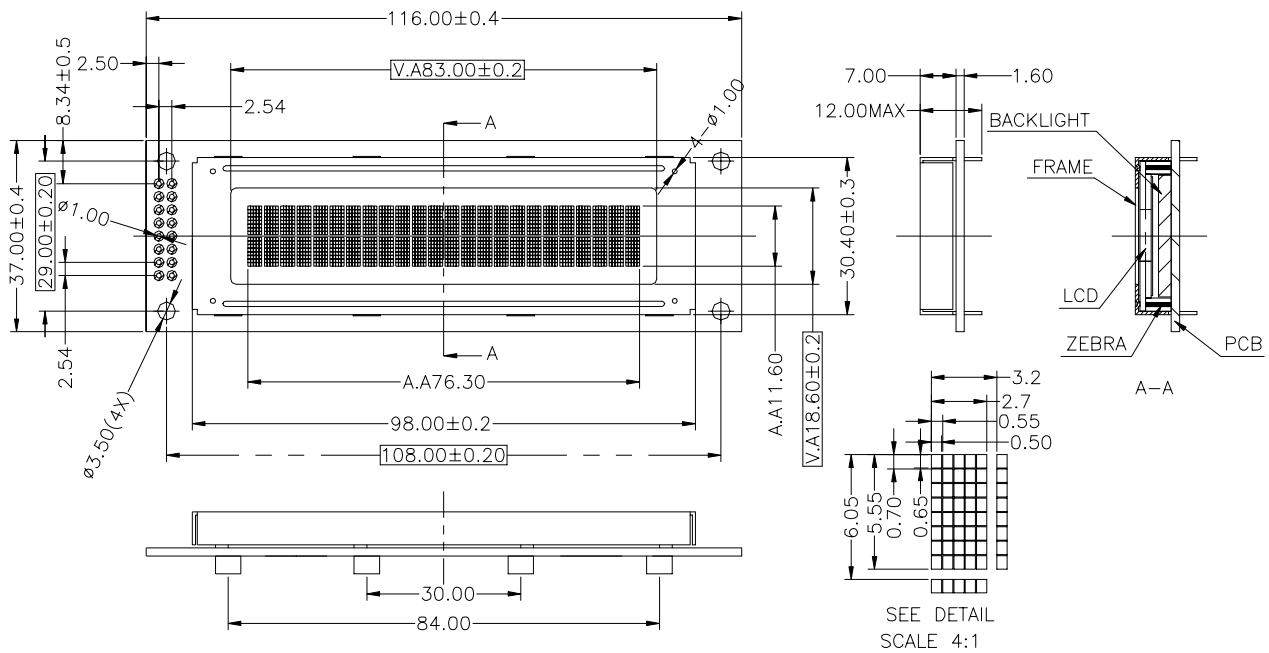

Remarks:
 1.Unmarked tolerance is ±0.3
 2.All material comply with RoHs

5.PIN ASSIGNMENT

Pin No.	Symbol	Function
1	V _{SS}	Ground terminal of module.
2	V _{DD}	Power terminal of module 5.0V.
3	V ₀	Power Supply for liquid crystal drive.
4	RS	Register select RS = 0...Instruction register RS = 1...Data register
5	R/W	Read /Write R/W = 1...Read R/W = 0...Write
6	E	Read/Write Enable Signal
7	DB0	Bi-directional data bus, data transfer is performed once, thru DB0 to DB7, in the case of interface data. Length is 8-bits; and twice, thru DB4 to DB7 in the case of interface data length is 4-bits. Upper four bits first then lower four bits.
8	DB1	
9	DB2	
10	DB3	
11	DB4	
12	DB5	
13	DB6	
14	DB7	
15	LED – (K)	Please also refer to 6.1 PCB drawing and description.
16	LED + (A)	Please also refer to 6.1 PCB drawing and description.

6. PCB DRAWING AND DESCRIPTION

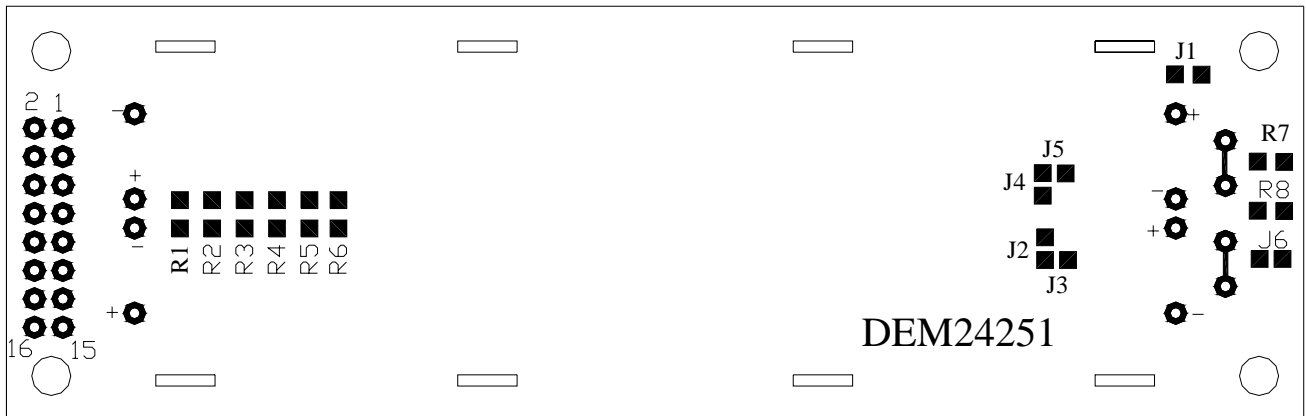

Note: The part no. DEM24251 is printed on the PCB

DESCRIPTION:

6-1-1. The polarity of the pin 15 and the pin 16

LED Polarity(1)	
15 Pin	16Pin
Anode	Cathode
J3=J5=open J2=J4=closed	

LED Polarity(2)	
15 Pin	16 Pin
Cathode	Anode
J3=J5= closed J2=J4= open	

Note: In application module, J2=J4= open and J3=J5=closed

6-1-2. The metal-bezel should be on ground when the J1 is solder-Bridge.

Note: In application module, J1=closed

6-1-3. The LED resistor should be bridged when the J6 is solder-Bridge.

Note: In application module, J6=open

6-1-4. The R7 and the R8 are the LED resistor.

Note: In application module, R7=10 Ohm.

7. BACKLIGHT ELECTRICAL/OPTICAL SPECIFICATIONS

7.1 Electrical-Optical Characteristics

	SYMBOL	MIN.	TYP.	MAX.	UNIT	CONDITIONS
Forward Voltage	V _f		4.1	4.6	V	If=10*4 mA
Forward Current	I _f		10*4	20*4	mA	
Power Disdipation	P _d		0.17		W	If=10*4 mA
Reverse Voltage	V _R		10.0		V	
Reverse Current	I _R		0.200		mA	
Luminous Intensity	I _v	25	30	50	cd/m ²	If=10*4 mA
Emission Wavelength	λ _P		572		nm	I _f = 10 mA T _a = 25°C

7.2 BACKLIGHT DRAWING

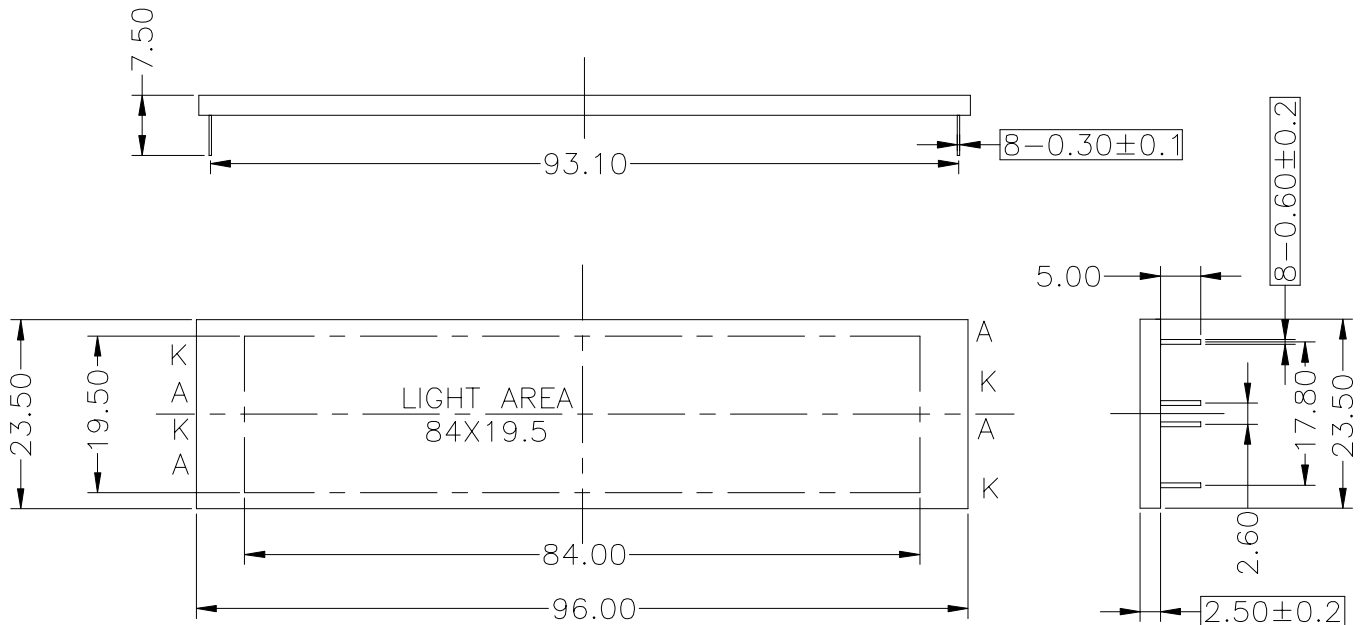

Remarks:
 1.Color:yellow green
 2.Unmarked tolerance is ±0.30
 3.All materials comply with RoHs

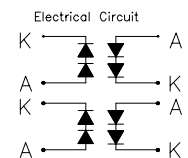

8. DISPLAY DATA RAM (DDRAM)

	1	2	...	10	11	12	13	14	15	16	17	18	...	24	← DISPLAY POSITION
FIRST LINE	00	01	...	09	0A	0B	0C	0D	0E	0F	10	11	...	17	← DDRAM ADDRESS
SECOND LINE	40	41	...	49	4A	4B	4C	4D	4E	4F	50	51	...	57	

9. MAXIMUM ABSOLUTE POWER RATINGS (Ta=25°C)

Item	Symbol	Standard value	Unit
Power supply voltage (1)	V_{DD}	-0.3~+7.0	V
Power supply voltage (2)	V_0	$V_{DD}-15.0\sim V_{DD}+0.3$	V
Input voltage	V_{IN}	-0.3~ $V_{DD}+0.3$	V
Operating temperature	T_{opr}	-20~+70	°C
Storage temperature	T_{stg}	-25~+75	°C

10. ELECTRICAL CHARACTERISTICS

10-1 DC Characteristics ($V_{DD}=4.5V\sim 5.5V$, $T_a=-20\sim +70^{\circ}C$)

Item	Symbol	Standard Value			Test Condition	Unit
		MIN	TYP	MAX		
Operating Voltage	V_{DD}	4.5	5	5.5	-----	V
Supply Current	I_{DD}	----	0.35	0.6	$V_{DD}=5V, f_{osc}=270kHz$	mA
LCD Driving Voltage	V_{LCD}	3.0	---	13.0	$V_{DD}-V_5$ (1/5, 1/4 Bias)	V

10-2 AC Characteristics ($V_{DD}=4.5V\sim 5.5V$, $T_a=-20\sim +70^{\circ}C$)

10-2-1 Write mode (writing data from MPU to ST7066)

Characteristic	Symbol	Min	Type	Max	Unit	Test PIN
E Cycle Time	t_C	1200	---	---	ns	E
E Rise Time	t_R	---	---	25	ns	E
E Fall Time	t_F	---	---	25	ns	E
E Pulse width (High, Low)	t_W	140	---	---	ns	E
R/W and RS Set-up Time	t_{SU1}	0	---	---	ns	R/W,RS
R/W and RS Hold Time	t_{H1}	10	---	---	ns	R/W,RS
Data Set-up Time	t_{SU2}	40	---	---	ns	DB0~DB7
Data Hold Time	t_{H2}	10	---	---	ns	DB0~DB7

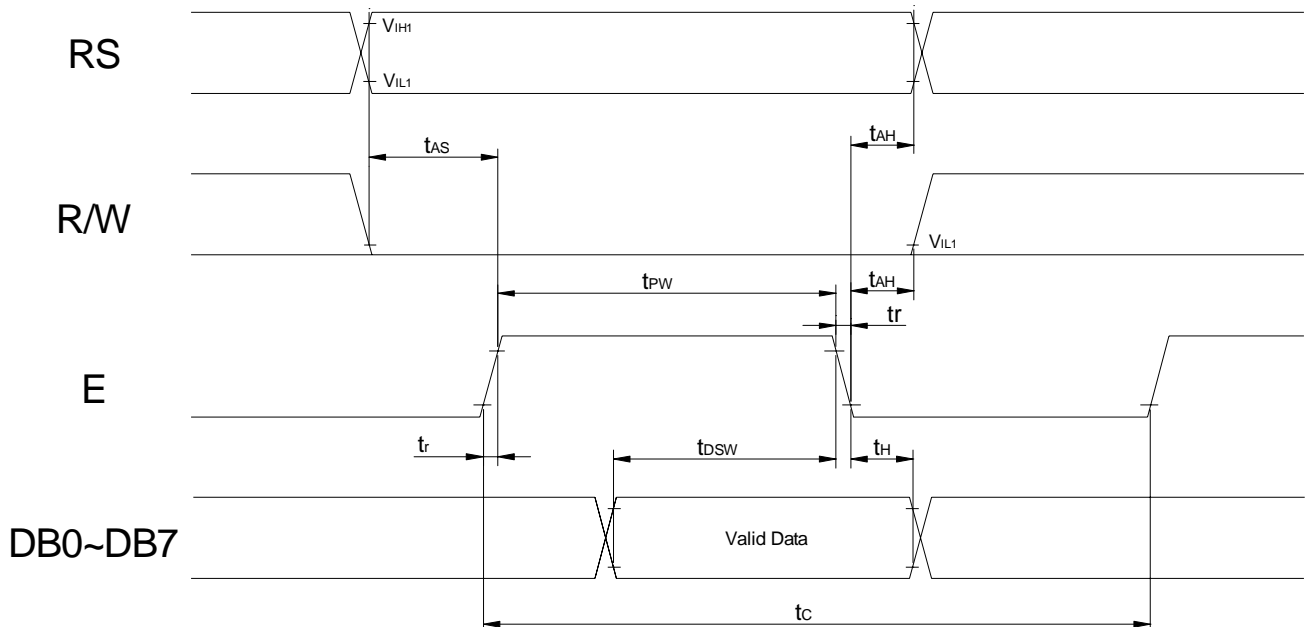

10-2-2 Read mode (reading data from ST7066 to MPU)

Characteristic	Symbol	Min	Type	Max	Unit	Test PIN
E Cycle Time	t_C	1200	---	---	ns	E
E Rise Time	t_R	---	---	25	ns	E
E Fall Time	t_F	---	---	25	ns	E
E Pulse width (High, Low)	t_W	140	---	---	ns	E
R/W and RS Set-up Time	t_{SU}	0	---	---	ns	R/W,RS
R/W and RS Hold Time	t_H	10	---	---	ns	R/W,RS
Data Output Delay Time	t_D	---	---	100	ns	DB0~DB7
Data Hold Time	t_{DH}	10	---	---	ns	DB0~DB7

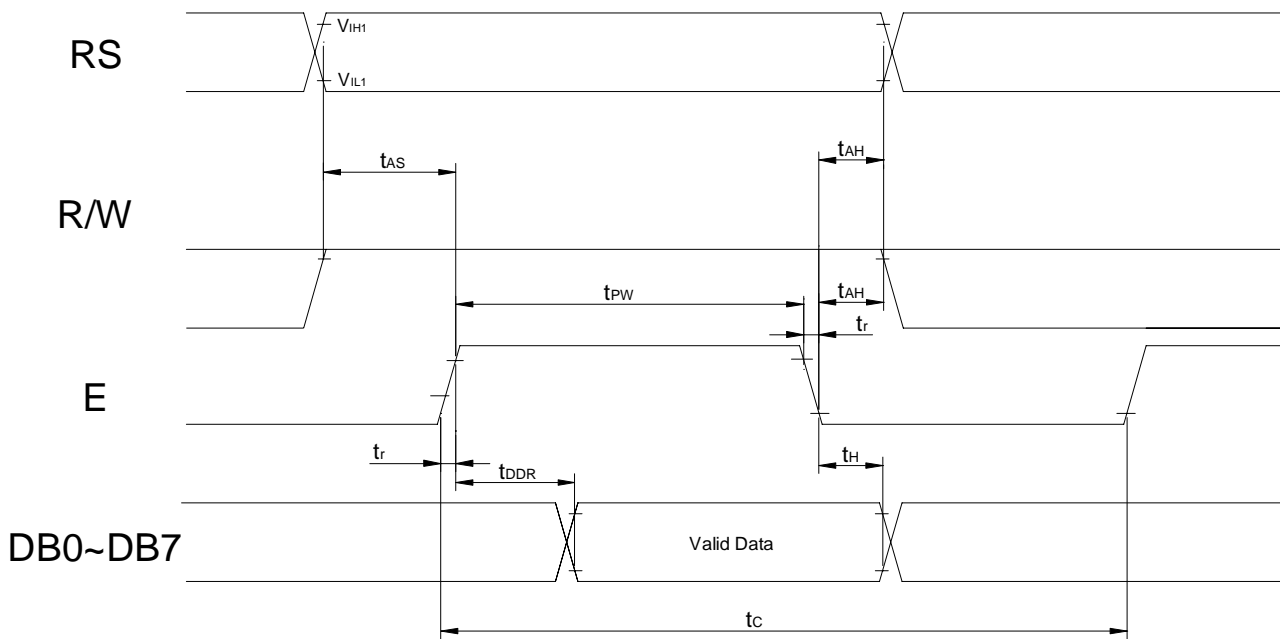

11. CONTROL AND DISPLAY COMMAND

Command	RS	R/W	DB7	DB6	DB5	DB4	DB3	DB2	DB1	DB0	Execution time (fosc=270KHz)	Remark
Clear Display	0	0	0	0	0	0	0	0	0	1	1.52ms	Write"20H" to DDRAM. And set DDRAM address to "00H" from AC
Return home	0	0	0	0	0	0	0	0	1	x	1.52ms	Set DDRAM address to "00H" from AC and return cursor to its original position if shifted. The contents of DDRAM are not changed.
Entry mode Set	0	0	0	0	0	0	0	1	I/D	S	37us	Sets cursor move direction and specifies display shift. These operations are performed during data write and read.
Display on/off control	0	0	0	0	0	0	1	D	C	B	37us	D=1: entire display on C=1: cursor on B=1: cursor position on
Cursor or Display Shift	0	0	0	0	0	1	S/C	R/L	x	x	37us	Set cursor moving and display shift control bit, and the direction, without changing DDRAM data.
function Set	0	0	0	0	1	DL	N	F	x	x	37us	DL: interface data is 8/4 bits N: number of line is 2/1 F: font size is 5x11/5x8
Set CGRAM address	0	0	0	1	AC5	AC4	AC3	AC2	AC1	AC0	37us	Set CGRAM address in address counter
Set DDRAM address	0	0	1	AC6	AC5	AC4	AC3	AC2	AC1	AC0	37us	Set DDRAM address in address counter
Read busy flag& address	0	1	BF	AC6	AC5	AC4	AC3	AC2	AC1	AC0	0us	Whether during internal operation or not can be known by reading BF. The contents of address counter can also be read.
Write data to RAM	1	0	D7	D6	D5	D4	D3	D2	D1	D0	37us	Write data into internal RAM (DDRAM/CGRAM)
Read data from RAM	1	1	D7	D6	D5	D4	D3	D2	D1	D0	37us	Read data from internal RAM (DDRAM / CGRAM)

Note:

Be sure the ST7066U is not in the busy state (BF=00 before sending an instruction from the MPU to the ST7066U. If an instruction is sent without checking the busy flag, the time between the first instruction and next instruction will take much longer than the instruction time itself. Refer to instruction table for the list of each instruction execution time.

12. STANDARD CHARACTER PATTERN (ST7066U-0A)

High 4bit Low 4bit	0000	0001	0010	0011	0100	0101	0110	0111	1000	1001	10010	1011	1100	1101	1110	1111
0000	CGRAM (1)			0	1	2	3	4				5	6	7	8	9
0001	(2)		!	1	A	a	2	3			4	5	6	7	8	9
0010	(3)		"	2	B	b	3	4			5	6	7	8	9	0
0011	(4)		*	3	C	c	4	5			6	7	8	9	0	1
0100	(5)		*	4	D	d	5	6			7	8	9	0	1	2
0101	(6)		*	5	E	e	6	7			8	9	0	1	2	3
0110	(7)		*	6	F	f	7	8			9	0	1	2	3	4
0111	(8)		*	7	G	g	8	9			0	1	2	3	4	5
1000	(1)		C	H	X	h	x				0	1	2	3	4	5
1001	(2)		>	9	I	Y	i	y			6	7	8	9	0	1
1010	(3)		*	*	J	Z	j	z			7	8	9	0	1	2
1011	(4)		+	*	K	E	k	e			8	9	0	1	2	3
1100	(5)		.	<	L	* I	l	l			9	0	1	2	3	4
1101	(6)		—	—	M	J	m	j			0	1	2	3	4	5
1110	(7)		.	>	N	* n	n	* n			1	2	3	4	5	6
1111	(8)		/	?	O	—	o	*			2	3	4	5	6	7

13. LCD MODULES HANDLING PRECAUTIONS

- Please remove the protection foil of polarizer before using.
- The display panel is made of glass. Do not subject it to a mechanical shock by dropping it from a high place, etc.
- If the display panel is damaged and the liquid crystal substance inside it leaks out, do not get any in your mouth. If the substance come into contact with your skin or clothes promptly wash it off using soap and water.
- Do not apply excessive force to the display surface or the adjoining areas since this may cause the color tone to vary.
- The polarizer covering the display surface of the LCD module is soft and easily scratched. Handle this polarize carefully.
- To prevent destruction of the elements by static electricity, be careful to maintain an optimum work environment.
 - Be sure to ground the body when handling the LCD module.
 - Tools required for assembly, such as soldering irons, must be properly grounded.
 - To reduce the amount of static electricity generated, do not conduct assembly and other work under dry conditions.
 - The LCD module is coated with a film to protect the display surface. Exercise care when peeling off this protective film since static electricity may be generated.
- Storage precautions
When storing the LCD modules, avoid exposure to direct sunlight or to the light of fluorescent lamps. Keep the modules in bags designed to prevent static electricity charging under low temperature / normal humidity conditions (avoid high temperature / high humidity and low temperatures below 0°C). Whenever possible, the LCD modules should be stored in the same conditions in which they were shipped from our company.

14. OTHERS

- Liquid crystals solidify at low temperature (below the storage temperature range) leading to defective orientation of liquid crystal or the generation of air bubbles (black or white). Air bubbles may also be generated if the module is subjected to a strong shock at a low temperature.
- If the LCD modules have been operating for a long time showing the same display patterns may remain on the screen as ghost images and a slight contrast irregularity may also appear. Abnormal operating status can be resumed to be normal condition by suspending use for some time. It should be noted that this phenomena does not adversely affect performance reliability.
- To minimize the performance degradation of the LCD modules resulting from caused by static electricity, etc. exercise care to avoid holding the following sections when handling the modules:
 - Exposed area of the printed circuit board
 - Terminal electrode sections