

ISS.	AMEND	DATE
1	ISSUED	22/01/18

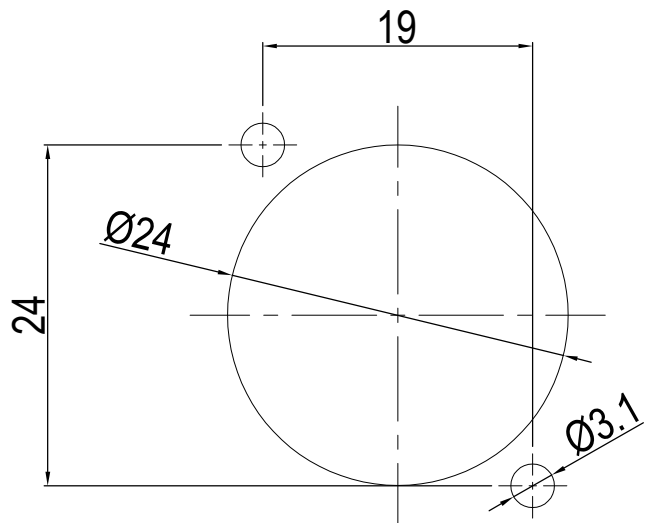

Panel cut out (front view)

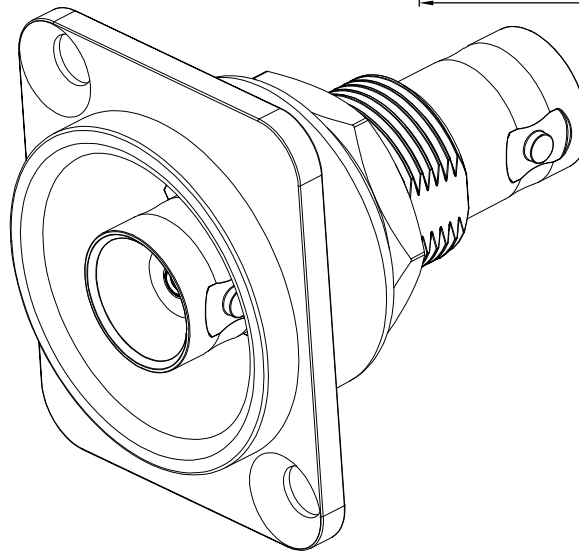
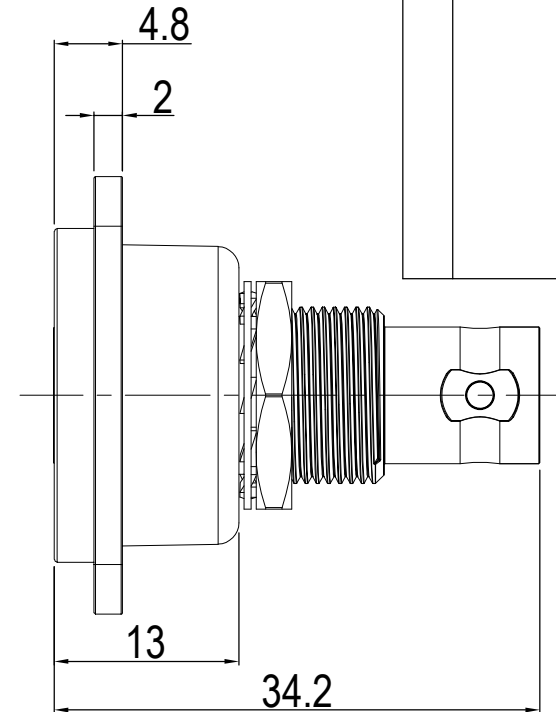
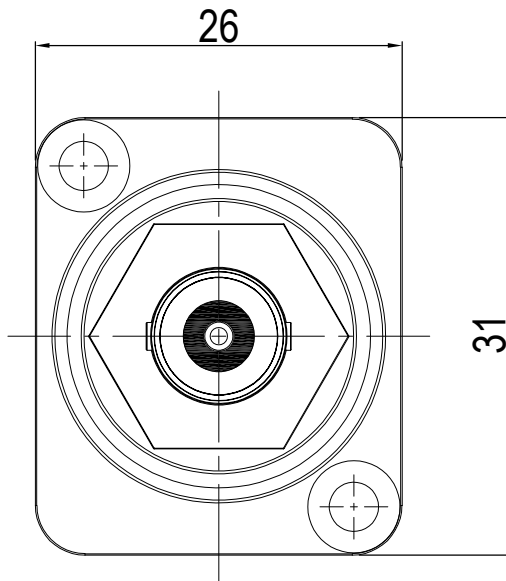

ITEM	DESCRIPTION	MATERIAL	FINISH
1	FRAME	ZINC DIECAST	BLACK
2	NUT	BRASS	NICKEL
3	WASHER	BRASS	NICKEL
4	BNC	ALLOY	NICKEL

RoHS
COMPLIANT

TOLERANCE
 NO DEC. PLACE ±
 1 DEC. PLACE ±
 2 DEC. PLACE ±
 HOLE Ø ±
 ANGLES ±
 UNLESS OTHERWISE STATED

DO NOT SCALE

Cliff Electronic Components Ltd.

76 Holmethorpe Avenue, Holmethorpe Industrial Estate,
 Redhill, Surrey, RH1 2PF, England, UK
 Tel: 01737-771375 Fax: 01737-766012 Website: www.cliffuk.co.uk

DIMENSIONS IN MILLIMETERS UNLESS OTHERWISE STATED. WORK TO DIMENSIONS. REMOVE ALL BURRS. IF IN DOUBT ASK.

3rd ANGLE PROJECTION:

MATERIAL: SEE TABLE

FINISH: SEE TABLE

TITLE: XLR BNC 50Ω FT - BLACK METAL

THE CONTENTS OF THIS DOCUMENT MUST NOT BE COPIED OR DISCLOSED TO A 3rd PARTY WITHOUT WRITTEN PERMISSION OF CLIFF UK. © 2018

DRAWN: T.J.O.

APPROVED: D.P.J.

DRWG. No. **CP30120**

FORM: A4DRWGI