

# DI5029

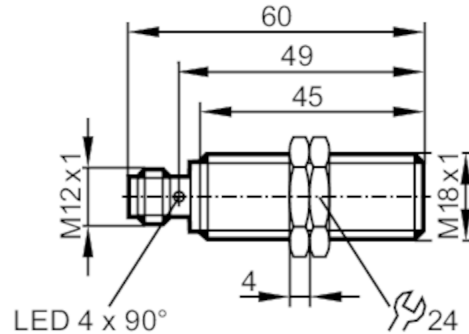

## Compact evaluation unit for speed monitoring

DGK3007BWRKG/IO/US



### Product characteristics

Electrical design	PNP/NPN
Output function	normally open / normally closed; (parameterisable)
Sensing range [mm]	7
Communication interface	IO-Link
Housing	threaded type
Dimensions [mm]	M18 x 1 / L = 60

### Application

Application	simple evaluation of rotating and linear movement with regard to underspeed; blocking
-------------	---

### Electrical data

Nominal voltage DC [V]	10...30
Current consumption [mA]	< 10
Protection class	III
Reverse polarity protection	yes

### Outputs

Electrical design	PNP/NPN
Output function	normally open / normally closed; (parameterisable)
Max. voltage drop switching output DC [V]	2.5
Permanent current rating of switching output DC [mA]	100
Short-circuit proof	yes
Overload protection	yes

### Detection zone

Sensing range [mm]	7
Sensing range adjustable	no
Operating distance [mm]	0...5.67

### Measuring/setting range

Setting range [Imp/min]	5...24000
-------------------------	-----------

### Accuracy / deviations

Correction factor	steel: 1 / stainless steel: 0.7 / brass: 0.5 / aluminium: 0.4 / copper: 0.3
Hysteresis [% of Sr]	10

# DI5029



## Compact evaluation unit for speed monitoring

DGK3007BWRKG/IO/US

Response times		
Start-up delay	[s]	0...30; (In steps of: 100 ms; Default: 15 s)
Max. damping frequency	[Imp/min]	30000
Interfaces		
Communication interface		IO-Link
Operating conditions		
Ambient temperature	[°C]	-40...85
Storage temperature	[°C]	-25...85
Protection		IP 66; IP 67; IP 68; IP 69K
Tests / approvals		
EMC	EN 61000-4-2 ESD	4 kV CD / 8 kV AD
	EN 61000-4-3 HF radiated	10 V/m
	EN 61000-4-4 Burst	2 kV
	EN 61000-4-6 HF conducted	10 V
	EN 55011	class B
	EN 60947-5-2	
Shock resistance	EN 60068-2-27 Ea	100 g 11 ms half-sine; 3 shocks each in every direction of the 3 coordinate axes
Vibration resistance	DIN EN 60947-5-2	20 g (10...3000 Hz)
		50 sweep cycles per frequency; 1 octave per minute in 3 axes
MTTF	[years]	672
UL approval	UL Approval no.	A008
Mechanical data		
Weight	[g]	47.9
Housing		threaded type
Mounting		flush mountable
Dimensions	[mm]	M18 x 1 / L = 60
Thread designation		M18 x 1
Materials		brass white bronze coated; sensing face: PBT orange; LED window: PEI; lock nuts: brass white bronze coated
Tightening torque	[Nm]	25
Displays / operating elements		
Display	SIO mode	
	output stage supplied with current	4 x LED, yellow
	IO-Link mode	
	target in measuring range	4 x LED, yellow
	target outside measuring range	4 x LED, yellow flashing
Accessories		
Accessories (supplied)		lock nuts: 2
Electrical connection		
Connector: 1 x M12		

# DI5029



## Compact evaluation unit for speed monitoring

DGK3007BWRKG/IO/US



### Connection

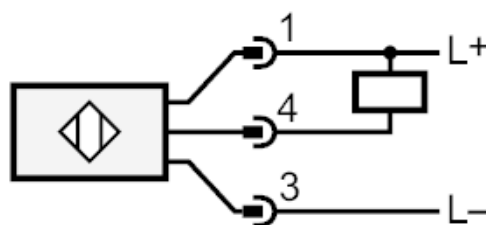
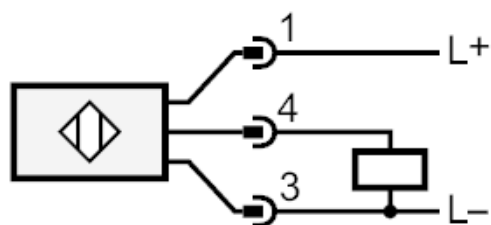

4: OUT / IO-Link