

Screening Grid Retainer for MLSL

ZLSS002

Part Number



Technical Data

Mechanical Data

Material	Aluminum
Weight	65 g
Packaging unit	1 Piece

Complementary Products

ZLSE005, ZLSE006 Protective Screen

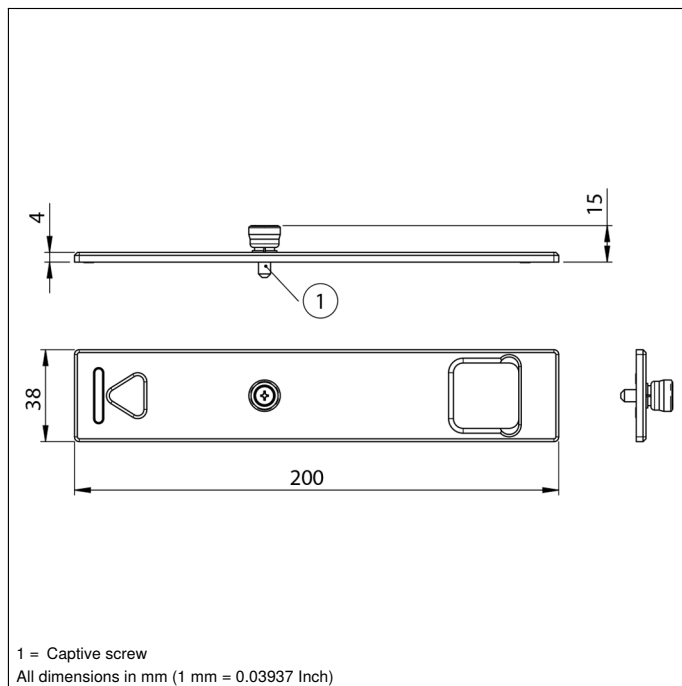

Protective discs must be ordered separately (not included in scope of delivery)