

Stopki wahliwe – stal, forma B

Opis artykułu/ilustracje produktu



Opis

Materiał:

Stopka poziomująca, trzpień gwintowany ze stali.
Podkładka antypoślizgowa (NBR) 70 w skali Shore'a.

Wersja:

Stopka poziomująca lakierowana na żółto. Trzpień gwintowany ocynkowany.
Podkładka antypoślizgowa, czarna.

Wskazówka:

Wysokoobciążalne stopki wahliwe ze stali ze stopką lakierowaną na żółto, opcjonalnie z podkładką antypoślizgową. Podkładka antypoślizgowa pochłania wibracje i zabezpiecza przed poślizgiem.

Podane w tabeli wartości obciążenia oparte są na serii eksperymentów. Podane wartości nie uwzględniają oddziałujących promieniowo sił powstających podczas drgań lub innych wstrząsów wpływających na obciążalność.

Dostawa z dopasowaną nakrętką.

Rysunki

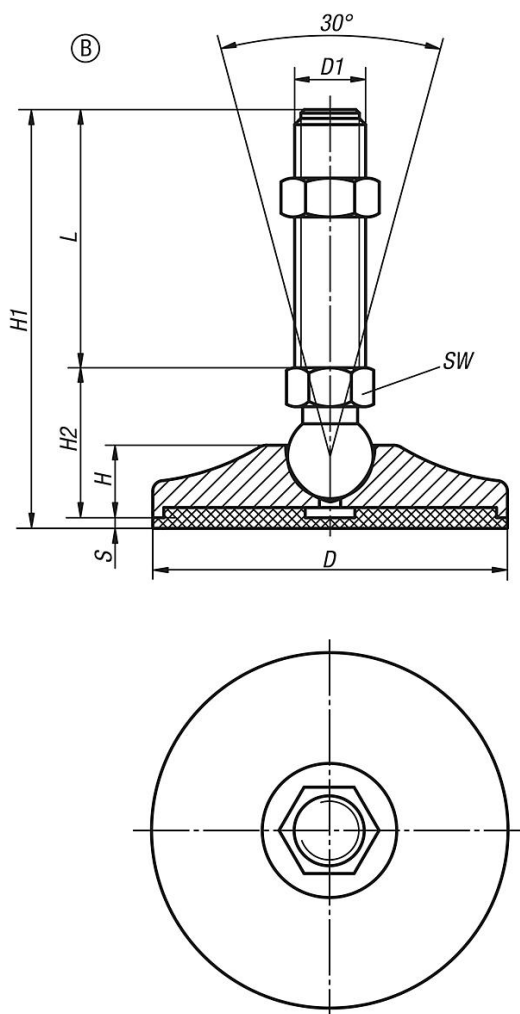

Przegląd artykułów

Nr Zamówienia	Forma	D	D1	H	H1	H2	S	SW	L	Obciążalność maks. kN (tylko przy obciążeniu statycznym)
K0742.105010X25	B	50	M10	16	56	28	3	14	25	15
K0742.105010X50	B	50	M10	16	81	28	3	14	50	15
K0742.105010X75	B	50	M10	16	106	28	3	14	75	15
K0742.105010X100	B	50	M10	16	131	28	3	14	100	15
K0742.105010X125	B	50	M10	16	156	28	3	14	125	15
K0742.105012X25	B	50	M12	16	56	28	3	14	25	15
K0742.105012X50	B	50	M12	16	81	28	3	14	50	15
K0742.105012X75	B	50	M12	16	106	28	3	14	75	15
K0742.105012X100	B	50	M12	16	131	28	3	14	100	15
K0742.105012X125	B	50	M12	16	156	28	3	14	125	15
K0742.105014X25	B	50	M14	16	56	28	3	14	25	15
K0742.105014X50	B	50	M14	16	81	28	3	14	50	15
K0742.105014X75	B	50	M14	16	106	28	3	14	75	15
K0742.105014X100	B	50	M14	16	131	28	3	14	100	15
K0742.105014X125	B	50	M14	16	156	28	3	14	125	15
K0742.106514X50	B	65	M14	17	83	30	3	14	50	20
K0742.106514X75	B	65	M14	17	108	30	3	14	75	20
K0742.106514X100	B	65	M14	17	133	30	3	14	100	20
K0742.106514X125	B	65	M14	17	158	30	3	14	125	20
K0742.106514X150	B	65	M14	17	183	30	3	14	150	20
K0742.106516X50	B	65	M16	17	83	30	3	16	50	20

Stopki wahlwe – stal, forma B

Przegląd artykułów

Nr Zamówienia	Forma	D	D1	H	H1	H2	S	SW	L	Obciążalność maks. kN (tylko przy obciążeniu statycznym)
K0742.106516X75	B	65	M16	17	108	30	3	16	75	20
K0742.106516X100	B	65	M16	17	133	30	3	16	100	20
K0742.106516X125	B	65	M16	17	158	30	3	16	125	20
K0742.106516X150	B	65	M16	17	183	30	3	16	150	20
K0742.106516X175	B	65	M16	17	208	30	3	16	175	20
K0742.108016X50	B	80	M16	19,5	86	33	3	16	50	30
K0742.108016X75	B	80	M16	19,5	111	33	3	16	75	30
K0742.108016X100	B	80	M16	19,5	136	33	3	16	100	30
K0742.108016X125	B	80	M16	19,5	161	33	3	16	125	30
K0742.108016X150	B	80	M16	19,5	186	33	3	16	150	30
K0742.108016X175	B	80	M16	19,5	211	33	3	16	175	30
K0742.108016X200	B	80	M16	19,5	236	33	3	16	200	30
K0742.108020X75	B	80	M20	19,5	114	36	3	17	75	30
K0742.108020X100	B	80	M20	19,5	139	36	3	17	100	30
K0742.108020X125	B	80	M20	19,5	164	36	3	17	125	30
K0742.108020X150	B	80	M20	19,5	189	36	3	17	150	30
K0742.108020X175	B	80	M20	19,5	214	36	3	17	175	30
K0742.108020X200	B	80	M20	19,5	239	36	3	17	200	30
K0742.110016X50	B	100	M16	20	96	43	3	20	50	35
K0742.110016X75	B	100	M16	20	121	43	3	20	75	35
K0742.110016X100	B	100	M16	20	146	43	3	20	100	35
K0742.110016X125	B	100	M16	20	171	43	3	20	125	35
K0742.110016X150	B	100	M16	20	196	43	3	20	150	35
K0742.110016X175	B	100	M16	20	221	43	3	20	175	35
K0742.110016X200	B	100	M16	20	246	43	3	20	200	35
K0742.110020X75	B	100	M20	20	121	43	3	20	75	45
K0742.110020X100	B	100	M20	20	146	43	3	20	100	45
K0742.110020X125	B	100	M20	20	171	43	3	20	125	45
K0742.110020X150	B	100	M20	20	196	43	3	20	150	45
K0742.110020X175	B	100	M20	20	221	43	3	20	175	45
K0742.110020X200	B	100	M20	20	246	43	3	20	200	45
K0742.110024X75	B	100	M24	20	122	44	3	20	75	55
K0742.110024X100	B	100	M24	20	147	44	3	20	100	55
K0742.110024X125	B	100	M24	20	172	44	3	20	125	55
K0742.110024X150	B	100	M24	20	197	44	3	20	150	55
K0742.110024X175	B	100	M24	20	222	44	3	20	175	55
K0742.110024X200	B	100	M24	20	247	44	3	20	200	55