

Locking Assemblies BAR, Stainless

Material: Stainless steel 1.4401 (AISI 316).

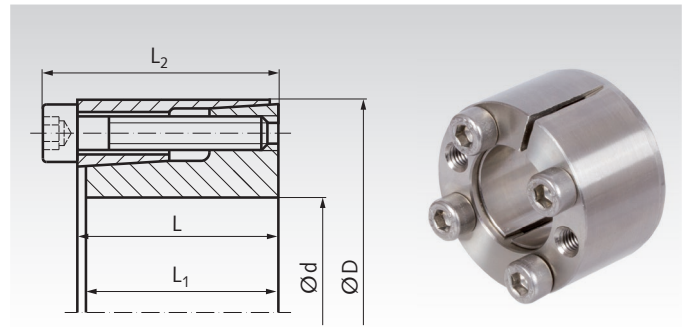

- For fixing a hub (e.g. drive wheel, rotor or similar) on a shaft.
- Stainless Steel.
- For low torques.
- Very good distribution of pressure.
- Very good self-centering.
- Self-releasing at dismounting.
- Also suitable for large hub and shaft tolerances.
- Slight axial offset possible during assembly.



Ordering Details: e.g.: Product No. 615 994 06, Locking Assembly BAR Stainless 6 mm

Product No.	d mm	D mm	L mm	L ₁ mm	L ₂ mm	at T _A transmittable		Surface Pressure		Tensioning Screw A2-70			Weight kg
						T Nm	F _{ax} kN	at Shaft P _w N/mm ²	at Hub P _N N/mm ²	Size DIN 912	T _A Nm	Number	
615 994 06	6	16	11	10,5	13,5	3	0,9	49	19	M2,5 x 10	0,5	3	0,012
615 994 07	7	17	11	10,5	13,5	3	0,9	42	17	M2,5 x 10	0,5	3	0,013
615 994 08	8	18	11	10,5	13,5	4	0,9	37	17	M2,5 x 10	0,5	3	0,015
615 994 09	9	20	13	12,5	15,5	6	1,2	37	17	M2,5 x 12	0,5	4	0,020
615 994 10	10	20	13	12,5	15,5	6	1,2	33	17	M2,5 x 12	0,5	4	0,019
615 994 11	11	22	13	12,5	15,5	7	1,2	30	15	M2,5 x 12	0,5	4	0,024
615 994 12	12	22	13	12,5	15,5	7	1,2	26	15	M2,5 x 12	0,5	4	0,022
615 994 14	14	26	17	16,5	20	13	1,9	28	15	M3 x 16	0,9	4	0,039
615 994 15	15	28	17	16,5	20	14	1,9	26	14	M3 x 16	0,9	4	0,044
615 994 16	16	32	17	16,5	21	28	3,5	45	23	M4 x 16	2,2	4	0,066
615 994 17	17	35	21	20,5	25	30	3,5	34	17	M4 x 20	2,2	4	0,092
615 994 18	18	35	21	20,5	25	32	3,5	32	17	M4 x 20	2,2	4	0,087
615 994 19	19	35	21	20,5	25	34	3,5	31	17	M4 x 20	2,2	4	0,084
615 994 20	20	38	21	20,5	26	55	5,5	45	24	M5 x 20	4,2	4	0,100
615 994 22	22	40	21	20,5	26	61	5,5	41	23	M5 x 20	4,2	4	0,110
615 994 24	24	47	26	25	32	96	8,0	44	23	M6 x 25	7,3	4	0,200
615 994 25	25	47	26	25	32	100	8,0	43	23	M6 x 25	7,3	4	0,190
615 994 28	28	50	26	25	32	210	15,0	57	32	M6 x 25	7,3	6	0,220
615 994 30	30	55	26	25	32	220	15,0	54	29	M6 x 25	7,3	6	0,250
615 994 32	32	55	26	25	32	240	15,0	50	29	M6 x 25	7,3	6	0,250
615 994 35	35	60	31	30	37	350	20,0	55	32	M6 x 30	7,3	8	0,360
615 994 38	38	65	31	30	37	380	20,0	51	29	M6 x 30	7,3	8	0,430
615 994 40	40	65	31	30	37	400	20,0	48	29	M6 x 30	7,3	8	0,400
615 994 50	50	80	36	35	44	860	36,0	76	47	M8 x 35	18,0	8	0,700

T = transmittable torque at F_{ax} = 0.

F_{ax} = transmittable axial force at T = 0.

P_w = surface pressure onto the shaft.

P_N = surface pressure onto the hub.

T_A = fastening torque of the screws.

Fit, Surface

Shaft and hub up to tolerance h8/H8.

Surface finish for shaft and hub R_z < 10 µm.

Mounting

The locking assembly has to sit inside the bore by at least the measure „L“. Slightly oil the locking assembly before mounting, do not use molybdenum disulphide or fat. Tighten the screws evenly and crosswise in several steps.

Demounting

Remove all tensioning screws and screw them into the (usually unused) forcing thread of the front ring, until the ring is released.

Hub Calculation and Selection Tool

on the Internet at www.maedler.de

in the section **MÄDLER®-Tools**