



FICHA PRODUCTO/ PRODUCT DATA SHEET

DGI 02.06.02

REF. / SKU

DESCRIPCION / DESCRIPTION

REV

DATE

FS320

FILTRO ARENA / SAND FILTER

0

14/2/19

NEW COLLECTION 2019

CARACTERÍSTICAS / CHARACTERISTICS

CODIGO / EAN13 CODE : 8412081303406

CAUDAL / FLOW RATE: 4 m3/h

MEDIDAS MONTADO / MEASURE: 53 x 41 x 60 cm CR: 84,75 g

SAND CAPACITY: ± 20 kg NO INCLUIDA / NOT INCLUDED

PESO / WEIGHT: 9,250 Kg. - ELECTRIC WEIGHT: 4,330 kg

CONEXIONES / CONECTIONS: Ø 32 / 38 mm

BOMBA / PUMP: 230 V- 50 HZ / 180 W - FIDJI 4

CUBA / TANK: Ø 320 mm

VALVULA 5 VIAS / 5 WAYS VALVE

MANÓMETRO INCLUIDO / MANOMETER INCLUDED



EMBALAJE / PACKAGING

UNIDADES ENVASE / UNITS: 1

MEDIDAS ENVASE / PACKAGE SIZE: 51 X 38 X 59 cm

VOLUMEN ENVASE / PACKAGE VOLUME: 0,114 m³

PESO UNITARIO / UNIT WEIGHT: 10,900 kg

PESO EMBALAJE / BOX PACKAGE WEIGHT: 1,680 kg

ETIQUETA / LABEL



PALETIZADO / PALETS

MEDIDAS PALET / PALET SIZE: 120 X 80 X 15 cm

MEDIDAS TOTAL PALET / TOTAL SIZE PALET: 120 x 80 x 192 cm

VOLUMEN TOTAL PALET / TOTAL VOLUME: 1,27 m³

4 CAJAS POR PLANTA / BOXES X 3 PLANTAS / LAYER

TOTAL EMBALAJES / PACKAGES PALET: 12

TOTAL DE UNIDADES PALET / UNITS PALET: 12

Peso total con palet / Total weight included palet: 150,8 kg

ETIQUETA IDENTIFICACION PALET / PALET LABEL

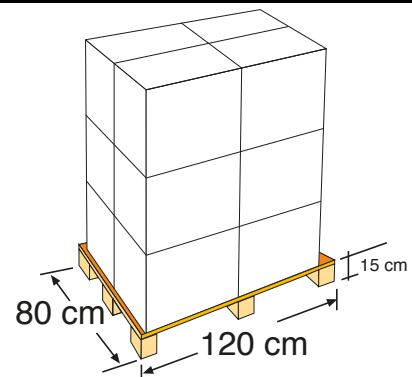

OBSERVACIONES / OBSERVATIONS

FAMILIA: 160 - SUBFAMILIA: 000

ACCORDING TO EUROPEAN NORM EN16713

UNIDAD ECOEMB: CARTON: 2320 g - PLÁSTICO: 38 g