

# ECO.80s+

## Kernboormachine

**EUROBOOR**

FOR PROFESSIONALS BY PROFESSIONALS

### Technische data

	Metrisch	Imperisch
Kernboren	Ø 12 - 80 mm	Ø 1/2" - 3 1/8"
Spiraalboren	Ø 1 - 31,75 mm	Ø 1/16" - 1 1/4"
Verzinken	Ø 10 - 85 mm	Ø 3/8" - 3 3/8"
Lengte	365 mm	14 3/8"
Breedte	310 mm	12 3/16"
Hoogte	510 - 710 mm	20 1/16" - 27 15/16"
Slag	260 mm	10 1/4"
Gewicht*	27,3 kg	60,2 lbs
Magneet (l x b x h)	220 x 110 x 64 mm	8 11/16" x 4 5/16" x 2 1/2"
Magnetische kracht	3.000 kg	6.615 lbs
Motor vermogen	1.700 W	15,4 A
Totaal vermogen	1.800 W	16,4 A
Toerental (onbelast)		(I) 200 tpm (II) 300 tpm (III) 415 tpm (IV) 650 tpm
Toerental (belast 1.700 W, 15,4 A)		(I) 150 tpm (II) 200 tpm (III) 275 tpm (IV) 400 tpm
Opname (Weldon)	MT3 19,05 mm	MT3 3/4"
Krachtvoorziening		110 - 120 V / 60 Hz 220 - 240 V / 50 - 60 Hz

\* Zonder stroomkabel en hendels

### Kenmerken

-  **Oververhittingsbeveiliging**
-  **Overspanningsbeveiliging**
-  **Fluctuatiebeveiliging**
-  **Gyro-Tec**
-  **Automatische uitschakeling**
-  **Olie gesmeerde versnellingsbak**
-  **Koolborstel-slijtage-indicator**
-  **2-weg magneet (TempTec)**
-  **Magneet LED-indicator**

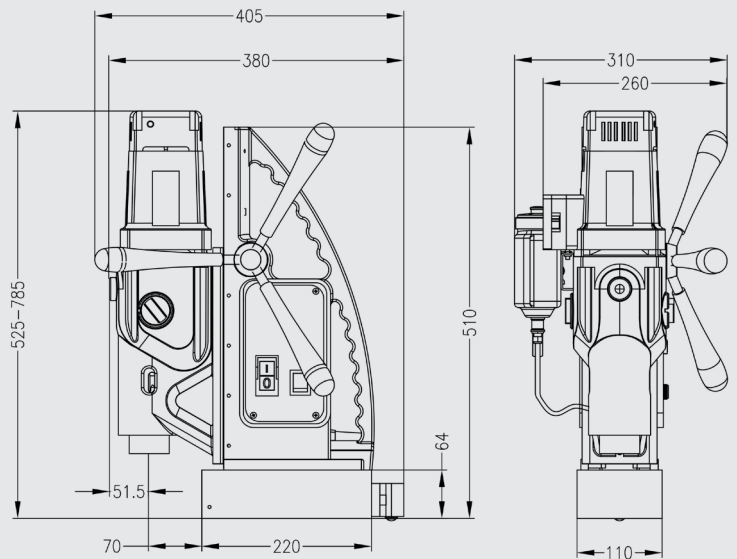

Euroboor stelt alles in het werk om te voldoen aan kwaliteits- en integriteitseisen. Daarom zijn wij als organisatie trots op de erkenning van enkele toonaangevende instanties wereldwijd:



[www.euroboor.com](http://www.euroboor.com)