

1206 F

Engineer's Kit : EK-1206F-X

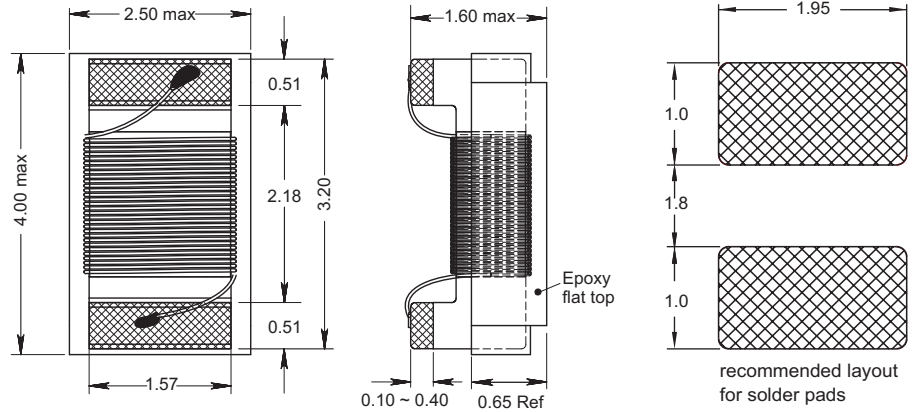
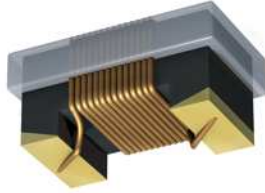

(Wire wound - open)

Chip Inductors for RF Applications

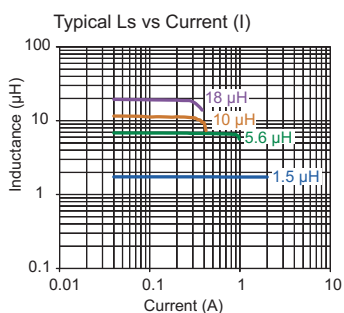
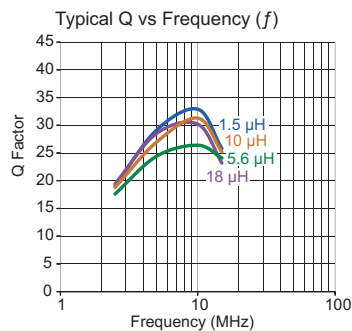
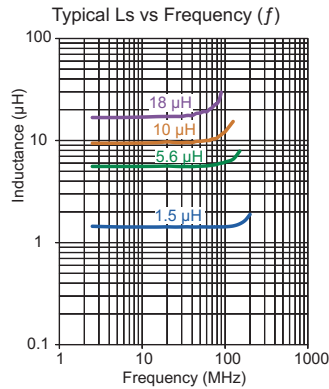
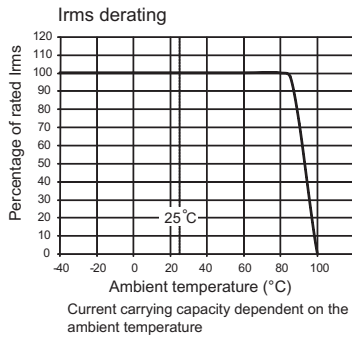

Part No	Inductance	f _L	Tol	Q	f _Q	SRF	DCR	Rated DC
	L (µH)	(MHz)	± (%)	min	(MHz)	(MHz)	max (Ω)	Current (mA)
1206F-1R0K-YY	1.0	7.9	10	25	7.9	300 min	0.98	350
1206F-1R5K-YY	1.5	7.9	10	25	7.9	240 min	1.2	320
1206F-1R8K-YY	1.8	7.9	10	25	7.9	200 min	1.2	320
1206F-2R2K-YY	2.2	7.9	10	25	7.9	200 min	1.3	300
1206F-2R7K-YY	2.7	7.9	10	25	7.9	190 min	1.4	300
1206F-3R3K-YY	3.3	7.9	10	25	7.9	160 min	1.5	280
1206F-3R9K-YY	3.9	7.9	10	25	7.9	160 min	1.9	280
1206F-4R7K-YY	4.7	7.9	10	25	7.9	140 typ	2.2	280
1206F-5R6K-YY	5.6	7.9	10	25	7.9	120 typ	2.4	260
1206F-6R8K-YY	6.8	7.9	10	25	7.9	110 typ	2.8	240
1206F-8R2K-YY	8.2	7.9	10	25	7.9	100 typ	3.1	220
1206F-100K-YY	10	7.9	10	25	7.9	100 typ	4.0	200
1206F-120K-YY	12	7.9	10	18	7.9	90 typ	4.6	200
* 1206F-150K-YY	15	2.5	10	16	2.5	75 typ	8.2	160
* 1206F-180K-YY	18	2.5	10	16	2.5	75 typ	9.0	130
1206F-470K-YY	47	2.5	10	18	2.5	25 typ	11.1	80
* 1206F-101K-YY	100	2.5	10	18	2.5	13 typ	21	80

Single layer (typ)

Core Material : Ferrite

Revision date : 03 Sep 2020

SPQ : Taped / Reel 1000 [-08]
2000 [-01]
7500 [-04]

Remarks: - Unlisted inductance values available upon request.
- 2% and 5% available upon request.
- All are AEC-Q200 Standard approved EXCEPT *