

DANS LE BUT CONSTANT D'AMELIORER SES PRODUITS, Amphenol Socapex SE RESERVE LE DROIT D'EN MODIFIER TOUTE COTE OU CARACTERISTIQUE. IMP 036 A

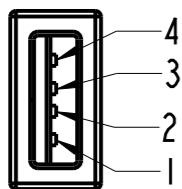
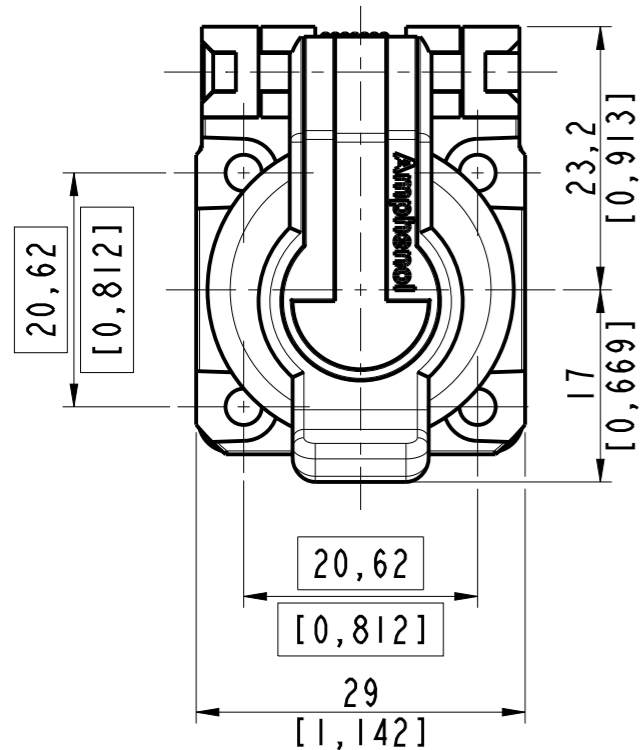

Vue / View A

Tableau / Table F

Référence Part number	L +50mm 0
USBAPSCC2202A	0,2M
USBAPSCC2203A	0,3M
USBAPSCC2205A	0,5M
USBAPSCC2210A	1M
USBAPSCC2215A	1,5 M
USBAPSCC2220A	2 M
USBAPSCC2225A	2,5 M
USBAPSCC2230A	3 M

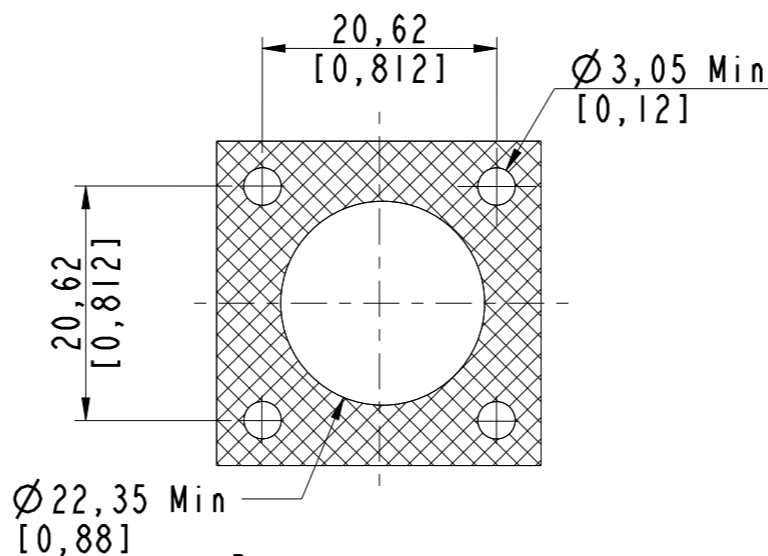
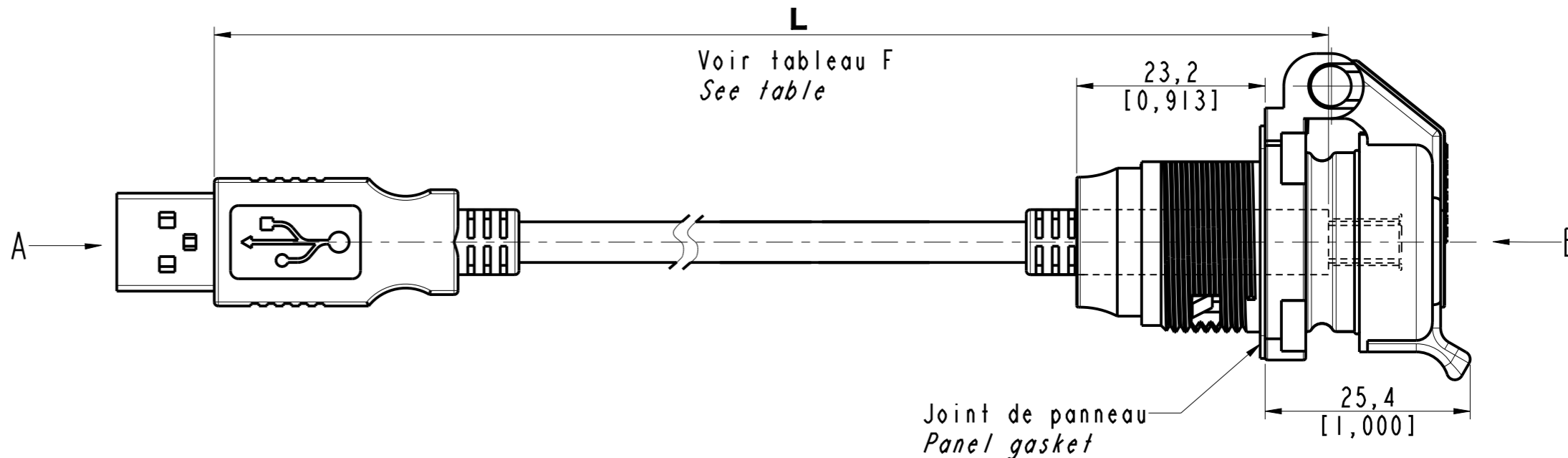

Perçage panneau
Panel drilling

Voir le tableau F pour la longueur
See table F for length

USBAPSCC22XXA
 Cordon assemblage
 Cable assembly

Notas / Notes:

Dimensions en / in mm
Dimensions [] en / in inches

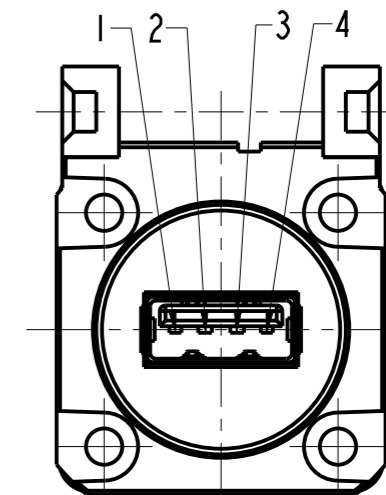

USB-A
Vue B avant sans bouchon
Front view B without cap

Affectation des broches / Pin assignments

USB-A Câblage / Cabling		
Numero du contact Number of contact	Nom du signal Name of signal	Couleur ou nature du conducteur Color or nature of the wire
1	VBUS	Rouge / Red
2	D-	Blanc / White
3	D+	Vert / Green
4	GND	Noir / Black
Corps / Body	Blindage Shielding	Tresse / Braid

MODIFICATIONS	A	Original drawing	ECHELLE
			1,5

Amphenol Socapex
BP 29 - 74311 THYEZ CEDEX

DESSIN: P. Fartade	LE:06/02/18
TECHNIQUE: M. Peters	LE:06/02/18
A	
191-PLC-817-00 1/1	