

THREADED BODY

Zinc-plated steel.

PLUNGER

Nickel-plated AISI 303 stainless steel.

CENTRE BUSH

Zinc-plated steel.

KNOB

High-resilience polyamide based (PA) technopolymer, black colour, matte finish.

FEATURES AND APPLICATIONS

GN 607.3 indexing plungers with rest position can be assembled on thin section sheets or profiles (from 1 to 5 mm). The plunger may not retract completely on its starting position according to the thickness of the sheet "s".



Application example

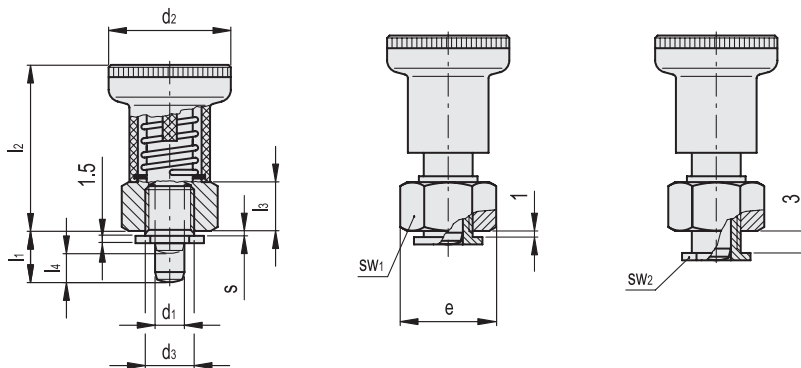
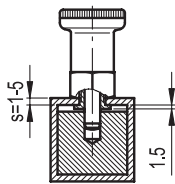

- 1
- 2
- 3
- 4
- 5
- 6
- 7
- 8
- 9
- 10
- 11
- 12
- 13
- 14
- 15
- 16
- 17
- 18

Code	Description	d1 Plunger -0.02 -0.05 Hole H7	d2	d3	e	l1	l2	l3	l4	s	sw1	sw2	Spring preload [N]	Spring max load [N]	Axial holding force [N]	
GN.35078	GN 607.3-6-8.5-ST	6	25	M10	19.5	8.5	34	10	6	1+5	17	14	8.5	22	400	40
GN.35077	GN 607.3-6-10.5-ST	6	25	M10	19.5	10.5	34	10	6	1+5	17	14	8.5	22	400	40
GN.35079	GN 607.3-8-10-ST	8	31	M12	22	10	40	12	7.5	1+5	19	16	15.5	28	500	62
GN.35080	GN 607.3-8-12-ST	8	31	M12	22	12	40	12	7.5	1+5	19	16	15.5	28	500	65

Indexing and positioning elements