

# LM2744 Low Voltage N-Channel MOSFET Synchronous Buck Regulator Controller with External Reference

## General Description

The LM2744 is a high-speed synchronous buck regulator controller with an externally adjustable reference voltage (between 0.5V to 1.5V). It can provide simple down conversion to output voltages as low as 0.5V. Though the control sections of the IC are rated for 3 to 6V, the driver sections are designed to accept input supply rails as high as 16V. The use of adaptive non-overlapping MOSFET gate drivers helps avoid potential shoot-through problems while maintaining high efficiency. The IC is designed for the more cost-effective option of driving only N-channel MOSFETs in both the high-side and low-side positions. It senses the low-side switch voltage drop for providing a simple, adjustable current limit.

The fixed-frequency voltage-mode PWM control architecture is adjustable from 50 kHz to 1 MHz with one external resistor. This wide range of switching frequency gives the power supply designer the flexibility to make better tradeoffs between component size, cost and efficiency.

Features include soft-start, input undervoltage lockout (UV-LO) and Power Good (based on both undervoltage and overvoltage detection). In addition, the shutdown pin of the IC can be used for providing startup delay, and the soft-start pin can be used for implementing precise tracking, for the purpose of sequencing with respect to an external rail.

## Features

- Power stage input voltage from 1V to 16V
- Control stage input voltage from 3V to 6V
- Output voltage adjustable down to 0.5V
- Power good flag and shutdown
- Output overvoltage and undervoltage detection
- External reference voltage 0.5V to 1.5V
- Low-side adjustable current sensing
- Adjustable soft-start
- Tracking and sequencing with shutdown and soft start pins
- Switching frequency from 50 kHz to 1 MHz
- TSSOP-14 package

## Applications

- 3.3V Buck Regulation
- Cable Modem, DSL and ADSL
- Laser Jet and Ink Jet Printers
- Low Voltage Power Modules
- DSP, ASIC, Core and I/O
- DDR Memory Termination Supply

## Typical Application

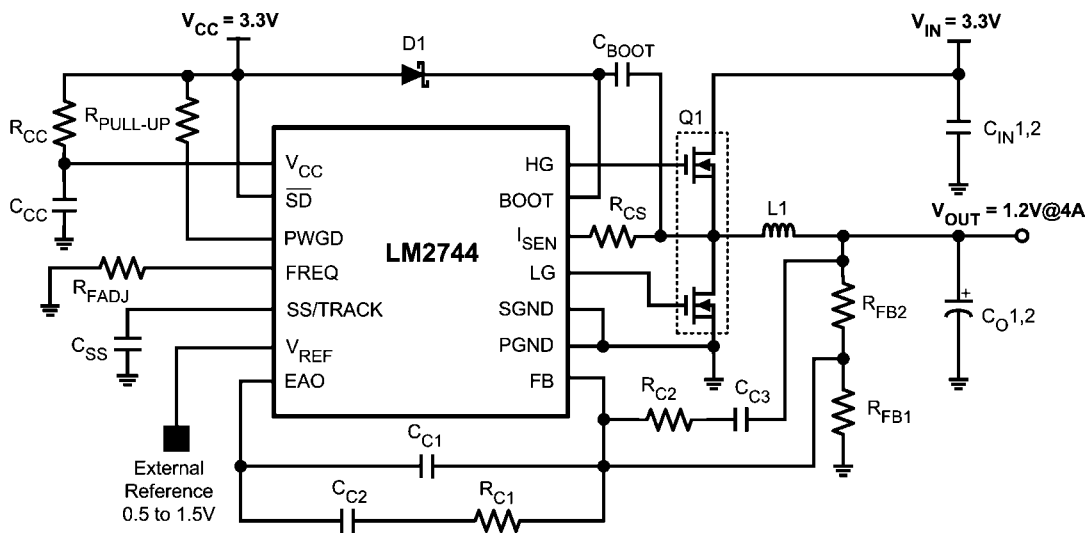

20106001

## Connection Diagram

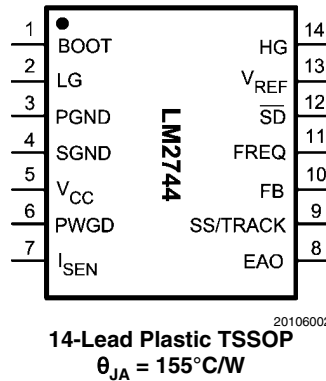

## Ordering Information

Order Number	Package Type	NSC Package Drawing	Supplied As
LM2744MTC	TSSOP-14	MTC14	94 Units, Rail
LM2744MTCX	TSSOP-14	MTC14	2500 Units on Tape and Reel

## Pin Descriptions

**BOOT (Pin 1)** - Bootstrap pin. This is the supply rail for the high-side gate driver. When the high-side MOSFET turns on, the voltage on this pin should be at least one gate threshold above the regulator input voltage  $V_{IN}$  to properly turn on the MOSFET. See MOSFET Gate Drivers in the Application Information section for more details on how to select MOSFETs.

**LG (Pin 2)** - Low-gate drive pin. This is the gate drive for the low-side N-channel MOSFET. This signal is interlocked with the high-side gate drive HG (Pin 14), so as to avoid shoot-through.

**PGND (Pin 3)** - Power ground. This is also the ground for the low-side MOSFET driver. This pin must be connected on the PCB ground plane, which is usually also the system ground.

**SGND (Pin 4)** - Signal ground. It should be connected appropriately to the ground plane with due regard to good layout practices in switching power regulator circuits.

**$V_{CC}$  (Pin 5)** - Supply rail for the control sections of the IC.

**PWGD (Pin 6)** - Power Good pin. This is an open drain output, which is typically meant to be connected to  $V_{CC}$  or any other low voltage source through a pull-up resistor. The voltage on this pin is thus pulled low under output fault conditions (undervoltage or overvoltage) and also under UVLO.

**$I_{SEN}$  (Pin 7)** - Current limit threshold setting pin. This sources a fixed 40  $\mu\text{A}$  current. A resistor of appropriate value should be connected between this pin and the drain of the low-side MOSFET (switch node).

**EAO (Pin 8)** - Output of the error amplifier. The voltage level on this pin is compared with an internally generated ramp signal to determine the duty cycle. This pin is necessary for compensating the control loop.

**SS/TRACK (Pin 9)** - Soft-start and tracking pin. This pin is internally connected to the non-inverting input of the error amplifier during soft-start, and in fact any time the SS/TRACK pin voltage happens to be below the internal reference voltage. For the basic soft-start function, a capacitor of minimum value 1nF is connected from this pin to ground. To track the rising ramp of another power supply's output, connect a resistor divider from the output of that supply to this pin as described in Application Information.

**FB (Pin 10)** - Feedback pin. This is the inverting input of the error amplifier, which is used for sensing the output voltage and compensating the control loop.

**FREQ (Pin 11)** - Frequency adjust pin. The switching frequency is set by connecting a resistor of suitable value between this pin and ground. The equation for calculating the exact value is provided in Application Information, but some typical values (rounded up to the nearest standard values) are 324 k $\Omega$  for 100 kHz, 97.6 k $\Omega$  for 300 kHz, 56.2 k $\Omega$  for 500 kHz, 24.9 k $\Omega$  for 1 MHz.

**$\overline{\text{SD}}$  (Pin 12)** - IC shutdown pin. Pull this pin to  $V_{CC}$  to ensure the IC is enabled. Connect to ground to disable the IC. Under shutdown, both high-side and low-side drives are off. This pin also features a precision threshold for power supply sequencing purposes, as well as a low threshold to ensure minimal quiescent current.

**$V_{REF}$  (Pin 13)** - External reference. This goes to the non-inverting input of the error amplifier. Any desired reference voltage between 0.5V to 1.5V can be connected to this pin (with appropriate filtering if necessary).

**HG (Pin 14)** - High-gate drive pin. This is the gate drive for the high-side N-channel MOSFET. This signal is interlocked with LG (Pin 2) to avoid shoot-through.

**Absolute Maximum Ratings** (Note 1)

If Military/Aerospace specified devices are required, please contact the National Semiconductor Sales Office/Distributors for availability and specifications.

$V_{CC}$	-0.3 to 7V
BOOT Voltage	-0.3 to 21V
All other pins	-0.3 to $V_{CC} + 0.3V$
Junction Temperature	150°C
Storage Temperature	-65°C to 150°C
Soldering Information	
Lead Temperature (soldering, 10sec)	260°C

Infrared or Convection (20sec)

235°C

ESD Rating (Note 3)

2 kV

**Operating Ratings**

Supply Voltage Range ( $V_{CC}$ )	3V to 6V
Junction Temperature Range ( $T_J$ )	-40°C to +125°C
Thermal Resistance ( $\theta_{JA}$ )	155°C/W
Voltage on FB and $V_{REF}$	0.5V to 1.5V

**Electrical Characteristics**

$V_{CC} = 3.3V$  unless otherwise indicated. Typical and limits appearing in plain type apply for  $T_A = T_J = 25^\circ C$ . Limits appearing in boldface type apply over full Operating Temperature Range. Datasheet min/max specification limits are guaranteed by design, test, or statistical analysis.

Symbol	Parameter	Conditions	Min	Typ	Max	Units
$V_{ON}$	UVLO Thresholds	Rising Falling		2.76 2.42		V
$I_{Q\_VCC}$	Operating $V_{CC}$ Current	$V_{CC} = 3.3V, V_{SD} = 3.3V$ $F_{sw} = 600kHz$	<b>1.0</b>	1.5	<b>2.1</b>	mA
		$V_{CC} = 5V, V_{SD} = 3.3V$ $F_{sw} = 600kHz$	<b>1.0</b>	1.7	<b>2.1</b>	
	Shutdown $V_{CC}$ Current	$V_{CC} = 3.3V, V_{SD} = 0V$		1	<b>25</b>	$\mu A$
$t_{PWGD1}$	PWGD Pin Response Time	$V_{FB}$ Rising		6		$\mu s$
$t_{PWGD2}$	PWGD Pin Response Time	$V_{FB}$ Falling		6		$\mu s$
$I_{SS-ON}$	SS Pin Source Current	$V_{SS} = 0V$	<b>5</b>	10	<b>15</b>	$\mu A$
$I_{SS-OC}$	SS Pin Sink Current During Over Current	$V_{SS} = 2.5V$		90		$\mu A$
$I_{SEN-TH}$	$I_{SEN}$ Pin Source Current Trip Point		<b>20</b>	40	<b>60</b>	$\mu A$

**ERROR AMPLIFIER**

$V_{OS}$	Error Amplifier Input Offset Voltage		<b>-8</b>	1	<b>8</b>	mV
GBW	Error Amplifier Unity Gain Bandwidth			9		MHz
G	Error Amplifier DC Gain			106		dB
SR	Error Amplifier Slew Rate			3.2		V/ $\mu s$
$I_{EAO}$	EAO Pin Current Sourcing and Sinking Capability	$V_{EAO} = 1.5, FB = 0.55V$		2.6		mA
		$V_{EAO} = 1.5, FB = 0.65V$		9.2		
$V_{EA}$	Error Amplifier Output Voltage	Minimum		1		V
		Maximum		2		V
$I_{VREF}$	Current into $V_{REF}$ Pin	$1.5V \geq V_{REF} \geq 0.5V$		50		nA

Symbol	Parameter	Conditions	Min	Typ	Max	Units
<b>GATE DRIVE</b>						
$I_{Q-BOOT}$	BOOT Pin Quiescent Current	$V_{BOOT} = 12V, V_{SD} = 0$		18	90	$\mu A$
$R_{HG\_UP}$	High-Side MOSFET Driver Pull-Up ON resistance	$V_{BOOT} - V_{SW} = 9.5V @ 350mA$		3		$\Omega$
$R_{HG\_DN}$	High-Side MOSFET Driver Pull-Down ON resistance	$V_{BOOT} - V_{SW} = 4.5V @ 350mA$		2		$\Omega$
$R_{LG\_UP}$	Low-Side MOSFET Driver Pull-Up ON resistance	$V_{BOOT} - V_{SW} = 9.5V @ 350mA$		3		$\Omega$
$R_{LG\_DN}$	Low-Side MOSFET Driver Pull-Down ON resistance	$V_{BOOT} - V_{SW} = 4.5V @ 350mA$		2		$\Omega$
<b>OSCILLATOR</b>						
$F_{SW}$	PWM Frequency	$R_{FADJ} = 702.1 k\Omega$		50		kHz
		$R_{FADJ} = 98.74 k\Omega$		300		
		$R_{FADJ} = 45.74 k\Omega$	475	600	725	
		$R_{FADJ} = 24.91 k\Omega$		1000		
D	Max High-Side Duty Cycle	$F_{SW} = 300kHz$ $F_{SW} = 600kHz$ $F_{SW} = 1MHz$		80 76 73		%
<b>LOGIC INPUTS AND OUTPUTS</b>						
$V_{STBY-IH}$	Standby High Trip Point	$V_{FB} = 0.575V, V_{BOOT} = 3.3V, V_{SD}$ Rising			1.1	V
$V_{STBY-IL}$	Standby Low Trip Point	$V_{FB} = 0.575V, V_{BOOT} = 3.3V, V_{SD}$ Falling	0.232			V
$V_{SD-IH}$	$\overline{SD}$ Pin Logic High Trip Point	$V_{SD}$ Rising			1.3	V
$V_{SD-IL}$	$\overline{SD}$ Pin Logic Low Trip Point	$V_{SD}$ Falling	0.8			V
$V_{PWGD-TH-LO}$	PWGD Pin Trip Points	FB Falling, $V_{REF} = 0.5V$	0.3262	0.347	0.3678	V
		FB Falling, $V_{REF} = 1.5V$	0.993	1.045	1.097	V
$V_{PWGD-TH-HI}$	PWGD Pin Trip Points	FB Rising, $V_{REF} = 0.5V$	0.551	0.586	0.621	V
		FB Rising, $V_{REF} = 1.5V$	1.6692	1.757	1.8448	V
$V_{PWGD-HYS}$	PWGD Hysteresis	FB Falling		60		mV
		FB Rising		90		

**Note 1:** Absolute maximum ratings indicate limits beyond which damage to the device may occur. **Operating ratings** indicate conditions for which the device operates correctly. **Operating Ratings** do not imply guaranteed performance limits.

**Note 2:** The power MOSFETs can run on a separate 1V to 16V rail (Input voltage,  $V_{IN}$ ). Practical lower limit of  $V_{IN}$  depends on selection of the external MOSFET.

**Note 3:** The human body model is a 100pF capacitor discharged through a 1.5k resistor into each pin.

# Typical Performance Characteristics

**Efficiency ( $V_{OUT} = 1.2V, V_{REF} = 0.6V$ )**  
 $V_{CC} = 3.3V, F_{SW} = 300kHz$

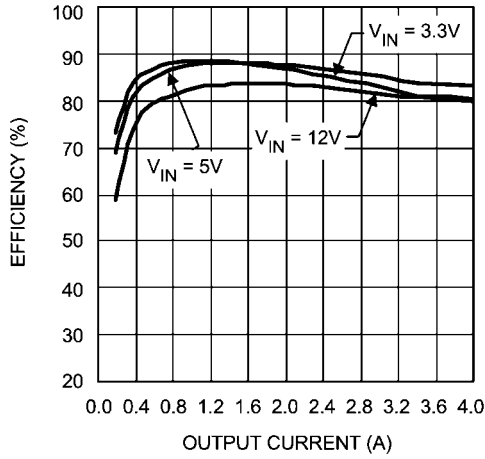

**Efficiency ( $V_{OUT} = 2.5V, V_{REF} = 0.8V$ )**  
 $V_{CC} = 3.3V, F_{SW} = 300kHz$

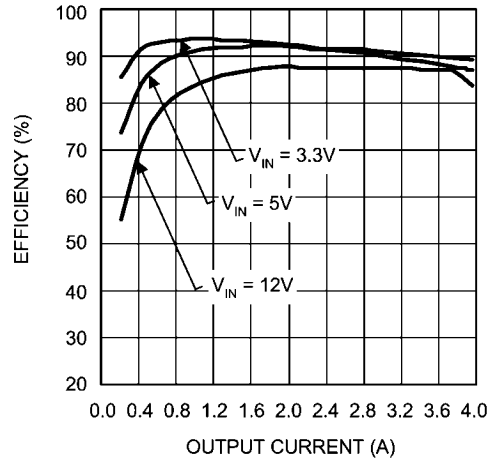

**Efficiency ( $V_{OUT} = 3.3V, V_{REF} = 1.2V$ )**  
 $V_{CC} = 5V, F_{SW} = 300kHz$

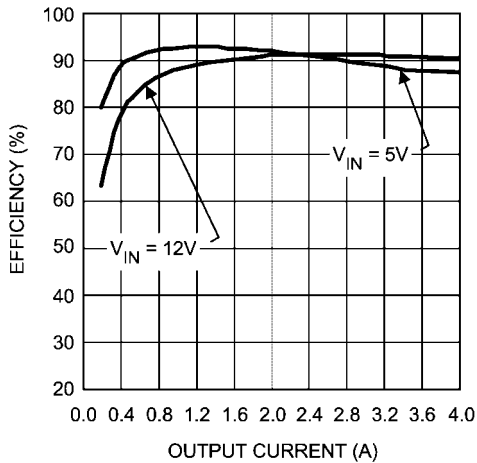

**Output Voltage vs Temperature**

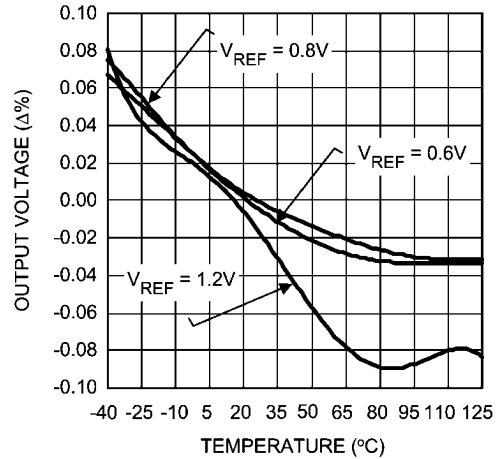

**$V_{CC}$  Operating Current plus BOOT Current vs Frequency**  
**FDS6898A FET ( $T_A = 25^\circ C$ )**

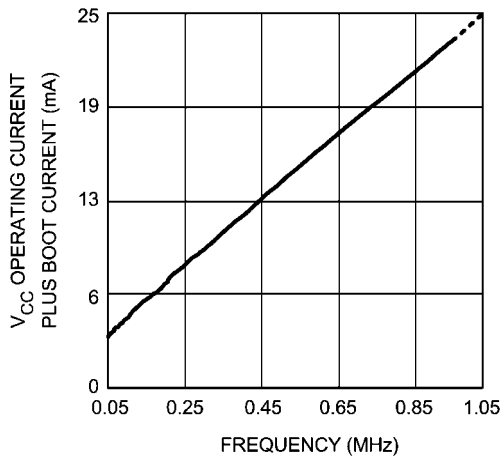

**BOOT Pin Current vs Temperature for**  
**BOOT Voltage = 3.3V**  
 $F_{SW} = 300kHz, FDS6898A FET, No-Load$

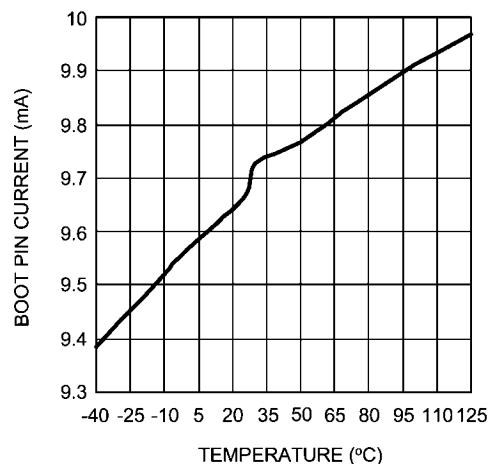

**BOOT Pin Current vs Temperature for  
BOOT Voltage = 5V**  
F<sub>SW</sub> = 300kHz, FDS6898A FET, No-Load

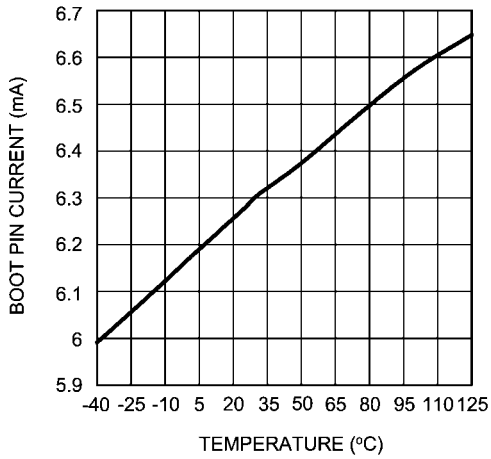

20106042

**BOOT Pin Current vs Temperature for  
BOOT Voltage = 12V**  
F<sub>SW</sub> = 300kHz, FDS6898A FET, No-Load

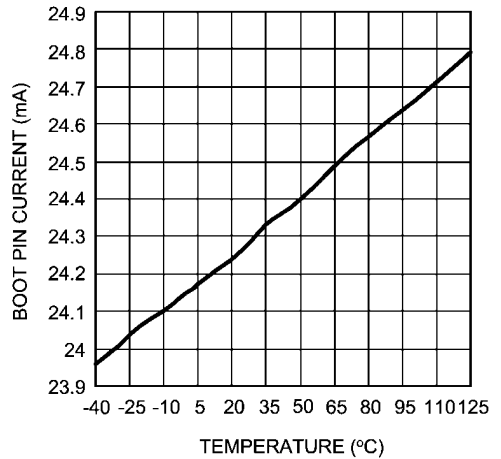

20106044

**Frequency vs Temperature  
(F<sub>SW</sub> set to 600kHz nominal)**

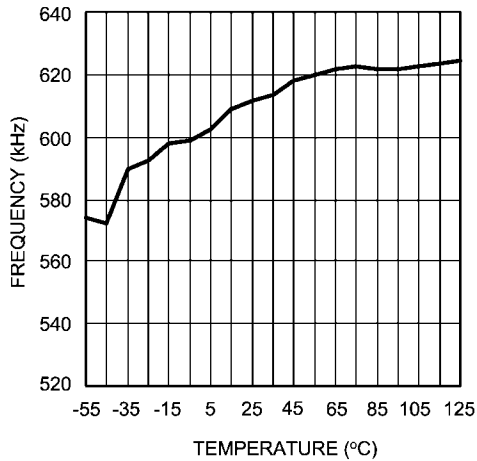

20106060

**Output Voltage vs Output Current  
(V<sub>OUT</sub> set to 1.2V nominal)**

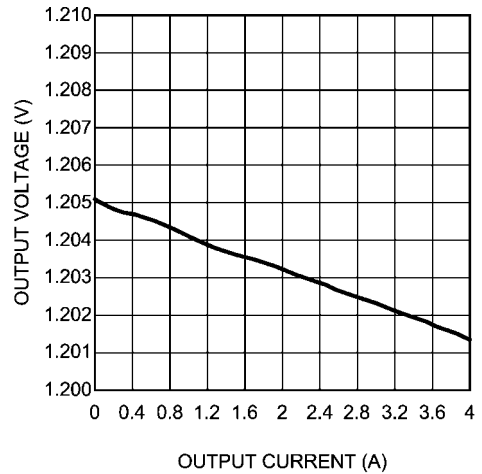

20106056

**Switch Waveforms (HG Rising)**  
V<sub>CC</sub> = 3.3V, V<sub>IN</sub> = 5V, V<sub>REF</sub> = 0.6V, V<sub>OUT</sub> = 1.2V  
I<sub>OUT</sub> = 4A, C<sub>SS</sub> = 12nF, F<sub>SW</sub> = 300kHz

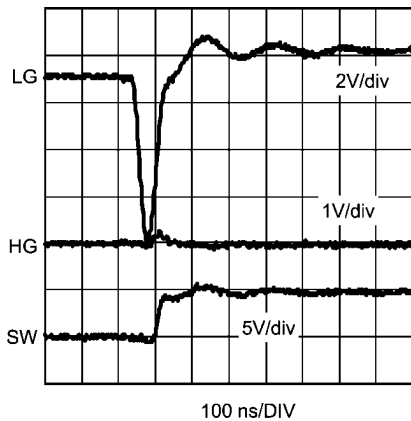

20106046

**Switch Waveforms (HG Falling)**  
V<sub>CC</sub> = 3.3V, V<sub>IN</sub> = 5V, V<sub>REF</sub> = 0.6V, V<sub>OUT</sub> = 1.2V  
I<sub>OUT</sub> = 4A, C<sub>SS</sub> = 12nF, F<sub>SW</sub> = 300kHz

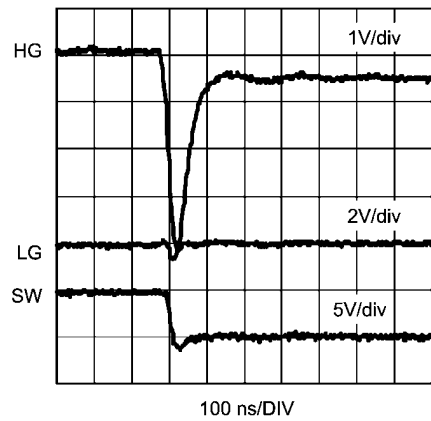

20106047

**Start-Up (No-Load)**  
 $V_{CC} = 3.3V, V_{IN} = 5V, V_{REF} = 0.6V, V_{OUT} = 1.2V$   
 $C_{SS} = 12nF, F_{SW} = 300kHz$

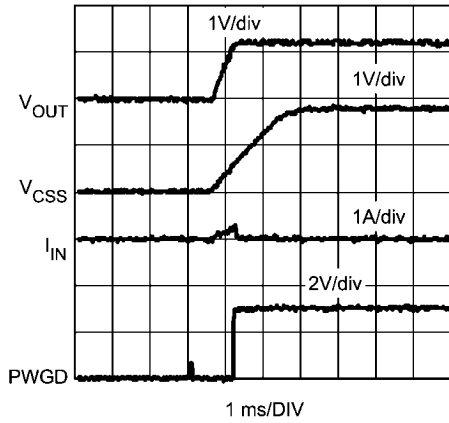

20106048

**Start-Up (Full-Load)**  
 $V_{CC} = 3.3V, V_{IN} = 5V, V_{REF} = 0.6V, V_{OUT} = 1.2V$   
 $I_{OUT} = 4A, C_{SS} = 12nF, F_{SW} = 300kHz$

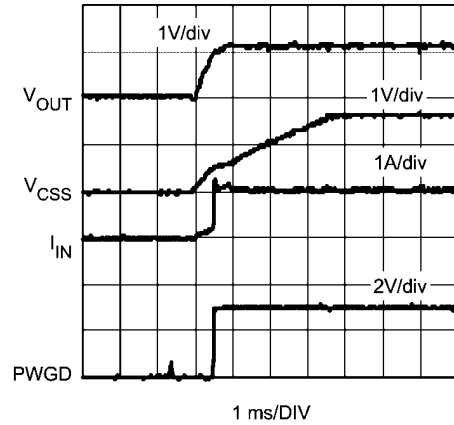

20106049

**Shutdown (Full-Load)**  
 $V_{CC} = 3.3V, V_{IN} = 5V, V_{REF} = 0.6V, V_{OUT} = 1.2V$   
 $I_{OUT} = 4A, C_{SS} = 12nF, F_{SW} = 300kHz$

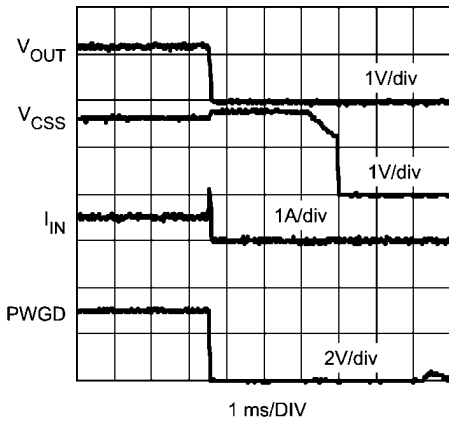

20106050

**Load Transient Response ( $I_{OUT} = 0A$  to  $4A$ )**  
 $V_{CC} = 3.3V, V_{IN} = 5V, V_{REF} = 0.6V, V_{OUT} = 1.2V$   
 $C_{SS} = 12nF, F_{SW} = 300kHz$

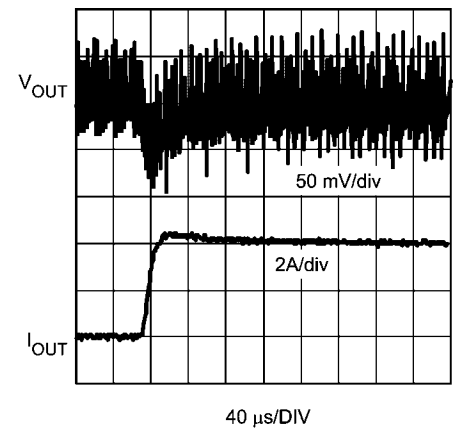

20106051

**Load Transient Response ( $I_{OUT} = 4A$  to  $0A$ )**  
 $V_{CC} = 3.3V, V_{IN} = 5V, V_{REF} = 0.6V, V_{OUT} = 1.2V$   
 $C_{SS} = 12nF, F_{SW} = 300kHz$

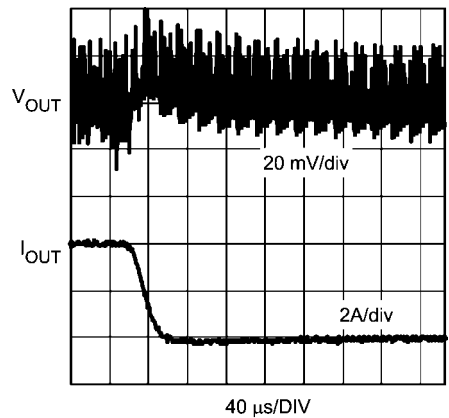

20106052

**Load Transient Response**  
 $V_{CC} = 3.3V, V_{IN} = 5V, V_{REF} = 0.6V, V_{OUT} = 1.2V$   
 $C_{SS} = 12nF, F_{SW} = 300kHz$

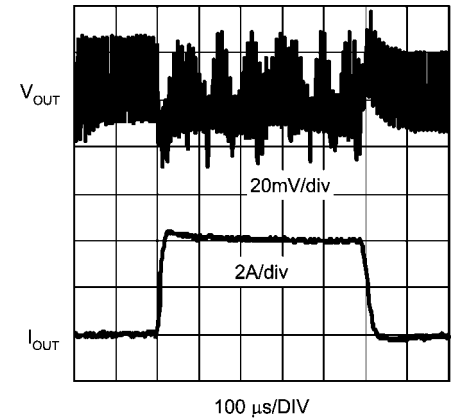

20106053

**Line Transient Response ( $V_{IN} = 3V$  to  $7V$ )**  
 $V_{CC} = 3.3V$ ,  $V_{REF} = 0.6V$ ,  $V_{OUT} = 1.2V$   
 $I_{OUT} = 2A$ ,  $F_{SW} = 300kHz$

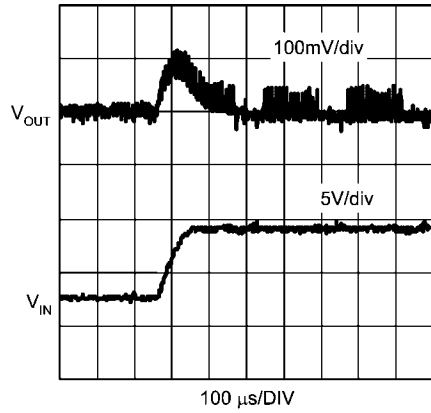

20106054

**Line Transient Response ( $V_{IN} = 7V$  to  $3V$ )**  
 $V_{CC} = 3.3V$ ,  $V_{REF} = 0.6V$ ,  $V_{OUT} = 1.2V$   
 $I_{OUT} = 2A$ ,  $F_{SW} = 300kHz$

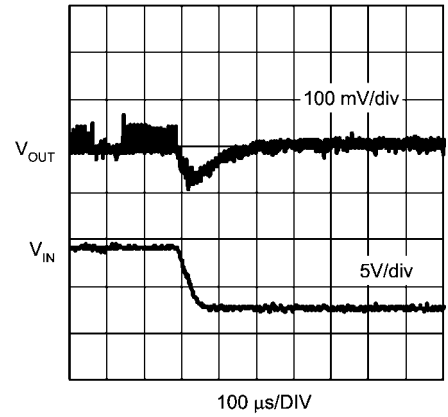

20106055



## Block Diagram

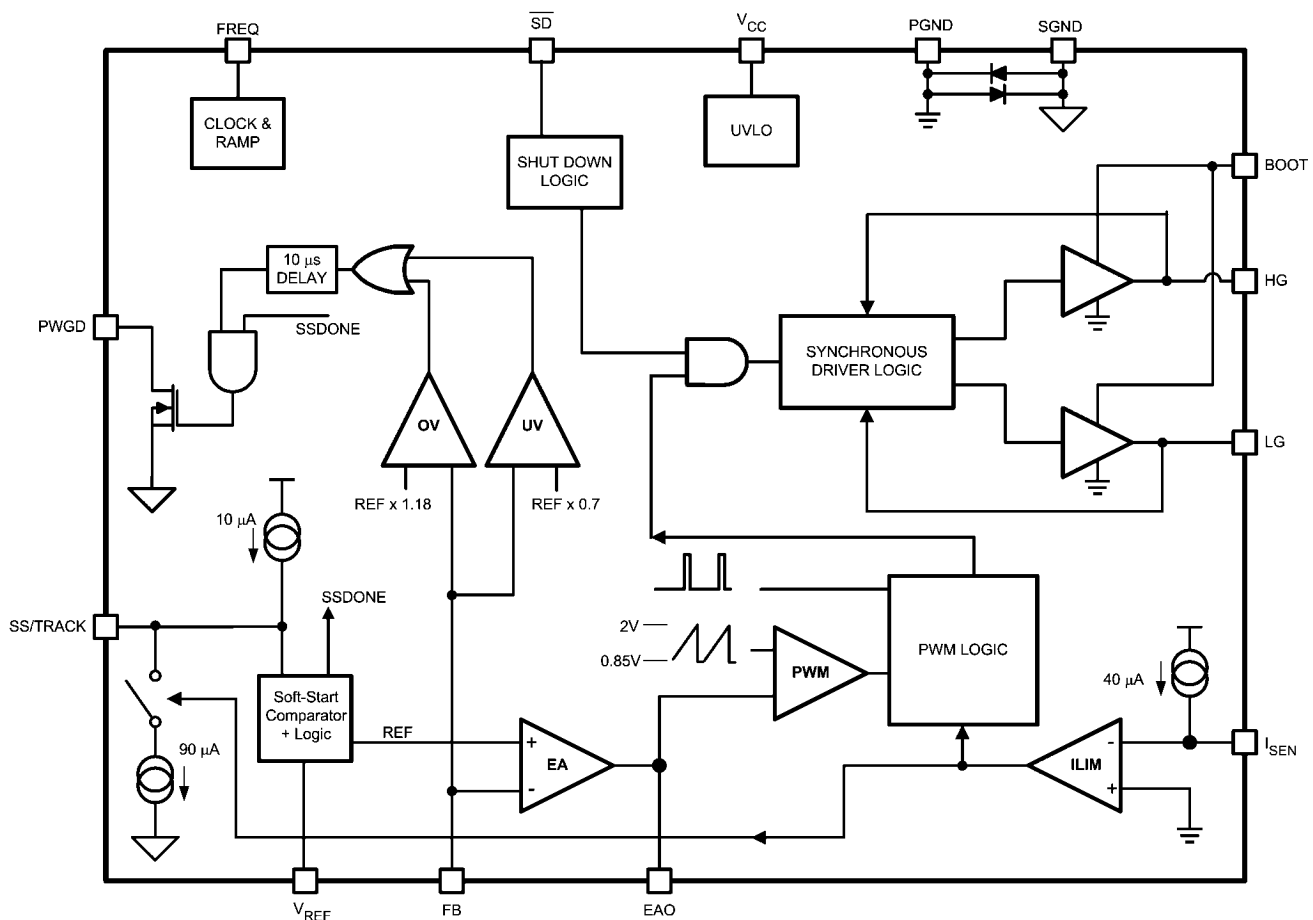

20106003

## Application Information

### THEORY OF OPERATION

The LM2744 is a voltage-mode, high-speed synchronous buck regulator with a PWM control scheme. It is designed for use in set-top boxes, thin clients, DSL/Cable modems, and other applications that require high efficiency buck converters. It has output shutdown ( $\overline{SD}$ ), input undervoltage lock-out (UVLO) mode and power good (PWGD) flag (based on overvoltage and undervoltage detection). The overvoltage and undervoltage signals are OR-gated to drive the power good signal and provide a logic signal to the system if the output voltage goes out of regulation. Current limit is achieved by sensing the voltage  $V_{DS}$  across the low side MOSFET.

### START UP/SOFT-START

When  $V_{CC}$  exceeds 2.76V and the shutdown pin ( $\overline{SD}$ ) sees a logic high, the soft-start period begins. Then an internal, fixed 10  $\mu$ A source begins charging the soft-start capacitor. During soft-start the voltage on the soft-start capacitor  $C_{SS}$  is connected internally to the non-inverting input of the error amplifier. The soft-start period lasts until the voltage on the soft-start capacitor exceeds the LM2744 reference voltage. At this point the reference voltage takes over at the non-inverting error amplifier input. The capacitance of  $C_{SS}$  determines the length of the soft-start period, and can be approximated by:

$$C_{SS} = t_{SS} / (100 \times V_{REF})$$

Where  $C_{SS}$  is in  $\mu$ F and  $t_{SS}$  is in ms.

During soft-start the Power Good flag is forced low and it is released when the FB pin voltage reaches 70% of  $V_{REF}$ . At this point the chip enters normal operation mode, and the output overvoltage and undervoltage monitoring starts.

### NORMAL OPERATION

While in normal operation mode, the LM2744 regulates the output voltage by controlling the duty cycle of the high-side and low-side MOSFETs (see Typical Application Circuit). The equation governing output voltage is:

$$V_{OUT} = \frac{R_{FB1} + R_{FB2}}{R_{FB1}} V_{REF}$$

The PWM frequency is adjustable between 50 kHz and 1 MHz and is set by an external resistor,  $R_{FADJ}$ , between the FREQ pin and ground. The resistance needed for a desired frequency is approximately:

$$R_{FADJ} = -5.93 + 3.06 \frac{10^7}{F_{SW}} + 0.24 \frac{10^{12}}{F_{SW}^2}$$

Where  $F_{SW}$  is in Hz and  $R_{FADJ}$  is in  $k\Omega$ .

### TRACKING A VOLTAGE LEVEL

The LM2744 can track the output of a master power supply during soft-start by connecting a resistor divider to the SS/TRACK pin. In this way, the output voltage slew rate of the LM2744 will be controlled by the master supply for loads that require precise sequencing. Because the output of the master supply is divided down, in order to track properly the output voltage of the LM2744 must be lower than the voltage of the master supply. When the tracking function is used no soft-start capacitor should be connected to the SS/TRACK pin. However in all other cases, a  $C_{SS}$  value of at least 1nF between the soft-start pin and ground should be used.

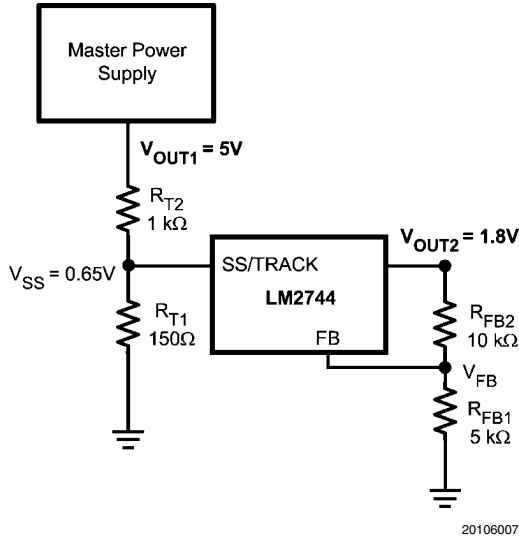

FIGURE 1. Tracking Circuit

One way to use the tracking feature is to design the tracking resistor divider so that the master supply's output voltage ( $V_{OUT1}$ ) and the LM2744's output voltage (represented symbolically in Figure 1 as  $V_{OUT2}$ , i.e. without explicitly showing the power components) both rise together and reach their target values at the same time. For this case, the equation governing the values of the tracking divider resistors  $R_{T1}$  and  $R_{T2}$  is:

$$V_{REF} + 0.05 = \frac{R_{T1}}{R_{T1} + R_{T2}}$$

The current through  $R_{T1}$  should be about 3-4 mA for precise tracking. The final voltage of the SS/TRACK pin should be set slightly higher than the reference voltage (say about 50mV higher as in the above equation). If the master supply voltage was 5V and the LM2744 output voltage was 1.8V, for example, then the value of  $R_{T1}$  needed to give the two supplies identical soft-start times would be 150 $\Omega$  if  $V_{REF}$  was set to 0.6V. A timing diagram for the equal soft-start time case is shown in Figure 2.

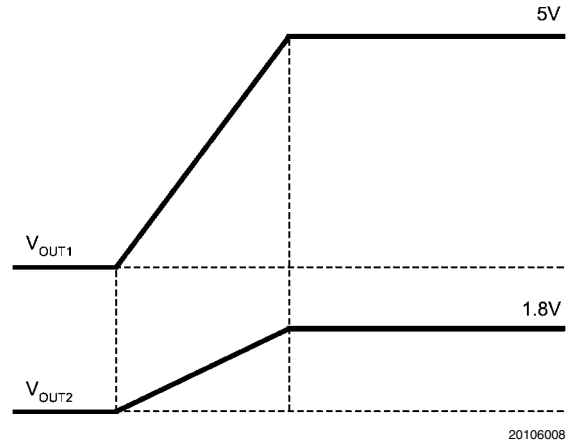

FIGURE 2. Tracking with Equal Soft-Start Time

### TRACKING A VOLTAGE SLEW RATE

The tracking feature can alternatively be used not to make both rails reach regulation at the same time but rather to have similar rise rates (in terms of output  $dV/dt$ ). This method ensures that the output voltage of the LM2744 always reaches regulation before the output voltage of the master supply. In this case, the tracking resistors can be determined based on the following equation:

$$V_{OUT2} = V_{OUT1} \frac{R_{T1}}{R_{T1} + R_{T2}}$$

For the example case of  $V_{OUT1} = 5V$  and  $V_{OUT2} = 1.8V$ , with  $R_{T1}$  set to 150 $\Omega$  as before,  $R_{T2}$  is calculated from the above equation to be 267 $\Omega$ . A timing diagram for the case of equal slew rates is shown in Figure 3.

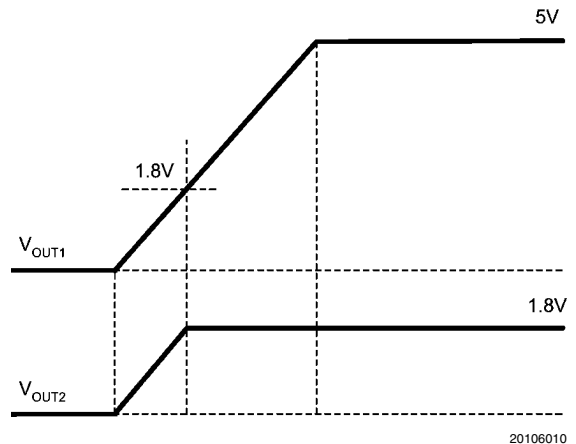

FIGURE 3. Tracking with Equal Slew Rates

### SEQUENCING

The start up/soft-start of the LM2744 can be delayed for the purpose of sequencing by connecting a resistor divider from the output of a master power supply to the  $\overline{SD}$  pin, as shown in Figure 4.

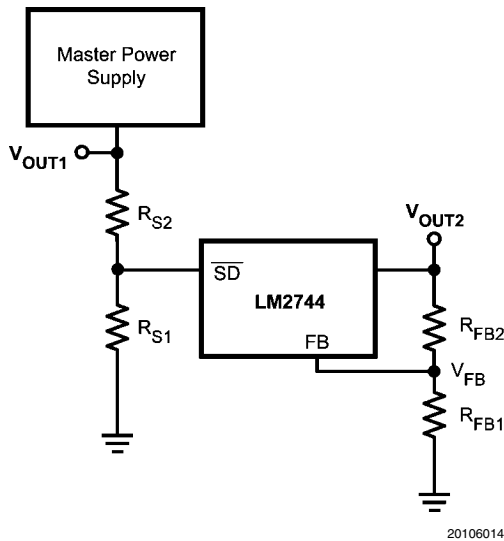

FIGURE 4. Sequencing Circuit

A desired delay time  $t_{\text{DELAY}}$  between the startup of the master supply output voltage and the LM2744 output voltage can be set based on the  $\overline{\text{SD}}$  pin low-to-high threshold  $V_{\text{SD-IH}}$  and the slew rate of the voltage at the  $\overline{\text{SD}}$  pin,  $\text{SR}_{\text{SD}}$ :

$$t_{\text{DELAY}} = V_{\text{SD-IH}} / \text{SR}_{\text{SD}}$$

Note again, that in *Figure 4*, the LM2744's output voltage has been represented symbolically as  $V_{\text{OUT2}}$ , i.e. without explicitly showing the power components.

$V_{\text{SD-IH}}$  is typically 1.08V and  $\text{SR}_{\text{SD}}$  is the slew rate of the  $\overline{\text{SD}}$  pin voltage. The values of the sequencing divider resistors  $R_{\text{S1}}$  and  $R_{\text{S2}}$  set the  $\text{SR}_{\text{SD}}$  based on the master supply output voltage slew rate,  $\text{SR}_{\text{OUT1}}$ , using the following equation:

$$\text{SR}_{\text{SD}} = \text{SR}_{\text{OUT1}} \frac{R_{\text{S1}}}{R_{\text{S1}} + R_{\text{S2}}}$$

For example, if the master supply output voltage slew rate was 1V/ms and the desired delay time between the startup of the master supply and LM2744 output voltage was 5ms, then the desired  $\overline{\text{SD}}$  pin slew rate would be  $(1.08\text{V}/5\text{ms}) = 0.216\text{V/ms}$ . Due to the internal impedance of the  $\overline{\text{SD}}$  pin, the maximum recommended value for  $R_{\text{S2}}$  is 1k $\Omega$ . To achieve the desired slew rate,  $R_{\text{S2}}$  would then be 274 $\Omega$ . A timing diagram for this example is shown in *Figure 5*.

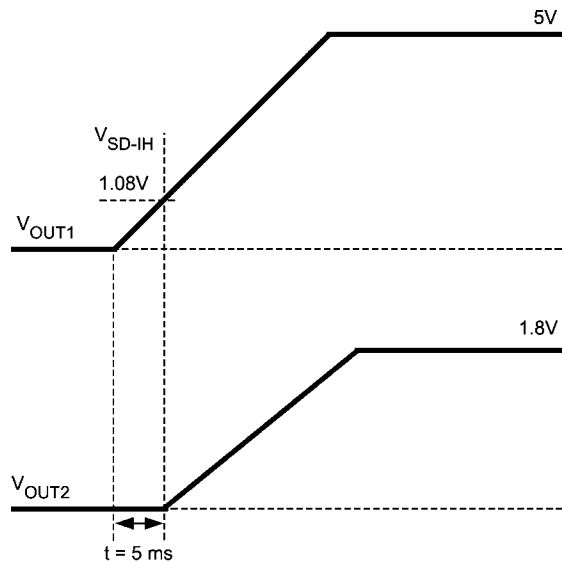
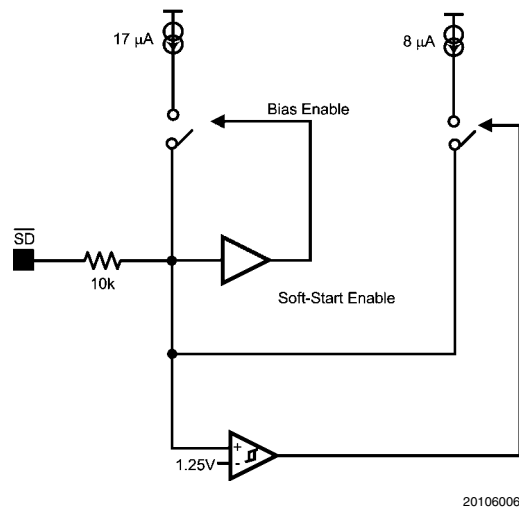

FIGURE 5. Delay for Sequencing

### $\overline{\text{SD}}$ PIN IMPEDANCE

When connecting a resistor divider to the  $\overline{\text{SD}}$  pin of the LM2744 some care has to be taken. Once the  $\overline{\text{SD}}$  voltage goes above  $V_{\text{SD-IH}}$ , a 17  $\mu\text{A}$  pull-up current is activated as shown in *Figure 6*. This current is used to create the internal hysteresis ( $\approx 170\text{mV}$ ); however, high external impedances will affect the  $\overline{\text{SD}}$  pin logic thresholds as well. The external impedance used for the sequencing divider network should preferably be a small fraction of the impedance of the  $\overline{\text{SD}}$  pin for good performance (around 1k $\Omega$ ).

FIGURE 6.  $\overline{\text{SD}}$  Pin Logic

### MOSFET GATE DRIVERS

The LM2744 has two gate drivers designed for driving N-channel MOSFETs in a synchronous mode. Note that unlike most other synchronous controllers, the bootstrap capacitor of the LM2744 provides power not only to the driver of the upper MOSFET, but the lower MOSFET driver too (both drivers are ground referenced, i.e. no floating driver). To fully turn the top MOSFET on, the BOOT voltage must be at least one gate threshold greater than  $V_{\text{IN}}$  when the high-side drive

goes high. This bootstrap voltage is usually supplied from a local charge pump structure. But looking at the Typical Application schematic, this also means that the difference voltage  $V_{CC} - V_{D1}$ , which is the voltage the bootstrap capacitor charges up to, must be always greater than the maximum tolerance limit of the threshold voltage of the upper MOSFET. Here  $V_{D1}$  is the forward voltage drop across the bootstrap diode D1. This therefore may place restrictions on the minimum input voltage and/or type of MOSFET used.

The most basic charge bootstrap pump circuit can be built using one Schottky diode and a small capacitor, as shown in Figure 7. The capacitor  $C_{BOOT}$  serves to maintain enough voltage between the top MOSFET gate and source to control the device even when the top MOSFET is on and its source has risen up to the input voltage level. The charge pump circuitry is fed from  $V_{CC}$ , which can operate over a range from 3.0V to 6.0V. Using this basic method the voltage applied to the gates of both high-side and low-side MOSFETs is  $V_{CC} - V_D$ . This method works well when  $V_{CC}$  is  $5V \pm 10\%$ , because the gate drives will get at least 4.0V of drive voltage during the worst case of  $V_{CC-MIN} = 4.5V$  and  $V_{D-MAX} = 0.5V$ . Logic level MOSFETs generally specify their on-resistance at  $V_{GS} = 4.5V$ . When  $V_{CC} = 3.3V \pm 10\%$ , the gate drive at worst case could go as low as 2.5V. Logic level MOSFETs are not guaranteed to turn on, or may have much higher on-resistance at 2.5V. Sub-logic level MOSFETs, usually specified at  $V_{GS} = 2.5V$ , will work, but are more expensive, and tend to have higher on-resistance. The circuit in Figure 7 works well for input voltages ranging from 1V up to 16V and  $V_{CC} = 5V \pm 10\%$ , because the drive voltage depends only on  $V_{CC}$ .

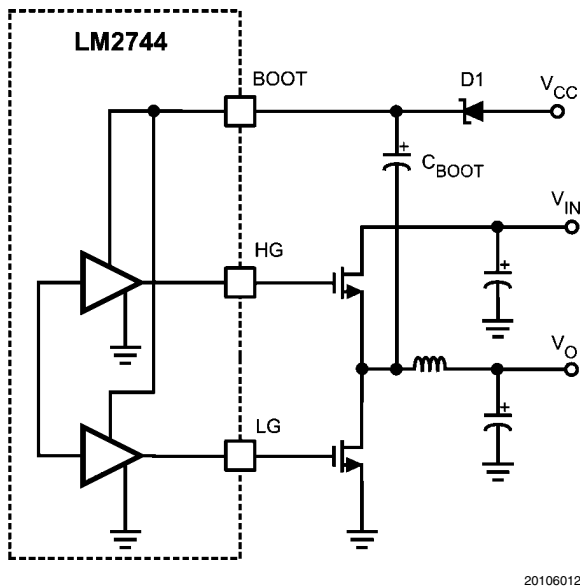

20106012

FIGURE 7. Basic Charge Pump (Bootstrap)

Note that the LM2744 can be paired with a low cost linear regulator like the LP8340 to run from a single input rail between 6.0 and 16V. The 5V output of the linear regulator powers both the  $V_{CC}$  and the bootstrap circuit, providing efficient drive for logic level MOSFETs. An example of this circuit is shown in Figure 8.

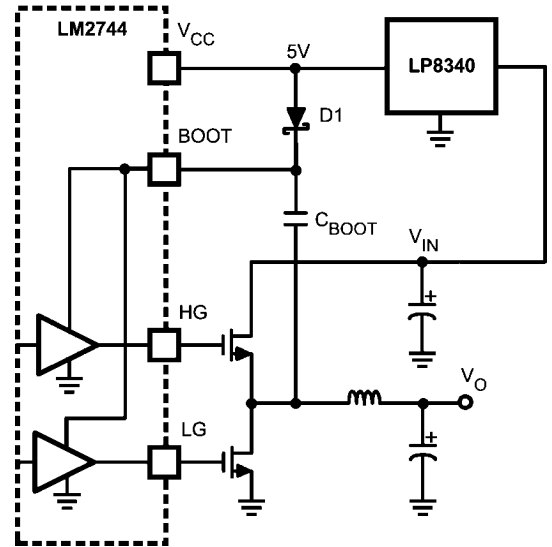

20106013

FIGURE 8. LP8340 Feeding Basic Charge Pump

Figure 9 shows a second possibility for bootstrapping the MOSFET drives using a doubler. This circuit provides an equal voltage drive of  $V_{CC} - 3V_D + V_{IN}$  to both the high-side and low-side MOSFET drives. This method should only be used in circuits that use 3.3V for both  $V_{CC}$  and  $V_{IN}$ . Even with  $V_{IN} = V_{CC} = 3.0V$  (10% lower tolerance on 3.3V) and  $V_D = 0.5V$  both high-side and low-side gates will have at least 4.5V of drive. The power dissipation of the gate drive circuitry is directly proportional to gate drive voltage, hence the thermal limits of the LM2744 IC will quickly be reached if this circuit is used with  $V_{CC}$  or  $V_{IN}$  voltages over 5V.

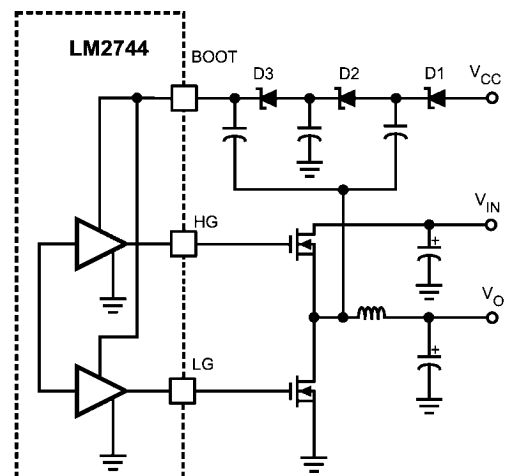

20106019

FIGURE 9. Charge Pump with Added Gate Drive

All the gate drive circuits shown in the above figures typically use 100nF ceramic capacitors in the bootstrap locations.

#### POWER GOOD SIGNAL

The Power Good signal is an OR-gated flag which takes into account both output overvoltage and undervoltage conditions. If the feedback pin (FB) voltage is 18% above its nominal value or falls 28% below that value the Power Good flag goes low. The Power Good flag can be used to signal other

circuits that the output voltage has fallen out of regulation, however the switching of the LM2744 continues regardless of the state of the Power Good signal. The Power Good flag will return to logic high whenever the feedback pin voltage is between 72% and 118% of  $V_{REF}$ .

### UVLO

The 2.76V turn-on threshold on  $V_{CC}$  has a built in hysteresis of about 300mV. If  $V_{CC}$  drops below 2.42V, the chip enters UVLO mode. UVLO consists of turning off the top and bottom MOSFETS and remaining in that condition until  $V_{CC}$  rises above 2.76V. As with shutdown, the soft-start capacitor is discharged through an internal MOSFET, ensuring that the next start-up will be controlled by the soft-start circuitry.

### CURRENT LIMIT

Current limit is realized by sensing the voltage across the low-side MOSFET while it is on. The  $R_{DSON}$  of the MOSFET is a known value; hence the current through the MOSFET can be determined as:

$$V_{DS} = I_{OUT} * R_{DSON}$$

The current through the low-side MOSFET while it is on is also the falling portion of the inductor current. The current limit threshold is determined by an external resistor,  $R_{CS}$ , connected between the switching node and the  $I_{SEN}$  pin. A constant current of 40  $\mu$ A is forced through  $R_{CS}$ , causing a fixed voltage drop. This fixed voltage is compared against  $V_{DS}$  and if the latter is higher, the current limit of the chip has been reached.  $R_{CS}$  can be found by using the following equation:

$$R_{CS} = R_{DSON} * I_{LIM} / 40 \mu A$$

For example, a conservative 15A current limit in a 10A design with a minimum  $R_{DSON}$  of 10m $\Omega$  would require a 3.74k $\Omega$  resistor. Because current sensing is done across the low-side MOSFET, no minimum high-side on-time is necessary. The LM2744 enters current limit mode if the inductor current exceeds the current limit threshold at the point where the high-side MOSFET turns off and the low-side MOSFET turns on. (The point of peak inductor current, see *Figure 10*). Note that in normal operation mode the high-side MOSFET always turns on at the beginning of a clock cycle. In current limit mode, by contrast, the high-side MOSFET on-pulse is skipped. This causes inductor current to fall. Unlike a normal operation switching cycle, however, in a current limit mode switching cycle the high-side MOSFET will turn on as soon as inductor current has fallen to the current limit threshold. The LM2744 will continue to skip high-side MOSFET pulses until the inductor current peak is below the current limit threshold, at which point the system resumes normal operation.

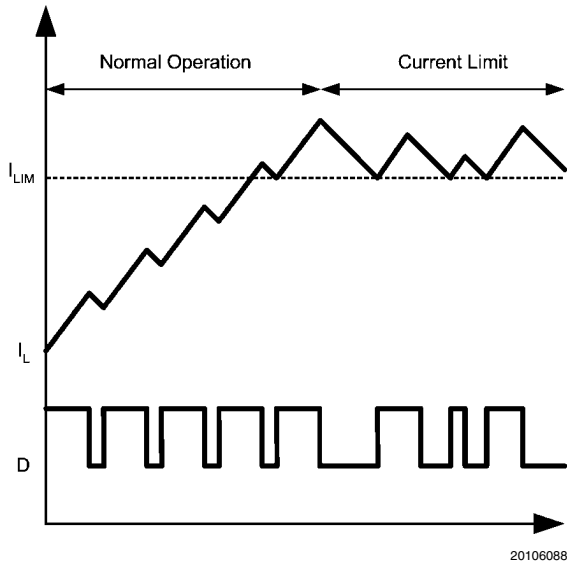

FIGURE 10. Current Limit Threshold

Unlike a high-side MOSFET current sensing scheme, which limits the peaks of inductor current, low-side current sensing is only allowed to limit the current during the converter off-time, when inductor current is falling. Therefore in a typical current limit plot the valleys are normally well defined, but the peaks are variable, according to the duty cycle. The PWM error amplifier and comparator control the off-pulse of the high-side MOSFET, even during current limit mode, meaning that peak inductor current can exceed the current limit threshold. Assuming that the output inductor does not saturate, the maximum peak inductor current during current limit mode can be calculated with the following equation:

$$I_{PK-CL} = I_{LIM} + (T_{OSC} - 200ns) \frac{V_{IN} - V_O}{L}$$

where  $T_{OSC}$  is the inverse of switching frequency  $F_{SW}$ . The 200ns term represents the minimum off-time of the duty cycle, which ensures enough time for correct operation of the current sensing circuitry.

In order to minimize the time period in which peak inductor current exceeds the current limit threshold, the IC also discharges the soft-start capacitor through a fixed 90  $\mu$ A sink. The output of the LM2744 internal error amplifier is limited by the voltage on the soft-start capacitor. Hence, discharging the soft-start capacitor reduces the maximum duty cycle D of the controller. During severe current limit this reduction in duty cycle will reduce the output voltage if the current limit conditions last for an extended time. Output inductor current will be reduced in turn to a flat level equal to the current limit threshold. The third benefit of the soft-start capacitor discharge is a smooth, controlled ramp of output voltage when the current limit condition is cleared.

### SHUTDOWN

If the shutdown pin is pulled low, (below 0.8V) the LM2744 enters shutdown mode, and discharges the soft-start capacitor through a MOSFET switch. The high and low-side MOSFETs are turned off. The LM2744 remains in this state as long as  $V_{SD}$  sees a logic low (see the Electrical Characteristics table). To assure proper IC start-up the shutdown pin should not be left floating. For normal operation this pin should be

connected directly to  $V_{CC}$  or to another voltage between 1.3V to  $V_{CC}$  (see the Electrical Characteristics table).

### DESIGN CONSIDERATIONS

The following is a design procedure for all the components needed to create the Typical Application Circuit shown on the front page. This design converts 3.3V ( $V_{IN}$ ) to 1.2V ( $V_{OUT}$ ) at a maximum load of 4A with an efficiency of 89% and a switching frequency of 300kHz. The same procedures can be followed to create many other designs with varying input voltages, output voltages, and load currents.

#### Input Capacitor

The input capacitors in a Buck converter are subjected to high stress due to the input current trapezoidal waveform. Input capacitors are selected for their ripple current capability and their ability to withstand the heat generated since that ripple current passes through their ESR. Input rms ripple current is approximately:

$$I_{RMS\_RIP} = I_{OUT} \times \sqrt{D(1-D)}$$

where duty cycle  $D = V_{OUT}/V_{IN}$ .

The power dissipated by each input capacitor is:

$$P_{CAP} = \frac{(I_{RMS\_RIP})^2 \times ESR}{n^2}$$

where  $n$  is the number of capacitors, and ESR is the equivalent series resistance of each capacitor. The equation above indicates that power loss in each capacitor decreases rapidly as the number of input capacitors increases. The worst-case ripple for a Buck converter occurs during full load and when the duty cycle ( $D$ ) is 0.5. For this 3.3V to 1.2V design the duty cycle is 0.364. For a 4A maximum load the ripple current is 1.92A.

#### Output Inductor

The output inductor forms the first half of the power stage in a Buck converter. It is responsible for smoothing the square wave created by the switching action and for controlling the output current ripple ( $\Delta I_{OUT}$ ). The inductance is chosen by selecting between tradeoffs in efficiency and response time. The smaller the output inductor, the more quickly the converter can respond to transients in the load current. However, as shown in the efficiency calculations, a smaller inductor requires a higher switching frequency to maintain the same level of output current ripple. An increase in frequency can mean increasing loss in the MOSFETs due to the charging and discharging of the gates. Generally the switching frequency is chosen so that conduction loss outweighs switching loss. The equation for output inductor selection is:

$$L = \frac{V_{IN} - V_{OUT}}{\Delta I_{OUT} \times F_{SW}} \times D$$

$$L = \frac{3.3V - 1.2V}{0.4 \times 4A \times 300 \text{ kHz}} \times \frac{1.2V}{3.3V}$$

$$L = 1.6\mu H$$

Here we have plugged in the values for output current ripple, input voltage, output voltage, switching frequency, and as-

sumed a 40% peak-to-peak output current ripple. This yields an inductance of 1.6  $\mu H$ . The output inductor must be rated to handle the peak current (also equal to the peak switch current), which is  $(I_{OUT} + 0.5 \times \Delta I_{OUT}) = 4.8A$ , for a 4A design. The Coilcraft DO3316P-222P is 2.2  $\mu H$ , is rated to 7.4A peak, and has a direct current resistance (DCR) of 12m $\Omega$ .

After selecting an output inductor, inductor current ripple should be re-calculated with the new inductance value, as this information is needed to select the output capacitor. Re-arranging the equation used to select inductance yields the following:

$$\Delta I_{OUT} = \frac{V_{IN(max)} - V_O}{f_{SW} \times L_{ACTUAL}} \times D$$

$V_{IN(MAX)}$  is assumed to be 10% above the steady state input voltage, or 3.6V. The actual current ripple will then be 1.2A. Peak inductor/switch current will be 4.6A.

#### Output Capacitor

The output capacitor forms the second half of the power stage of a Buck switching converter. It is used to control the output voltage ripple ( $\Delta V_{OUT}$ ) and to supply load current during fast load transients.

In this example the output current is 4A and the expected type of capacitor is an aluminum electrolytic, as with the input capacitors. Other possibilities include ceramic, tantalum, and solid electrolyte capacitors, however the ceramic type often do not have the large capacitance needed to supply current for load transients, and tantalums tend to be more expensive than aluminum electrolytic. Aluminum capacitors tend to have very high capacitance and fairly low ESR, meaning that the ESR zero, which affects system stability, will be much lower than the switching frequency. The large capacitance means that at the switching frequency, the ESR is dominant, hence the type and number of output capacitors is selected on the basis of ESR. One simple formula to find the maximum ESR based on the desired output voltage ripple,  $\Delta V_{OUT}$  and the designed output current ripple,  $\Delta I_{OUT}$ , is:

$$ESR_{MAX} = \frac{\Delta V_{OUT}}{\Delta I_{OUT}}$$

In this example, in order to maintain a 2% peak-to-peak output voltage ripple and a 40% peak-to-peak inductor current ripple, the required maximum ESR is 20m $\Omega$ . The Sanyo 4SP560M electrolytic capacitor will give an equivalent ESR of 14m $\Omega$ . The capacitance of 560  $\mu F$  is enough to supply energy even to meet severe load transient demands.

#### MOSFETs

Selection of the power MOSFETs is governed by a tradeoff between cost, size, and efficiency. One method is to determine the maximum cost that can be endured, and then select the most efficient device that fits that price. Breaking down the losses in the high-side and low-side MOSFETs and then creating spreadsheets is one way to determine relative efficiencies between different MOSFETs. Good correlation between the prediction and the bench result is not guaranteed, however. Single-channel buck regulators that use a controller IC and discrete MOSFETs tend to be most efficient for output currents of 2-10A.

Losses in the high-side MOSFET can be broken down into conduction loss, gate charging loss, and switching loss. Conduction, or  $I^2R$  loss, is approximately:

$$P_C = D (I_O^2 \times R_{DS(ON-HI)} \times 1.3)$$

(High-Side MOSFET)

$$P_C = (1 - D) \times (I_O^2 \times R_{DS(ON-LO)} \times 1.3)$$

(Low-Side MOSFET)

In the above equations the factor 1.3 accounts for the increase in MOSFET  $R_{DS(ON)}$  due to heating. Alternatively, the 1.3 can be ignored and the  $R_{DS(ON)}$  of the MOSFET estimated using the  $R_{DS(ON)}$  Vs. Temperature curves in the MOSFET datasheets.

Gate charging loss results from the current driving the gate capacitance of the power MOSFETs, and is approximated as:

$$P_{GC} = n \times (V_{DD}) \times Q_G \times F_{SW}$$

where 'n' is the number of MOSFETs (if multiple devices have been placed in parallel),  $V_{DD}$  is the driving voltage (see MOSFET Gate Drivers section) and  $Q_{GS}$  is the gate charge of the MOSFET. If different types of MOSFETs are used, the 'n' term can be ignored and their gate charges simply summed to form a cumulative  $Q_G$ . Gate charge loss differs from conduction and switching losses in that the actual dissipation occurs in the LM2744, and not in the MOSFET itself.

Switching loss occurs during the brief transition period as the high-side MOSFET turns on and off, during which both current and voltage are present in the channel of the MOSFET. It can be approximated as:

$$P_{SW} = 0.5 \times V_{IN} \times I_O \times (t_r + t_f) \times F_{SW}$$

where  $t_r$  and  $t_f$  are the rise and fall times of the MOSFET. Switching loss occurs in the high-side MOSFET only.

For this example, the maximum drain-to-source voltage applied to either MOSFET is 3.6V. The maximum drive voltage at the gate of the high-side MOSFET is 3.1V, and the maximum drive voltage for the low-side MOSFET is 3.3V. Due to the low drive voltages in this example, a MOSFET that turns on fully with 3.1V of gate drive is needed. For designs of 5A and under, dual MOSFETs in SO-8 provide a good tradeoff between size, cost, and efficiency.

### Support Components

**$C_{IN2}$**  - A small (0.1 to 1  $\mu$ F) ceramic capacitor should be placed as close as possible to the drain of the high-side MOSFET and source of the low-side MOSFET (dual MOSFETs make this easy). This capacitor should be X5R type dielectric or better.

**$R_{CC}$ ,  $C_{CC}$**  - These are standard filter components designed to ensure smooth DC voltage for the chip supply.  $R_{CC}$  should be 1-10 $\Omega$ .  $C_{CC}$  should be 1  $\mu$ F, X5R type or better.

**$C_{BOOT}$**  - Bootstrap capacitor, typically 100nF.

**$R_{PULL-UP}$**  - This is a standard pull-up resistor for the open-drain power good signal (PWGD). The recommended value is 10 k $\Omega$  connected to  $V_{CC}$ . If this feature is not necessary, the resistor can be omitted.

**$D_1$**  - A small Schottky diode should be used for the bootstrap. It allows for a minimum drop for both high and low-side drivers. The MBR0520 or BAT54 work well in most designs.

**$R_{CS}$**  - Resistor used to set the current limit. Since the design calls for a peak current magnitude ( $I_{OUT} + 0.5 \times \Delta I_{OUT}$ ) of 4.8A, a safe setting would be 6A. (This is below the saturation current of the output inductor, which is 7A.) Following the equation from the Current Limit section, a 1.3k $\Omega$  resistor should be used.

**$R_{FADJ}$**  - This resistor is used to set the switching frequency of the chip. The resistor value is calculated from equation in Normal Operation section. For 300 kHz operation, a 97.6 k $\Omega$  resistor should be used.

**$C_{SS}$**  - The soft-start capacitor depends on the user requirements and is calculated based on the equation given in the section titled *START UP/SOFT-START*. Therefore, for a 7ms delay, a 12nF capacitor is suitable.

### Control Loop Compensation

The LM2744 uses voltage-mode ('VM') PWM control to correct changes in output voltage due to line and load transients. One of the attractive advantages of voltage mode control is its relative immunity to noise and layout. However VM requires careful small signal compensation of the control loop for achieving high bandwidth and good phase margin.

The control loop is comprised of two parts. The first is the power stage, which consists of the duty cycle modulator, output inductor, output capacitor, and load. The second part is the error amplifier, which for the LM2744 is a 9MHz op-amp used in the classic inverting configuration. *Figure 11* shows the regulator and control loop components.

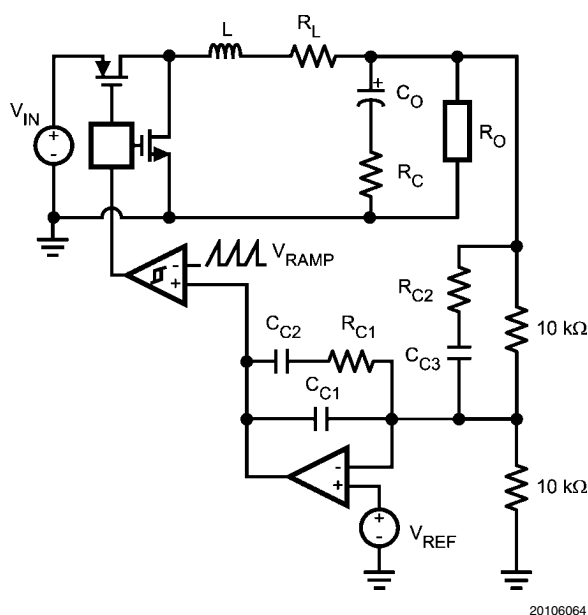

FIGURE 11. Power Stage and Error Amp

One popular method for selecting the compensation components is to create Bode plots of gain and phase for the power stage and error amplifier. Combined, they make the overall bandwidth and phase margin of the regulator easy to see. Software tools such as Excel, MathCAD, and Matlab are useful for showing how changes in compensation or the power stage affect system gain and phase.

The power stage modulator provides a DC gain  $A_{DC}$  that is equal to the input voltage divided by the peak-to-peak value of the PWM ramp. This ramp is 1.0V<sub>P-P</sub> for the LM2744. The inductor and output capacitor create a double pole at frequency  $f_{DP}$ , and the capacitor ESR and capacitance create a single zero at frequency  $f_{ESR}$ . For this example, with  $V_{IN} = 3.3V$ , these quantities are:

$$A_{DC} = \frac{V_{IN}}{V_{RAMP}} = \frac{3.3}{1.0} = 10.4 \text{ dB}$$

$$f_{DP} = \frac{1}{2\pi} \sqrt{\frac{R_O + R_L}{LC_O(R_O + ESR)}} = 4.5 \text{ kHz}$$

$$f_{ESR} = \frac{1}{2\pi C_O ESR} = 20.3 \text{ kHz}$$

In the equation for  $f_{DP}$ , the variable  $R_L$  is the power stage resistance, and represents the inductor DCR plus the on resistance of the high-side MOSFET.  $R_O$  is the output voltage divided by output current. The power stage transfer function  $G_{PS}$  is given by the following equation, and *Figure 12* shows Bode plots of the phase and gain in this example.

$$G_{PS} = \frac{PV_{IN} \times R_O}{V_{RAMP}} \times \frac{sC_O R_C + 1}{a s^2 + b s + c}$$

$$a = LC_O(R_O + R_C)$$

$$b = L + C_O(R_O R_L + R_O R_C + R_C R_L)$$

$$c = R_O + R_L$$

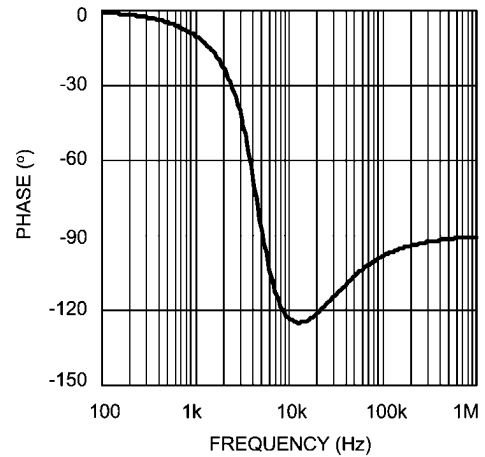
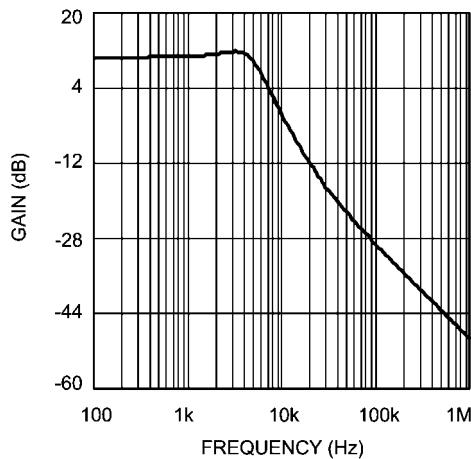

**FIGURE 12. Power Stage Gain and Phase**

The double pole at 4.5kHz causes the phase to drop to approximately  $-130^\circ$  at around 10kHz. The ESR zero, at 20.3kHz, provides a  $+90^\circ$  boost that prevents the phase from dropping to  $-180^\circ$ . If this loop were left uncompensated, the bandwidth would be approximately 10kHz and the phase margin  $53^\circ$ . In theory, the loop would be stable, but would suffer from poor DC regulation (due to the low DC gain) and would be slow to respond to load transients (due to the low bandwidth.) In practice, the loop could easily become unstable due to tolerances in the output inductor, capacitor, or changes in output current, or input voltage. Therefore, the loop is compensated using the error amplifier and a few passive components.

For this example, a Type III, or three-pole-two-zero approach gives optimal bandwidth and phase.

In most voltage mode compensation schemes, including Type III, a single pole is placed at the origin to boost DC gain as high as possible. Two zeroes  $f_{z1}$  and  $f_{z2}$  are placed at the double pole frequency to cancel the double pole phase lag. Then, a pole,  $f_{p1}$  is placed at the frequency of the ESR zero. A final pole  $f_{p2}$  is placed at one-half of the switching frequency. The gain of the error amplifier transfer function is selected to give the best bandwidth possible without violating the Nyquist stability criteria. In practice, a good crossover point is one-fifth of the switching frequency, or 60kHz for this example. The generic equation for the error amplifier transfer function is:

$$G_{EA} = A_{EA} \times \frac{\left(\frac{s}{2\pi f_{z1}} + 1\right)\left(\frac{s}{2\pi f_{z2}} + 1\right)}{s\left(\frac{s}{2\pi f_{p1}} + 1\right)\left(\frac{s}{2\pi f_{p2}} + 1\right)}$$

In this equation the variable  $A_{EA}$  is a ratio of the values of the capacitance and resistance of the compensation components, arranged as shown in *Figure 12*.  $A_{EA}$  is selected to provide the desired bandwidth. A starting value of 80,000 for  $A_{EA}$  should give a conservative bandwidth. Increasing the value will increase the bandwidth, but will also decrease phase margin. Designs with  $45^\circ$ - $60^\circ$  are usually best because they represent a good tradeoff between bandwidth and phase margin. In general, phase margin is lowest and gain highest (worst-case) for maximum input voltage and minimum output



current. One method to select  $A_{EA}$  is to use an iterative process beginning with these worst-case conditions.

1. Increase  $A_{EA}$
2. Check overall bandwidth and phase margin
3. Change  $V_{IN}$  to minimum and recheck overall bandwidth and phase margin
4. Change  $I_O$  to maximum and recheck overall bandwidth and phase margin

The process ends when the both bandwidth and the phase margin are sufficiently high. For this example input voltage can vary from 3.0 to 3.6V and output current can vary from 0 to 4A, and after a few iterations a moderate gain factor of 110,000 is used.

The error amplifier of the LM2744 has a unity-gain bandwidth of 9MHz. In order to model the effect of this limitation, the open-loop gain can be calculated as:

$$OPG = \frac{2\pi \times 9 \text{ MHz}}{s}$$

The new error amplifier transfer function that takes into account unity-gain bandwidth is:

$$H_{EA} = \frac{G_{EA} \times OPG}{1 + G_{EA} + OPG}$$

The gain and phase of the error amplifier are shown in *Figure 13*.

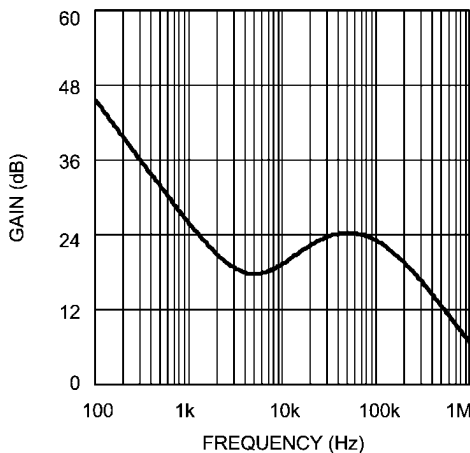

20106074

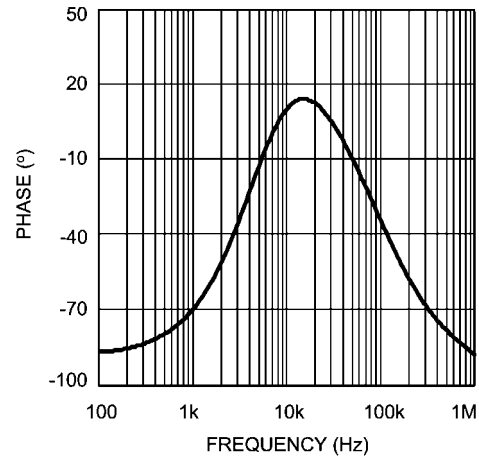

20106075

FIGURE 13. Error Amp Gain and Phase

In VM regulators, the top feedback resistor  $R_{FB2}$  forms a part of the compensation. Setting  $R_{FB2}$  to  $10\text{k}\Omega$ ,  $\pm 1\%$  usually gives values for the other compensation resistors and capacitors that fall within a reasonable range. (Capacitances  $> 1\text{pF}$ , resistances  $< 1\text{M}\Omega$ )  $C_{C1}$ ,  $C_{C2}$ ,  $C_{C3}$ ,  $R_{C1}$ , and  $R_{C2}$  are selected to provide the poles and zeroes at the desired frequencies, using the following equations:

$$C_{C1} = \frac{f_{Z1}}{A_{EA} \times 10,000 \times f_{P2}} = 27 \text{ pF}$$

$$C_{C2} = \frac{1}{A_{EA} \times 10,000} - C_{C1} = 882 \text{ pF}$$

$$C_{C3} = \frac{1}{2\pi \times 10,000} - \left( \frac{1}{f_{Z2}} - \frac{1}{f_{P1}} \right) = 2.73 \text{ nF}$$

$$R_{C1} = \frac{1}{2\pi \times C_{C2} \times f_{Z1}} = 39.8 \text{ k}\Omega$$

$$R_{C2} = \frac{1}{2\pi \times C_{C3} \times f_{P1}} = 2.55 \text{ k}\Omega$$

In practice, a good trade off between phase margin and bandwidth can be obtained by selecting the closest  $\pm 10\%$  capacitor values above what are suggested for  $C_{C1}$  and  $C_{C2}$ , the closest  $\pm 10\%$  capacitor value below the suggestion for  $C_{C3}$ , and the closest  $\pm 1\%$  resistor values below the suggestions for  $R_{C1}$ ,  $R_{C2}$ . Note that if the suggested value for  $R_{C2}$  is less than  $100\Omega$ , it should be replaced by a short circuit. Following this guideline, the compensation components will be:

$$C_{C1} = 27\text{pF} \pm 10\%, C_{C2} = 820\text{pF} \pm 10\%$$

$$C_{C3} = 2.7\text{nF} \pm 10\%, R_{C1} = 39.2\text{k}\Omega \pm 1\%$$

$$R_{C2} = 2.55\text{k}\Omega \pm 1\%$$

The transfer function of the compensation block can be derived by considering the compensation components as impedance blocks  $Z_f$  and  $Z_i$  around an inverting op-amp:

$$G_{EA-ACTUAL} = \frac{Z_F}{Z_I}$$

$$Z_F = \frac{\frac{1}{sC_{C1}} \times \left(10,000 + \frac{1}{sC_{C2}}\right)}{10,000 + \frac{1}{sC_{C1}} + \frac{1}{sC_{C2}}}$$

$$Z_I = \frac{R_{C1} \left( R_{C2} + \frac{1}{sC_{C3}} \right)}{R_{C1} + R_{C2} + \frac{1}{sC_{C3}}}$$

As with the generic equation,  $G_{EA-ACTUAL}$  must be modified to take into account the limited bandwidth of the error amplifier. The result is:

$$H_{EA} = \frac{G_{EA-ACTUAL} \times OPG}{1 + G_{EA-ACTUAL} + OPG}$$

The total control loop transfer function  $H$  is equal to the power stage transfer function multiplied by the error amplifier transfer function.

$$H = G_{PS} \times H_{EA}$$

The bandwidth and phase margin can be read graphically from Bode plots of  $H_{EA}$  are shown in *Figure 14*.

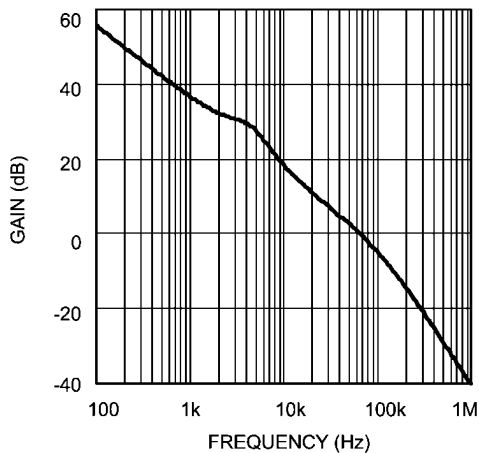

20106085

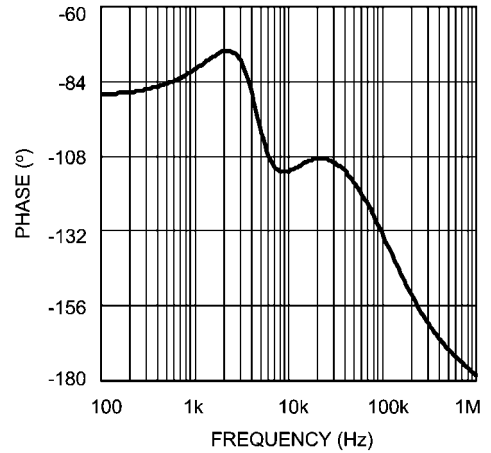

20106086

**FIGURE 14. Overall Loop Gain and Phase**

The bandwidth of this example circuit is 59kHz, with a phase margin of 60°.

### EFFICIENCY CALCULATIONS

The following is a sample calculation.

A reasonable estimation of the efficiency of a switching buck controller can be obtained by adding together the Output Power ( $P_{OUT}$ ) loss and the Total Power ( $P_{TOTAL}$ ) loss:

$$\eta = \frac{P_{OUT}}{P_{OUT} + P_{TOTAL}} \times 100\%$$

The Output Power ( $P_{OUT}$ ) for the Typical Application Circuit design is  $(1.2V \times 4A) = 4.8W$ . The Total Power ( $P_{TOTAL}$ ), with an efficiency calculation to complement the design, is shown below.

The majority of the power losses are due to low and high-side of MOSFET's losses. The losses in any MOSFET are group of switching ( $P_{SW}$ ) and conduction losses ( $P_{CND}$ ).

$$P_{FET} = P_{SW} + P_{CND} = 61.38mW + 270.42mW$$

$$P_{FET} = 331.8mW$$

### FET Switching Loss ( $P_{SW}$ )

$$P_{SW} = P_{SW(ON)} + P_{SW(OFF)}$$

$$P_{SW} = 0.5 \times V_{IN} \times I_{OUT} \times (t_r + t_f) \times F_{OSC}$$

$$P_{SW} = 0.5 \times 3.3V \times 4A \times 300kHz \times 31ns$$

$$P_{SW} = 61.38mW$$

The FDS6898A has a typical turn-on rise time  $t_r$  and turn-off fall time  $t_f$  of 15ns and 16ns, respectively. The switching losses for this type of dual N-Channel MOSFETs are 0.061W.

### FET Conduction Loss ( $P_{CND}$ )

$$P_{CND} = P_{CND1} + P_{CND2}$$

$$P_{CND1} = I_{OUT}^2 \times R_{DS(ON)} \times k \times D$$

$$P_{CND2} = I_{OUT}^2 \times R_{DS(ON)} \times k \times (1-D)$$

$R_{DS(ON)} = 13m\Omega$  and the factor is a constant value ( $k = 1.3$ ) to account for the increasing  $R_{DS(ON)}$  of a FET due to heating.

$$P_{CND1} = (4A)^2 \times 13m\Omega \times 1.3 \times 0.364$$

$$P_{CND2} = (4A)^2 \times 13m\Omega \times 1.3 \times (1 - 0.364)$$

$$P_{CND} = 98.42mW + 172mW = 270.42mW$$

There are few additional losses that are taken into account:

#### IC Operating Loss ( $P_{IC}$ )

$$P_{IC} = I_{Q-VCC} \times V_{CC},$$

where  $I_{Q-VCC}$  is the typical operating  $V_{CC}$  current

$$P_{IC} = 1.5\text{mA} \times 3.3\text{V} = 4.95\text{mW}$$

#### FET Gate Charging Loss ( $P_{GATE}$ )

$$P_{GATE} = n \times V_{CC} \times Q_{GS} \times F_{OSC}$$

$$P_{GATE} = 2 \times 3.3\text{V} \times 3\text{nC} \times 300\text{kHz}$$

$$P_{GATE} = 5.94\text{mW}$$

The value  $n$  is the total number of FETs used and  $Q_{GS}$  is the typical gate-source charge value, which is 3nC. For the FD-S6898A the gate charging loss is 5.94mW.

#### Input Capacitor Loss ( $P_{CAP}$ )

$$P_{CAP} = \frac{(I_{RMS\_RIP})^2 \times ESR}{n^2}$$

where,

$$I_{RMS\_RIP} = I_{OUT} \times \sqrt{D(1-D)}$$

Here  $n$  is the number of paralleled capacitors, ESR is the equivalent series resistance of each, and  $P_{CAP}$  is the dissipa-

tion in each. So for example if we use only one input capacitor of 24 mΩ.

$$P_{CAP} = \frac{(1.924\text{A})^2 \times 24\text{m}\Omega}{1^2}$$

$$P_{CAP} = 88.8\text{mW}$$

#### Output Inductor Loss ( $P_{IND}$ )

$$P_{IND} = I_{OUT}^2 \times DCR$$

where DCR is the DC resistance. Therefore, for example

$$P_{IND} = (4\text{A})^2 \times 11\text{m}\Omega$$

$$P_{IND} = 176\text{mW}$$

#### Total System Efficiency

$$\eta = \frac{P_{OUT}}{P_{OUT} + P_{TOTAL}} \times 100\%$$

$$\eta = \frac{4.8\text{W}}{4.8\text{W} + 0.6\text{W}} = 89\%$$

## Example Circuits

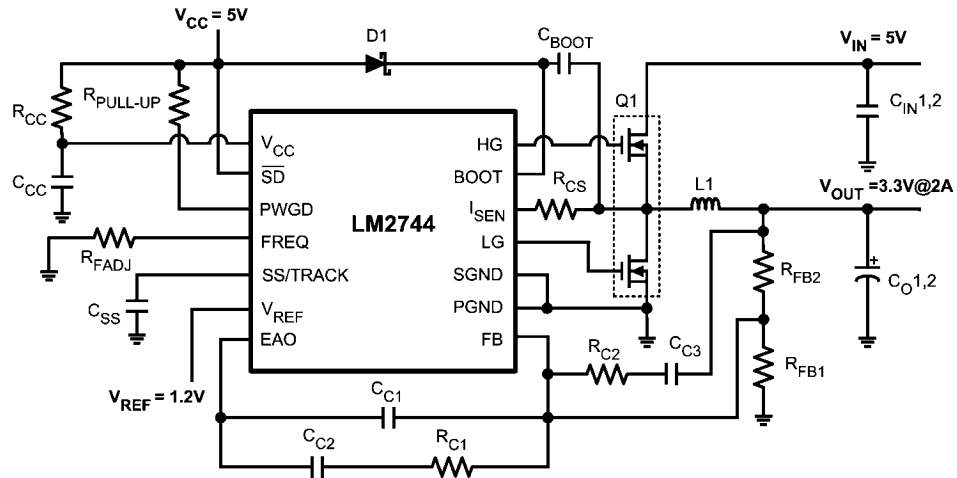

20106032

FIGURE 15. 5V to 3.3V @ 2A,  $V_{REF} = 1.2V$ ,  $F_{SW} = 300kHz$

PART	PART NUMBER	TYPE	PACKAGE	DESCRIPTION	VENDOR
U <sub>1</sub>	LM2744	Synchronous Controller	TSSOP-14		NSC
Q <sub>1</sub>	FDS6898A	Dual N-MOSFET	SO-8	20V, 10mΩ @ 4.5V, 16nC	Fairchild
D <sub>1</sub>	MBR0520LT1	Schottky Diode	SOD-123		
L <sub>1</sub>	DO3316P-472	Inductor	12.95 x 9.4 x 5.21mm	4.7µH, 4.8Arms 18mΩ	Coilcraft
C <sub>IN1</sub>	16SP100M	Aluminum Electrolytic	10mm x 6mm	100µF, 16V, 2.89Arms	Sanyo
C <sub>O1</sub>	6SP220M	Aluminum Electrolytic	10mm x 6mm	220µF, 6.3V 3.1Arms	Sanyo
C <sub>BOOT</sub> , C <sub>IN2</sub> , C <sub>O2</sub>	VJ0805Y104KXXA	Capacitor	0805	0.1µF, 10%	Vishay
C <sub>CC</sub>	VJ0805M104MXQ	Capacitor	0805	1µF, 20%	Vishay
C <sub>C3</sub>	VJ0805Y332KXXA	Capacitor	0805	3300pF, 10%	Vishay
C <sub>SS</sub>	VJ0805A123KXAA	Capacitor	0805	12nF, 10%	Vishay
C <sub>C2</sub>	VJ0805Y122KXXA	Capacitor	0805	1200pF 10%	Vishay
C <sub>C1</sub>	VJ0805A270KXAA	Capacitor	0805	27pF, 10%	Vishay
R <sub>FB2</sub>	CRCW08051002F	Resistor	0805	10.0kΩ 1%	Vishay
R <sub>FB1</sub>	CRCW08055761F	Resistor	0805	5.76kΩ 1%	Vishay
R <sub>FADJ</sub>	CRCW08051103F	Resistor	0805	110kΩ 1%	Vishay
R <sub>C2</sub>	CRCW08052101F	Resistor	0805	2.1kΩ 1%	Vishay
R <sub>CS</sub>	CRCW08057870F	Resistor	0805	787Ω 1%	Vishay
R <sub>CC</sub>	CRCW080510R0F	Resistor	0805	10.0Ω 1%	Vishay
R <sub>C1</sub>	CRCW08053832F	Resistor	0805	38.3kΩ 1%	Vishay
R <sub>PULL-UP</sub>	CRCW08051003J	Resistor	0805	100kΩ 5%	Vishay

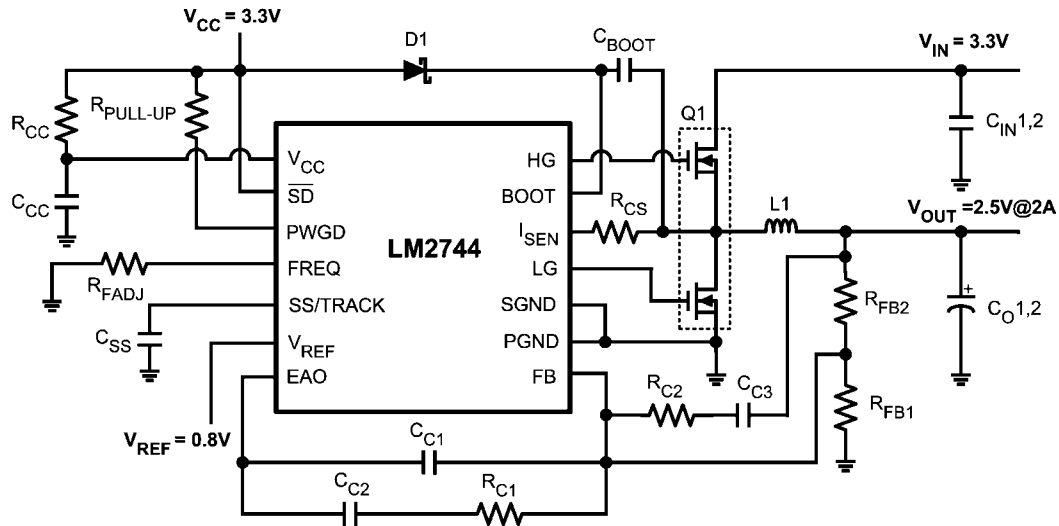

20106034

FIGURE 16. 3.3V to 2.5V @ 2A,  $V_{REF} = 0.8V$ ,  $F_{SW} = 300kHz$

PART	PART NUMBER	TYPE	PACKAGE	DESCRIPTION	VENDOR
U <sub>1</sub>	LM2744	Synchronous Controller	TSSOP-14		NSC
Q <sub>1</sub>	FDS6898A	Dual N-MOSFET	SO-8	20V, 10mΩ @ 4.5V, 16nC	Fairchild
D <sub>1</sub>	MBR0520LTI	Schottky Diode	SOD-123		
L <sub>1</sub>	DO3316P-332	Inductor	12.95 x 9.4 x 5.21mm	3.3μH, 5.4Arms 15mΩ	Coilcraft
C <sub>IN1</sub>	16SP100M	Aluminum Electrolytic	10mm x 6mm	100μF, 16V 2.89Arms	Sanyo
C <sub>O1</sub>	6SP220M	Aluminum Electrolytic	10mm x 6mm	220μF, 6.3V 3.1Arms	Sanyo
C <sub>BOOT</sub> , C <sub>IN2</sub> , C <sub>O2</sub>	VJ0805Y104KXXA	Capacitor	0805	0.1μF, 10%	Vishay
C <sub>CC</sub>	VJ0805M104MXQ	Capacitor	0805	1μF, 20%	Vishay
C <sub>C3</sub>	VJ0805Y222KXXA	Capacitor	0805	2200pF, 10%	Vishay
C <sub>SS</sub>	VJ0805A123KXAA	Capacitor	0805	12nF, 10%	Vishay
C <sub>C2</sub>	VJ0805Y272KXAA	Capacitor	0805	2700pF 10%	Vishay
C <sub>C1</sub>	VJ0805A820KXAA	Capacitor	0805	82pF, 10%	Vishay
R <sub>FB2</sub>	CRCW08051002F	Resistor	0805	10.0kΩ 1%	Vishay
R <sub>FB1</sub>	CRCW08054641F	Resistor	0805	4.64kΩ 1%	Vishay
R <sub>FADJ</sub>	CRCW08051103F	Resistor	0805	110kΩ 1%	Vishay
R <sub>C2</sub>	CRCW08052551F	Resistor	0805	2.55kΩ 1%	Vishay
R <sub>CS</sub>	CRCW08058450F	Resistor	0805	845Ω 1%	Vishay
R <sub>CC</sub>	CRCW080510R0F	Resistor	0805	10.0Ω 1%	Vishay
R <sub>C1</sub>	CRCW08051372F	Resistor	0805	13.7kΩ 1%	Vishay
R <sub>PULL-UP</sub>	CRCW08051003J	Resistor	0805	100kΩ 5%	Vishay

**Physical Dimensions** inches (millimeters) unless otherwise noted

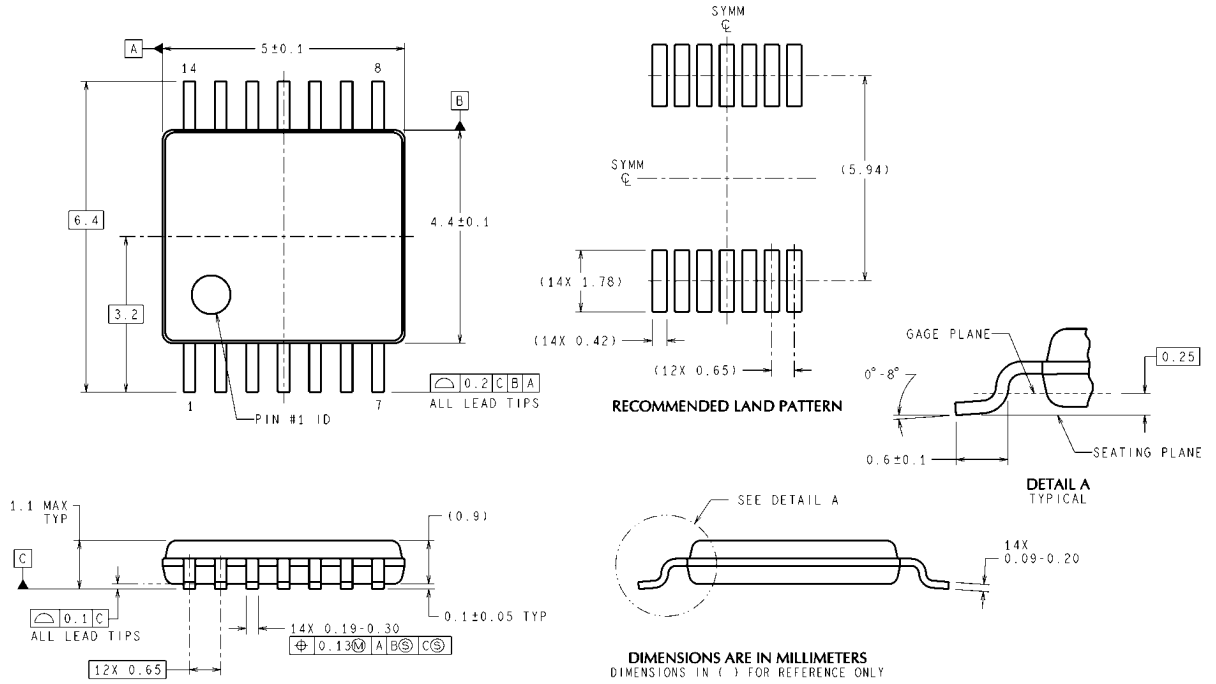

DIMENSIONS ARE IN MILLIMETERS  
DIMENSIONS IN ( ) FOR REFERENCE ONLY

**TSSOP-14 Pin Package**  
**NS Package Number MTC14**

MTC14 (Rev D)

# Notes

LM2744

## Notes

THE CONTENTS OF THIS DOCUMENT ARE PROVIDED IN CONNECTION WITH NATIONAL SEMICONDUCTOR CORPORATION ("NATIONAL") PRODUCTS. NATIONAL MAKES NO REPRESENTATIONS OR WARRANTIES WITH RESPECT TO THE ACCURACY OR COMPLETENESS OF THE CONTENTS OF THIS PUBLICATION AND RESERVES THE RIGHT TO MAKE CHANGES TO SPECIFICATIONS AND PRODUCT DESCRIPTIONS AT ANY TIME WITHOUT NOTICE. NO LICENSE, WHETHER EXPRESS, IMPLIED, ARISING BY ESTOPPEL OR OTHERWISE, TO ANY INTELLECTUAL PROPERTY RIGHTS IS GRANTED BY THIS DOCUMENT.

TESTING AND OTHER QUALITY CONTROLS ARE USED TO THE EXTENT NATIONAL DEEMS NECESSARY TO SUPPORT NATIONAL'S PRODUCT WARRANTY. EXCEPT WHERE MANDATED BY GOVERNMENT REQUIREMENTS, TESTING OF ALL PARAMETERS OF EACH PRODUCT IS NOT NECESSARILY PERFORMED. NATIONAL ASSUMES NO LIABILITY FOR APPLICATIONS ASSISTANCE OR BUYER PRODUCT DESIGN. BUYERS ARE RESPONSIBLE FOR THEIR PRODUCTS AND APPLICATIONS USING NATIONAL COMPONENTS. PRIOR TO USING OR DISTRIBUTING ANY PRODUCTS THAT INCLUDE NATIONAL COMPONENTS, BUYERS SHOULD PROVIDE ADEQUATE DESIGN, TESTING AND OPERATING SAFEGUARDS.

EXCEPT AS PROVIDED IN NATIONAL'S TERMS AND CONDITIONS OF SALE FOR SUCH PRODUCTS, NATIONAL ASSUMES NO LIABILITY WHATSOEVER, AND NATIONAL DISCLAIMS ANY EXPRESS OR IMPLIED WARRANTY RELATING TO THE SALE AND/OR USE OF NATIONAL PRODUCTS INCLUDING LIABILITY OR WARRANTIES RELATING TO FITNESS FOR A PARTICULAR PURPOSE, MERCHANTABILITY, OR INFRINGEMENT OF ANY PATENT, COPYRIGHT OR OTHER INTELLECTUAL PROPERTY RIGHT.

### LIFE SUPPORT POLICY

**NATIONAL'S PRODUCTS ARE NOT AUTHORIZED FOR USE AS CRITICAL COMPONENTS IN LIFE SUPPORT DEVICES OR SYSTEMS WITHOUT THE EXPRESS PRIOR WRITTEN APPROVAL OF THE CHIEF EXECUTIVE OFFICER AND GENERAL COUNSEL OF NATIONAL SEMICONDUCTOR CORPORATION.** As used herein:

Life support devices or systems are devices which (a) are intended for surgical implant into the body, or (b) support or sustain life and whose failure to perform when properly used in accordance with instructions for use provided in the labeling can be reasonably expected to result in a significant injury to the user. A critical component is any component in a life support device or system whose failure to perform can be reasonably expected to cause the failure of the life support device or system or to affect its safety or effectiveness.

National Semiconductor and the National Semiconductor logo are registered trademarks of National Semiconductor Corporation. All other brand or product names may be trademarks or registered trademarks of their respective holders.

Copyright© 2007 National Semiconductor Corporation

For the most current product information visit us at [www.national.com](http://www.national.com)



**National Semiconductor Americas Customer Support Center**  
 Email: [new.feedback@nsc.com](mailto:new.feedback@nsc.com)  
 Tel: 1-800-272-9959

**National Semiconductor Europe Customer Support Center**  
 Fax: +49 (0) 180-530-85-86  
 Email: [europe.support@nsc.com](mailto:europe.support@nsc.com)  
 Deutsch Tel: +49 (0) 69 9508 6208  
 English Tel: +49 (0) 870 24 0 2171  
 Français Tel: +33 (0) 1 41 91 8790

**National Semiconductor Asia Pacific Customer Support Center**  
 Email: [ap.support@nsc.com](mailto:ap.support@nsc.com)

**National Semiconductor Japan Customer Support Center**  
 Fax: 81-3-5639-7507  
 Email: [jpn.feedback@nsc.com](mailto:jpn.feedback@nsc.com)  
 Tel: 81-3-5639-7560