

HORIZONTAL CLAMPS

H50 SERIES MODEL H50/1B



Arm:
The spindle position is adjustable along the arm.

Base:
Straight.

Nominal Holding Force:
50 daN

Weight:
0.033 Kg

Supplied complete with:
MB0520 Setscrew & nuts.
FW05/09 Flanged washers.

See "Accessories" for other items.

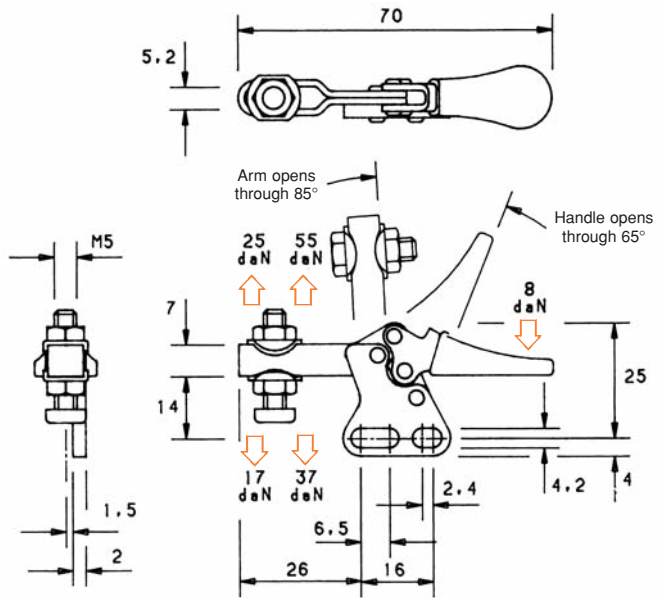

H50 SERIES MODEL H50/2B



Arm:
The spindle position is adjustable along the arm.

Base:
Flanged.

Nominal Holding Force:
50 daN

Weight:
0.036 Kg

Supplied complete with:
MB0520 Setscrew & nuts.
FW05/09 Flanged washers.

See "Accessories" for other items.

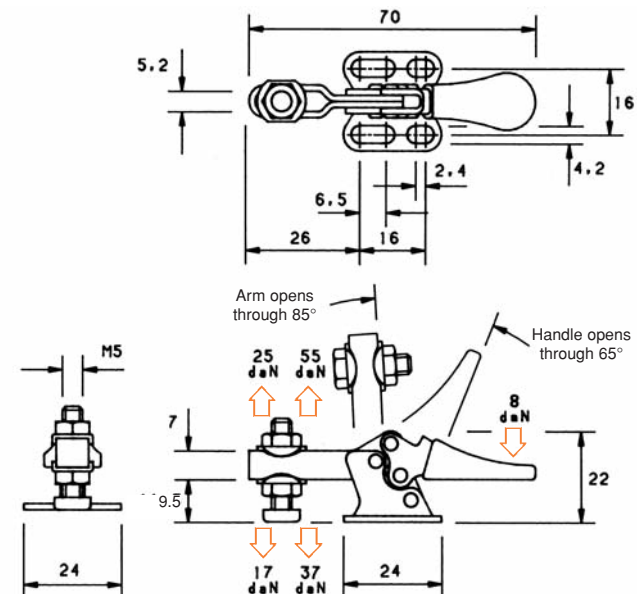

H50 SERIES MODEL H50/2BSS



Arm:
The spindle position is adjustable along the arm.

Base:
Flanged.

Nominal Holding Force:
50 daN

Weight:
0.036 Kg

Supplied complete with:
Setscrew & nuts.
Flanged washers.

Material:
BS 304 S15.

