

LOC	DIST	REVISIONS			
P	LTR	DESCRIPTION	DATE	OWN	APVD
G	14	P6	REVISED PER ECO-11-011757	08JUN11	HMR DR

AMP
WIRE RANGE
12-10 AWG
SOLID OR STRANDED

- 1 STAMP AMP 12-10* APPROX AS SHOWN
- 2 MAXIMUM LENGTH DOES NOT INCLUDE MANUFACTURING TABS
- 3 TIN PLATE .00254[.000100] MIN THK PER ASTM B545
- 4 BLACK OXIDE PER MIL-F-495
- 5 UL LISTED E13288, 12-10 AWG STRANDED.
- 6 MATERIAL; COPPER PER ASTM B-152 ANNEALED
- 7 FINISH: TIN/LEAD (60/40) PLATE, .000100 MIN THK PER SAE-AMS-P-81728
- 8 CSA CERTIFIED LR7189, 12-10 AWG SOLID OR STRANDED
- 9 PRELIMINARY - NOT FOR PRODUCTION
- 10 GOLD PLATE 0.00127[.000050] MIN EXT THK PER ASTM B488, TYPE 1, CODE C OVER NICKEL PLATE 0.00127[.000050] MIN EXT THK PER SAE AMS QQ-N-290 OVER Cu FLASH PER SAE AMS 2418.

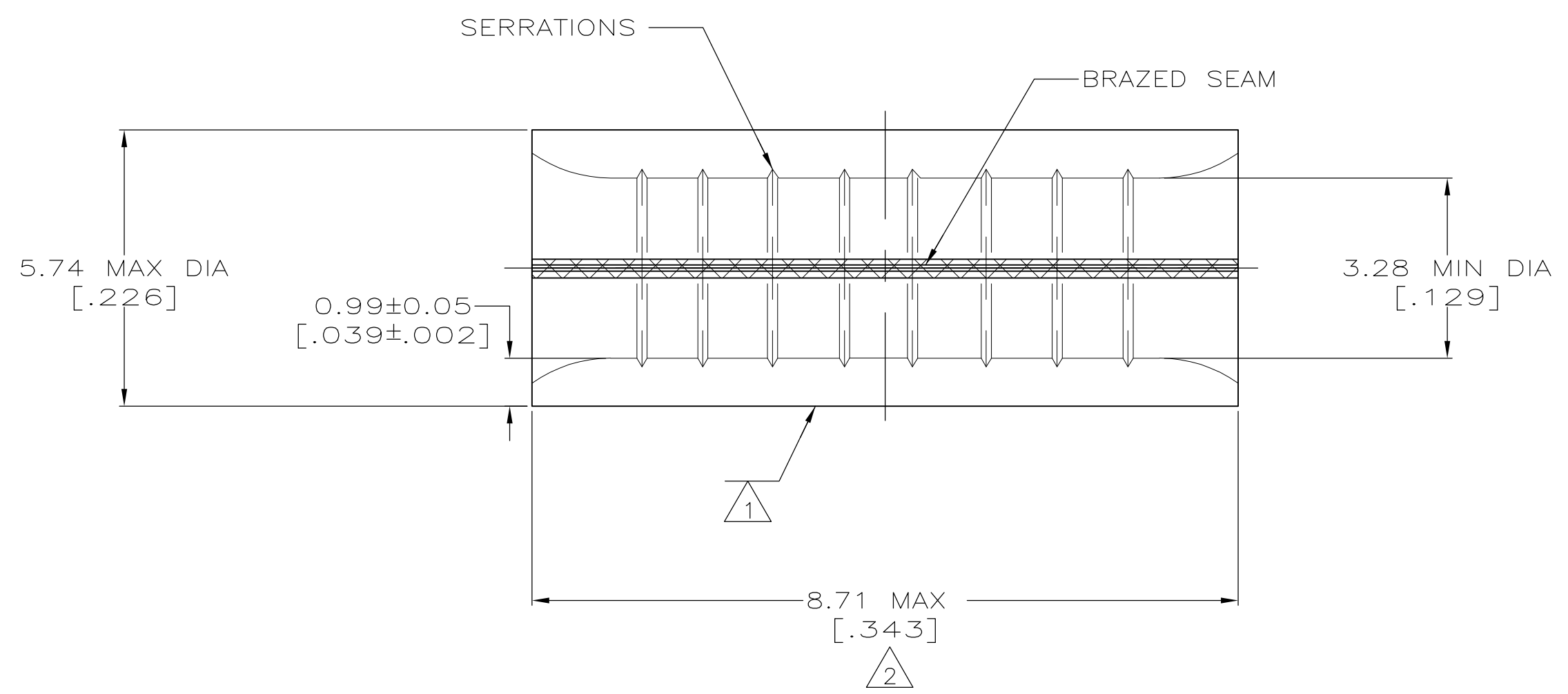

TEMP-RANGE	APPROVALS	FINISH	QTY	PACKAGE TYPE	PART NO
170°C	5 8	3	10	LOOSE PIECE, BAG	8-34138-3
170°C	5 8	3	50	LOOSE PIECE, BOX	8-34138-2
260°C	----	10	500	LOOSE PIECE	34138-4
170°C	----	7	500	LOOSE PIECE	34138-3
170°C	----	4	500	LOOSE PIECE	34138-1
170°C	5 8	3	500	LOOSE PIECE	34138

**AMP INCORPORATED
CUSTOMER SERVICE SYSTEMS**

FOR ADDITIONAL PRODUCT INFORMATION OR COPIES OF DRAWINGS AND TECHNICAL DOCUMENTS	PRODUCT INFORMATION CENTER 1-800-522-6752	MAX RECOMMENDED OPERATING TEMPERATURE: SEE TABLE
FOR APPLICATION TOOLING INFORMATION	TOOLING ASSISTANCE CENTER 1-800-722-1111	VOLTAGE RATING: N/A
FOR ORDER ENTRY	1-800-526-5142	CIRCULAR MIL AREA: 2.62-6.64mm ² [5,180-13,100] STRANDED

THIS DRAWING IS A CONTROLLED DOCUMENT FOR AMP INCORPORATED. IT IS SUBJECT TO CHANGE AND THE CONTROLLING ENGINEERING ORGANIZATION SHOULD BE CONTACTED FOR THE LATEST REVISION.

THIS DRAWING IS A CONTROLLED DOCUMENT.

DIMENSIONS: MM[INCHES]	TOLERANCES UNLESS OTHERWISE SPECIFIED: 0 PLC ± - 1 PLC ± - 2 PLC ± - 3 PLC ± - 4 PLC ± - ANGLES ± ± -	DWN TA BRINKMAN 4-14-93 CHK DA PATTERSON 4-14-93 APVD DA PATTERSON 4-14-93	STE TE Connectivity
MATERIAL - 6	FINISH SEE NOTES	NAME SPLICE, PARALLEL, SOLISTRAND	SIZE CAGE CODE DRAWING NO RESTRICTED TO A2 00779 G-34138
CUSTOMER DRAWING		WEIGHT -	SCALE 10:1 SHEET 1 of 1 REV P6