

Product Overview

The 3021 "BuckPuck" LED Power Modules are a line of true current regulated drivers for LEDs. Unlike standard power supplies, which deliver a fixed voltage to the output, the 3021 is designed to vary the output voltage as required to deliver a constant current to the LED(s), reliably and with stability.

The line of 3021 drivers exhibit high efficiency and require no external current limiting resistors or additional heat sinking. A fast response current-sensing circuit makes the 3021 ideal for applications where flashing or strobe operation of the LED(s) is required.

A wide range of options are available including AC or DC input, external dc analog voltage intensity control, TTL/CMOS logic level on/off control, and set-and-forget internal current limiting.

The standard units are fully potted in an extremely small form factor* and are provided with a simple 7 pin SIP connection for through-hole PCB mounting or use with the optional wiring harness.

The 3021's built-in regulated 5V reference can provide output to power logical circuitry or microprocessor, eliminating the need for an additional power supply on the circuit board.



(4) 03021-D-E-700 BUCKPUCKs mounted to LuxDrive's 4016 QuadPuck 4-Channel DMX Driver Interface

Features

- AC or DC input power up to 32V (24V_{rms}AC)
- 350mA, 500mA, 700mA, or 1.0A constant current output
- Extremely small form factor* (0.83"x0.83"x0.43")
- Simple 7-pin SIP connection for through-hole PCB mounting or use with optional wiring harness
- External analog/digital intensity control (TTL compatible)
- Optional external potentiometer intensity control (0-100%)
- Optional on-board trim adjustment (40-110%)
- Output short circuit protection up to 15 seconds
- Output open circuit protection
- Pulse and strobe capable (control input)
- Built-in 5V reference/output to power logic circuitry or μ Processor

Typical Applications

- Solar & Landscape Lighting
- Architectural Lighting
- Track Lighting
- Automotive & Marine Lighting
- Portable Lighting & Flashlights
- Point of Purchase Lighting
- Desk & Reading Lamps
- Signal & marker Lighting
- Flashing & Strobe Lighting
- Cabinet & Display Case Lighting
- Sign & Channel Letters
- Much More...

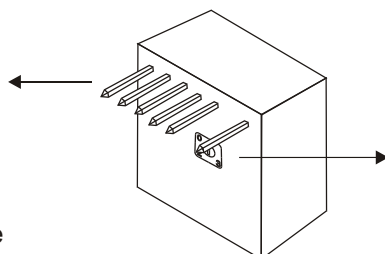

* - Units can be designed for OEM applications - Contact LuxDrive for more information

Part Number Identification Table

Part Number	DC	AC	On-Board Trim	Ctrl Pin	Ref Pin	Ext. Pot.
3021-A-N-XXXX	yes	yes	no	no	no	no
3021-A-E-XXXX	yes	yes	no	yes	yes	yes
3021-A-I-XXXX	yes	yes	yes	yes	yes	yes
3021-D-N-XXXX	yes	no	no	no	no	no
3021-D-E-XXXX	yes	no	no	yes	yes	yes
3021-D-I-XXXX	yes	no	yes	yes	yes	yes

XXXX - Output current rating in milliamperes (mA): 350, 500, 700, 1000 or special order factory custom rating

Absolute Maximum Ratings

Input Voltage, DC Model. 32V
 Input Voltage, AC Model 24V_{rms}
 Output Voltage 32V
 Control Pin Voltage 10V
 Reference regulator current (5V_{DC}) 20mA

PINOUT

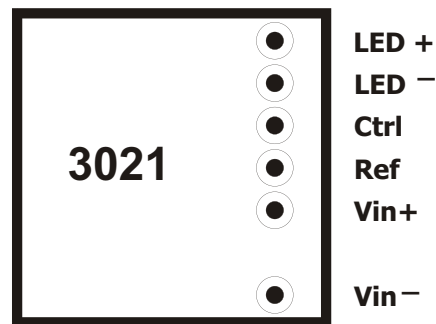

Bottom View

Typical Characteristics

Output tolerance (within specified temp. range) ±5%
 Efficiency 95%
 Input Voltage Minimum 5V_{DC} 7V_{rms}
 Input Margin (350mA unit¹, add to LED Vf MAX). 1V_{DC} 2V_{rms}

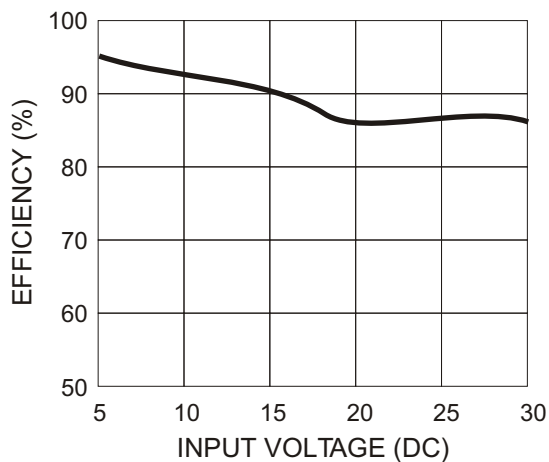

Figure 1.
Efficiency vs. Vin

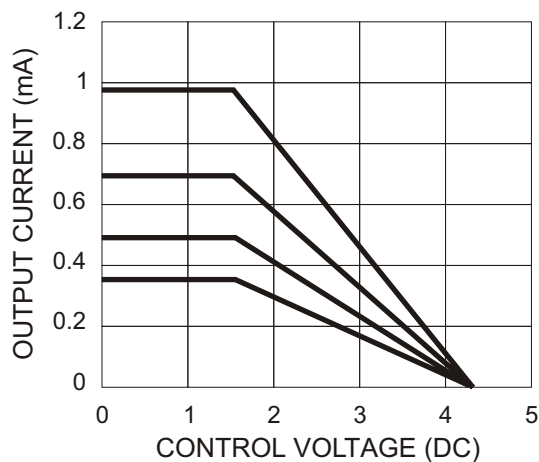

Figure 2.
Output current vs. control voltage

1 - There is an efficiency penalty for powering an AC device with DC (vs. a DC-only module).
 1 - Margin increases with higher current units.

Specifications

Output current, 3021-x-x-350	350mA ²
Output current, 3021-x-x-500	500mA ²
Output current, 3021-x-x-700	700mA ²
Output current, 3021-x-x-1000	1000mA ²
Control Pin, adjustment threshold	1.65 V ±5%
Control Pin, shutoff threshold	4.2 V ±5%
Control Pin, on time	15 μs
Control Pin, off time	15 μs
Control Pin, input impedance	1k ohm
Reference voltage.	5 V _{DC} ±5% ³
Optional trim pot adjustment range	40%-110% ³
External pot adjustment range.	0%-100% ³
Maximum flash frequency	10 kHz
Minimum strobe pulse width	50 μs
Strobe turn-on / turn-off time	<10 μs
Quiescent current (no load or control pin high)	<500 μA
Operating temperature	-40+85°C
Storage temperature	-40+125°C

Application Information

Description

The 3021 Wide Range LED Power Module is a high efficiency dc to dc converter which delivers a fixed output current by varying the output voltage as required to maintain the specified current . A fast response current-sensing circuit permits the unit to be used in applications where flashing or pulsing of the LEDs is required. Several options are available allowing for use with many types of LEDs and in a variety of operating modes

Fixed Current Drive

The fixed output versions of the 3021 are designed to supply their rated current to one or more LED junctions. For example, a 350 mA rated unit will drive up to six Luxeon* I LEDs connected in series. Due to the nature of the buck regulator, the input voltage must always be higher than the total forward voltage drop of the LED junction(s) connected in series (1.0V for DC models, ~2.0V for AC models). Thus, for a series string of six junctions having an average forward drop of 3.5V, the required minimum input voltage will be 21V_{DC}. A standard 24V_{DC} power supply is a good choice for this application.

Figures 3 through 6 show 700mA and 1000mA rated units driving multiple LEDs. Note that parallel strings of LEDs can be driven directly with no additional circuitry required to insure current sharing. The nature of the LEDs themselves will provide good current sharing if the parallel strings comprise 3 or more junctions each. Figure 7 shows a 700mA unit driving a Luxeon* V. This could also represent a 350mA unit driving a Luxeon* I, a 1000mA unit driving Luxeon* III, or a 500mA unit driving a Nichia Jupiter**.

* - Luxeon is a registered trademark of Lumileds Corporation
** - Jupiter is a registered trademark of Nichia Chemical Corporation

2 - Measured with single emitter; output current drops slightly with additional series junctions to limit maximum power dissipation.
3 - When V_{IN} > 5.25V_{DC}

Adjustable Current - On-Board Control - "I" Model

Where the ability to adjust the output current to an intermediate value is required, all output current ratings are available with an on-board potentiometer. This permits the output current to be varied from approximately 40% to 110% of the rated value. When measuring the output is required to determine a particular set point, the following method is recommended:

Temporarily place a 0.1 ohm, 1% resistor in series with the LED+ output.
Read the voltage across the 0.1 ohm resistor.
The voltage, in millivolts X 10, will equal the output current in mA.

Because there is a small, high-frequency component in the 3021 output, many multi-meters will give an incorrect reading when used in the current mode. It has been found that the method described above yields a far more accurate measurement.

The potentiometers used for the on-board adjustable units are rated for a limited number of rotations (typically 100) and are intended for "set it and forget it" applications. Where frequent adjustments of output current are needed, the use of units with external adjustment capabilities is recommended.

Adjustable Current - External Control - "E" Model

Figures 9 and 10 show external adjustment configurations. Both use a 5Kohm, linear taper potentiometer. In Figure 9, the potentiometer is connected between the internal 5V_{DC} reference (Ref) output and the control (Ctrl) input. When using this configuration, it is important that V_{in} be 5.25V_{DC} or higher. Figure 10 shows the control potentiometer being powered by an external 5V_{DC} source. When using an external power source for the potentiometer, the source ground must be common to the LED- output pin. In either configuration, connect the potentiometer such that clockwise rotation increases the resistance. Note that because the current through the potentiometer is less than 5mA, a low power potentiometer may be used.

External On/Off Control

Where a manual on/off control is desired, the potentiometer in Figures 9 and 10 may be replaced by a pushbutton or toggle switch. The output current will be zero when the switch is closed. Figures 11 and 12 show external dimming control combined with on/off control. The circuit in Figure 12 uses a 2N4403 or equivalent PNP switching transistor.

External Pulse/Strobe Control

Figures 13 and 14 show two methods for low speed pulsing or high speed flashing operation. In Figure 13, a TTL/CMOS logic signal is applied directly to the control (Ctrl) input of the 3021. The output current will be zero when the control signal is high. Note that the input needs to source a minimum of 4.75V_{DC} into a 1Kohm input impedance. Also, as is the case with a dc control signal, the logic input ground should to be common to the LED-output terminal.

Figure 14 shows an inverted input configuration using a 2N4401 or other NPN switching transistor. In this case, a logic high will cause the output to be "on". In either configuration, the rise and fall times of the output will be 15µsec or less. A pulse frequency up to 10kHz may be used.

Microprocessor Control

Figure 15 shows a typical interface for a microchip PIC or similar μ controller. The reference output provides the operating voltage for the processor (up to 20mA current).

Other Control Applications

In addition to the configurations described above, the 3021 may also be driven by a D to A converter. As in the cases above, the analog control signal should have its ground common to LED-. Figure 2 shows the effective control range of the analog input signal.

Using DC Input Voltage on AC Input Units

Units with the AC input option for V_{in} can be powered from a DC source by connecting the power source to the input terminals. Note that the input for an AC input configured unit is not polarity sensitive. The only difference in operation is that the minimum input voltage must be increased from $2V_{dc}$ to $4V_{dc}$ above the required output voltage.

Connections

In all cases, the LEDs being driven should be located as close to the 3021 LED output as possible. When the use of long leads is required, use heavier gauge wire. For strobe or pulse applications, a wire length not exceeding 6" should be used to maintain accurate timing. All control wires should also be less than 6" in length.

The power input wires/traces should also be kept short. Where DC input units are located more than 18" from the source, a 220 μ F, 50V capacitor should be placed across the input terminals as shown in Figure 13.

For applications where the use of header pins is inconvenient, a mating connector with 6" leads is available as an accessory.

- 03021HN** - Harness for "N" type (4-wire)
- 03021HE** - Harness for "E" & "I" type (6-wire)
- 03021HEP** - Harness for "E" & "I" w/pot (6-wire w/pot)

Application Figures

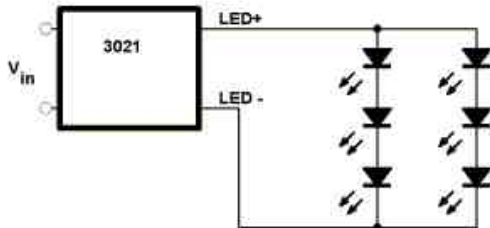

Figure 3.
700mA unit driving LumiLEDs
6-ring (VIN ≥ 12VDC)

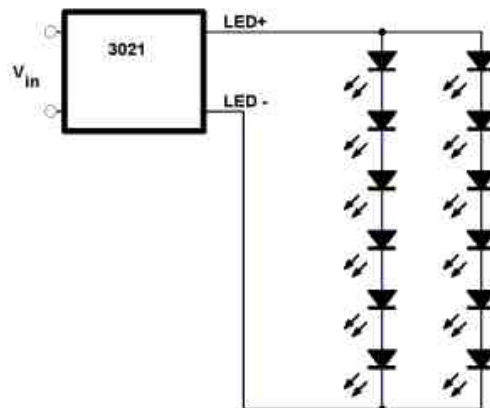

Figure 4.
700mA unit driving LumiLEDs
12-ring (VIN ≥ 24VDC)

* - Luxeon is a registered trademark of LumiLEDs Corporation

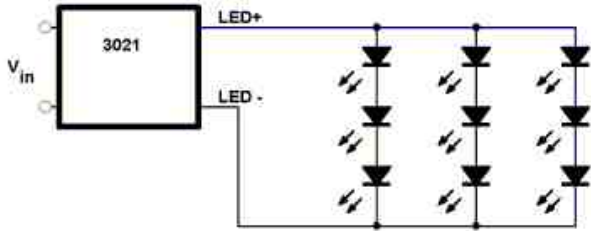

Figure 5.
1000mA unit driving nine Luxeon® I emitters
(VIN ≥ 12VDC)

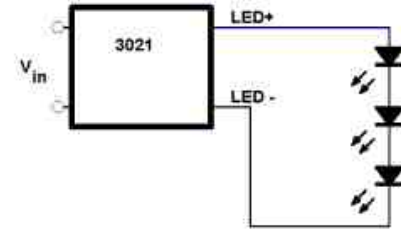

Figure 6.
1000mA unit driving three Luxeon® III emitters
(VIN ≥ 12VDC)

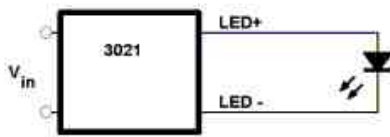

Figure 7.
700mA unit driving one Luxeon® V emitter
(VIN ≥ 12VDC)

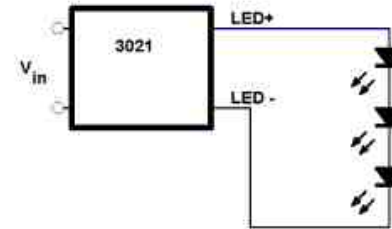

Figure 8.
700mA unit driving three Luxeon® V emitters
(VIN ≥ 24VDC)

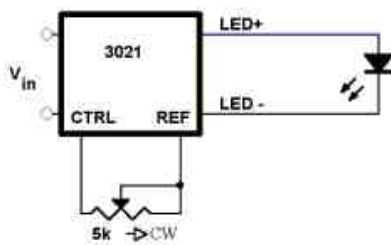

Figure 9.
External potentiometer using internal reference

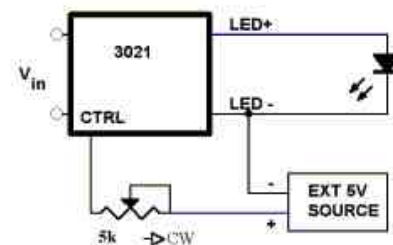

Figure 10.
External potentiometer using external voltage source

* - Luxeon is a registered trademark of LumiLEDs Corporation

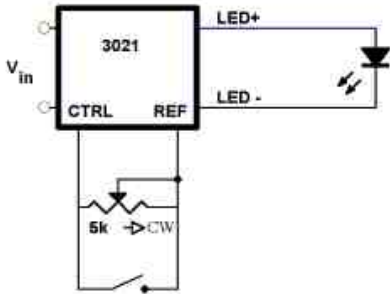

Figure 11.
External dimming plus ON/OFF control with switch closure

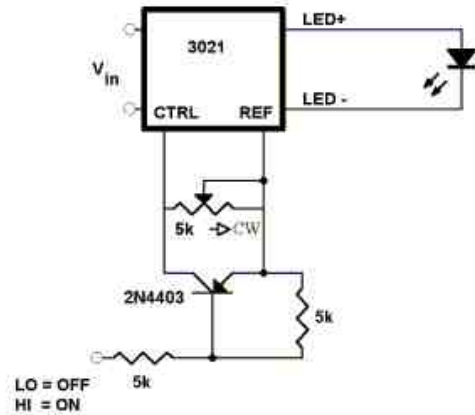

Figure 12.
External dimming plus ON/OFF control with logic level input

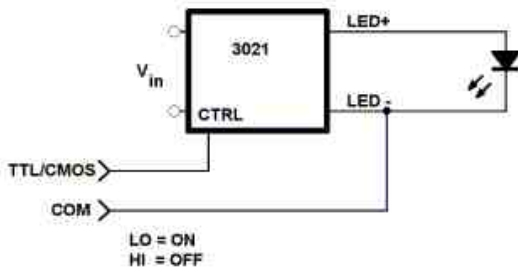

Figure 13.
Pulse/Strobe input 5V=OFF

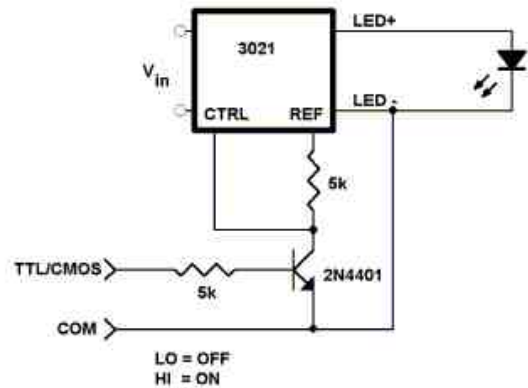

Figure 14.
Pulse/Strobe input 5V=ON

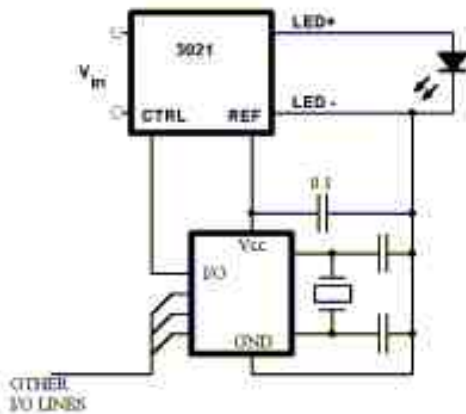

Figure 15.
Interface to PIC or other microcontroller

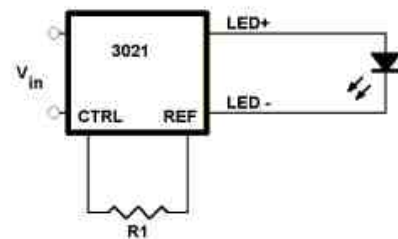

Figure 16.
Using resistor for fixed current reduction
Output is approximately: $\%I_{OUT} = R1/50$

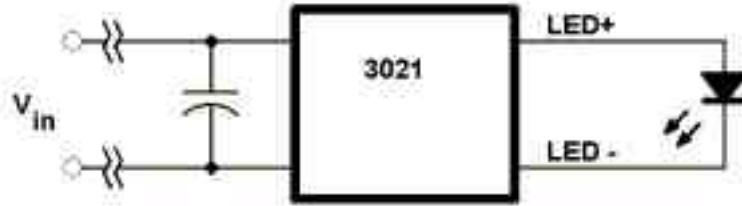
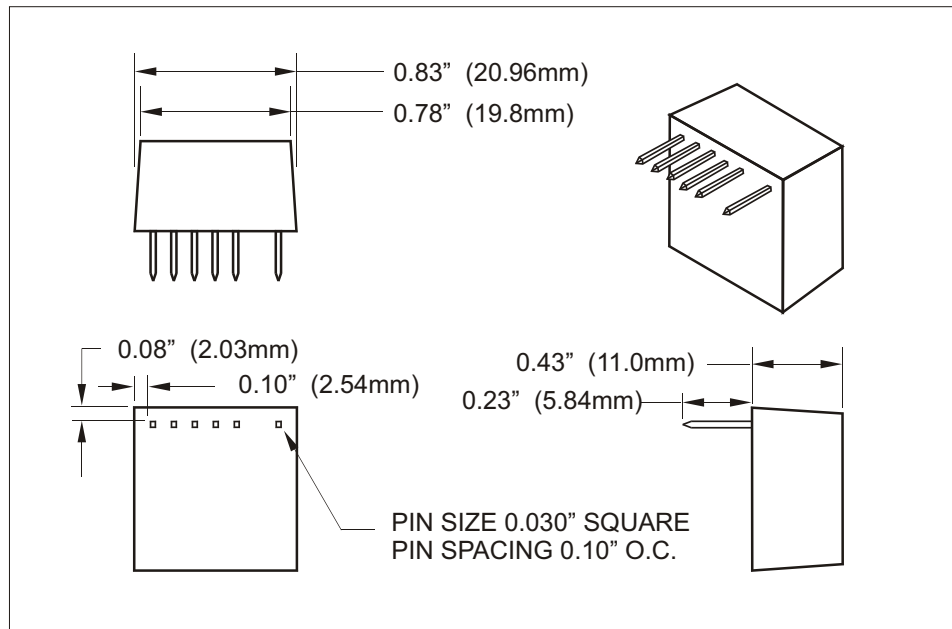

Figure 17.
Place a capacitor across the input terminals when the distance to the DC power source is greater than 18 inches
DO NOT USE A CAPACITOR WHEN USING AC POWER!

Physical Dimensions



Shown approximately actual size