

# Flow Sensor with IO-Link

## FXFF005

Part Number

weFlux<sup>2</sup> InoxSens



- A single sensor for flow and temperature
- FDA compliant
- Measurement independent of flow direction and installation position
- Ready for Industry 4.0 with IO-Link 1.1

weFlux<sup>2</sup> Flow Sensors simultaneously measure flow velocity and the temperature of aqueous liquids regardless of position and direction of flow. Advantage: The number of measuring points and the diversity of sensor variants are cut in half, and greatest possible flexibility is assured for installation in closed piping systems. Either 2 switching outputs or 1 switching output and 1 analog output are available depending on application requirements. The outputs can be configured as desired via IO-Link in order to flexibly adapt the sensors to the respective application.

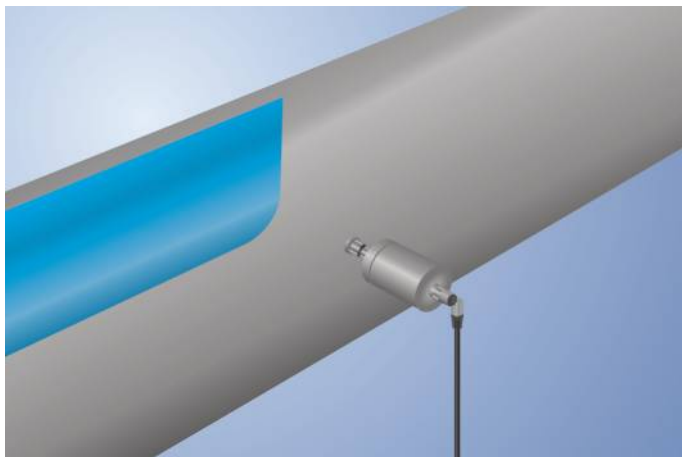

### Technical Data

#### Sensor-specific data

Measuring Range	10...400 cm/s
Temperature of the medium, flow measurement	0...125 °C**
Temperature of the medium, temperature measurement	-25...150 °C
Adjustable Range	10...400 cm/s
Medium	Water
Measuring error	≤ 2 %
Response time in case of temperature jump	10 s

#### Environmental conditions

Ambient temperature	-25...80 °C
Storage temperature	-25...80 °C
Mechanical Strength	25 bar
EMC	DIN EN 61326-1
Shock resistance per DIN IEC 68-2-27	30 g / 11 ms
Vibration resistance per DIN IEC 60068-2-6	5 g (10...2000 Hz)

#### Electrical Data

Supply Voltage	12...32 V DC
Current Consumption (U <sub>b</sub> = 24 V)	< 40 mA
Switching Outputs	2
Analog Outputs	1
Analog Output	0...10 V/4...20 mA
Response Time	1...5 s
Switching Output/Switching Current	± 100 mA
Switching Output Voltage Drop	< 2 V
Current Output Load Resistance	(U <sub>b</sub> -U <sub>bmin</sub> )/0,02A
Current Load Voltage Output	≤ 20 mA
Short Circuit Protection	yes
Reverse Polarity Protection	yes
Protection Class	III
Interface	IO-Link V1.1
IO-Link Version	1.1

#### Mechanical Data

Setting Method	IO-Link
Housing Material	1.4404
Material in contact with media	1.4404
Degree of Protection	IP68/IP69K *
Connection	M12 × 1; 4-pin
Process Connection	Clamp diameter: 50,5 mm
Process Connection Length (PCL)	49 mm
Probe Length (PL)	32 mm

Analog output switchable to flow or temperature	●
Switching output switchable to flow or temperature	●
Switchable to NC/NO	●
Configurable as PNP/NPN/Push-Pull	●

Connection Diagram No.	139
Suitable Connection Technology No.	21

\* Tested by wenglor

\*\* The sensors were calibrated and specified for the medium water. Technically, the sensors are suitable for a medium temperature of up to -25 °C. To achieve a temperature below 0 °C, a different medium must be added to the water. This leads to a different measurement result, which is why a use under 0 °C must be tested individually for the mixture used.

### Complementary Products

IO-Link Master  
Software

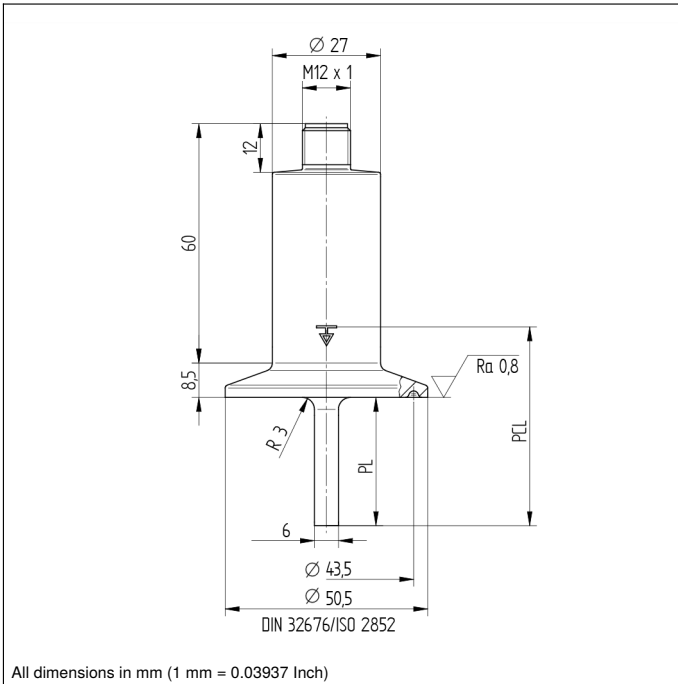

All dimensions in mm (1 mm = 0.03937 Inch)

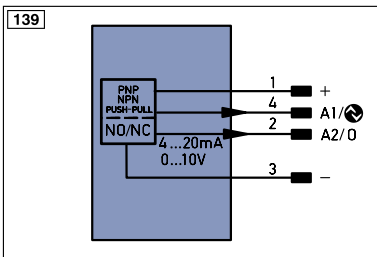

### Legend

+	Supply Voltage +	PT	Platinum measuring resistor	ENa	Encoder A
-	Supply Voltage 0 V	nc	not connected	ENb	Encoder B
~	Supply Voltage (AC Voltage)	U	Test Input	AMIN	Digital output MIN
A	Switching Output (NO)	U	Test Input inverted	AMAX	Digital output MAX
Ā	Switching Output (NC)	W	Trigger Input	AOK	Digital output OK
V	Contamination/Error Output (NO)	O	Analog Output	SY In	Synchronization In
ṽ	Contamination/Error Output (NC)	O-	Ground for the Analog Output	SY OUT	Synchronization OUT
E	Input (analog or digital)	BZ	Block Discharge	LI	Brightness output
T	Teach Input	AW	Valve Output	M	Maintenance
Z	Time Delay (activation)	a	Valve Control Output +	rsv	reserved
S	Shielding	b	Valve Control Output 0 V		
RxD	Interface Receive Path	SY	Synchronization		
TxD	Interface Send Path	E+	Receiver-Line		
RDY	Ready	S+	Emitter-Line		
GND	Ground	±	Grounding		
CL	Clock	SnR	Switching Distance Reduction		
E/A	Output/Input programmable	Rx+/-	Ethernet Receive Path		
IO-Link	IO-Link	Tx+/-	Ethernet Send Path		
PoE	Power over Ethernet	Bus	Interfaces-Bus A(+)/B(-)		
IN	Safety Input	La	Emitted Light disengageable		
OSSD	Safety Output	Mag	Magnet activation		
Signal	Signal Output	RES	Input confirmation		
Bl..D+/-	Ethernet Gigabit bidirect. data line (A-D)	EDM	Contactorm Monitoring		
EN0 r542	Encoder 0-pulse 0-0 (TTL)	ENAr542	Encoder A/Ā (TTL)		
		ENBr542	Encoder B/B̄ (TTL)		

### Wire Colors according to DIN IEC 757

BK	Black
BN	Brown
RD	Red
OG	Orange
YE	Yellow
GN	Green
BU	Blue
VT	Violet
GY	Grey
WH	White
PK	Pink
GNYE	Green/Yellow

