

# PPD. Clamps, heavy-duty series

pneumatic drive, steel



## MATERIAL

Weldable zinc-plated steel.

## BODY

Black coated spheroidal cast iron.

## HEXAGON-SOCKET HEAD SCREWS WITH COUNTERSINK FOR CYLINDER SUPPORT

Hardened steel.

## CYLINDER SUPPORT BUSHINGS

Hardened steel.

## ROTATING PINS AND SEEGER RINGS

Ground and hardened steel.

## MAXIMUM WORKING PRESSURE

6 bars.

## MAX WORKING TEMPERATURE

80°C.

## FEATURES AND APPLICATIONS

All articulated joints are lubricated with special grease. PPD. pneumatic clamps are designed for easy disassembly. Indeed, rotation pins are fixed through seeger rings, which allows to disassemble and change the clamping lever to satisfy specific application requirements.

The magnetic cylinder, equipped with limit switches type PSW. (see page 1506) (to be ordered separately) gives drive and/or control impulses while active.

Using a lubrication filter assembly is necessary for the cylinder to work properly for a long time, whereas flow regulators are recommended to guarantee long life of mechanical components.

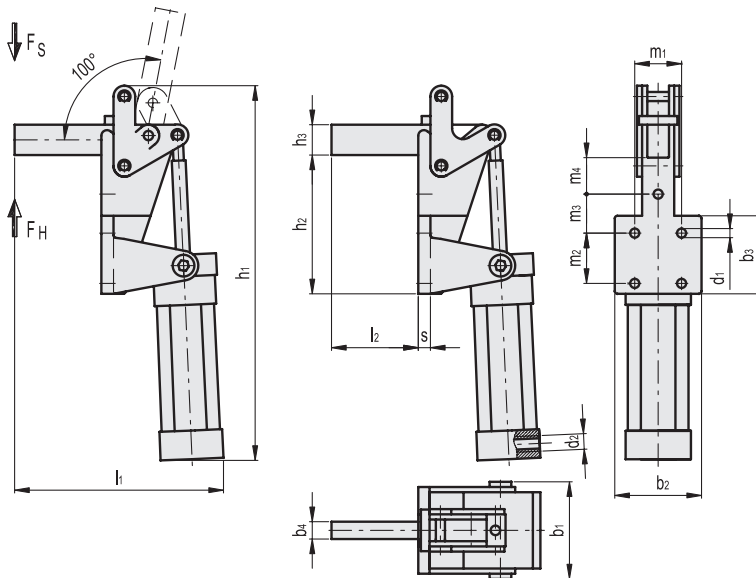
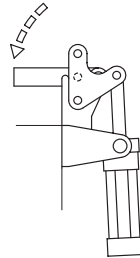

Code	Description	b1	b2	b3	b4	d1	d2	h1	h2	h3	l1	l2	m1	m2	m3	m4	s	FH [N]*	FS [N]#	⚖
GG.AO605	PPD.1000-EPVM	102	90	80	20	10.5	G1/4	355	130	25	215	80	50	50	-	-	13	10000	3400	6500
GG.AO625	PPD.2000-EPVM	112	100	90	20	13	G3/8	424	157	35	246.5	100	54	58	45	45	14	20000	4320	9000

\* Holding force.

# Clamping force ~4 bar



Models all rights reserved in accordance with the law. Always mention the source when reproducing our drawings and photos.

11/2019



Toggle clamps

