

# IGR202

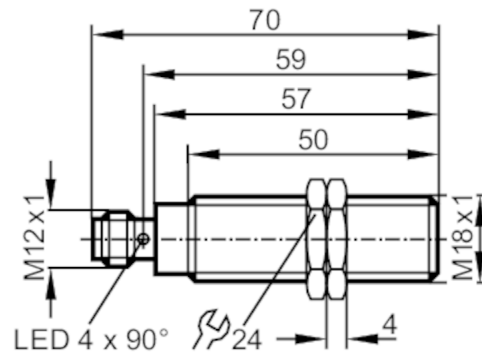

## Inductive full-metal sensor

IGK3006BANKG/AM/SC/US-104-DNS



### Product characteristics

Electrical design		NPN
Output function		normally open
Sensing range	[mm]	6
Housing		threaded type
Dimensions	[mm]	M18 x 1 / L = 70

### Application

Special feature		Gold-plated contacts; Increased sensing range; Full-metal housing; Magnetic-field immune; anti-spatter
Application		Use in welding applications
Pressure rating	[bar]	100
Note on pressure rating		sensing face
Magnetic-field immune		yes; (pulse duration of the welding current: < 200 ms)

### Electrical data

Operating voltage	[V]	10...36 DC
Current consumption	[mA]	< 20
Protection class		III
Reverse polarity protection		yes

### Outputs

Electrical design		NPN
Output function		normally open
Max. voltage drop switching output DC	[V]	2.5
Permanent current rating of switching output DC	[mA]	100
Switching frequency DC	[Hz]	2
Short-circuit protection		yes
Type of short-circuit protection		pulsed
Overload protection		yes

# IGR202



## Inductive full-metal sensor

IGK3006BANKG/AM/SC/US-104-DNS

Detection zone		
Sensing range	[mm]	6
Operating distance	[mm]	0...4.9
Increased sensing range		yes
Accuracy / deviations		
Correction factor		steel: 1 / stainless steel: 0.7 / brass: 0.5 / aluminium: 0.3 / copper: 0.1
Hysteresis	[% of Sr]	1...20
Operating conditions		
Ambient temperature	[°C]	0...85
Protection		IP 67
Tests / approvals		
EMC	EN 61000-4-2 ESD	4 kV CD / 8 kV AD
	EN 61000-4-3 HF radiated	10 V/m
	EN 61000-4-4 Burst	2 kV
	EN 61000-4-6 HF conducted	10 V
	EN 55011 emission	class B
Impact resistance		1 J
MTTF	[years]	1293
UL approval	Ta	-25...70 °C
	Enclosure type	Type 1
	voltage supply	Limited Voltage/Current
	UL Approval no.	A012
	File number UL	E174191
Mechanical data		
Weight	[g]	54.1
Housing		threaded type
Mounting		flush mountable
Dimensions	[mm]	M18 x 1 / L = 70
Thread designation		M18 x 1
Materials		housing: stainless steel (1.4404 / 316L) anti-spatter; sensing face: stainless steel (1.4404 / 316L) anti-spatter; plug: PA; lock nuts: stainless steel (1.4404 / 316L) anti-spatter
Full-metal housing		yes
Displays / operating elements		
Display	switching status	4 x 90° LED, yellow
	operation	1 x LED, green
Accessories		
Accessories (supplied)		lock nuts: 2
Remarks		
Pack quantity		1 pcs.
Electrical connection - plug		
Connector: 1 x M12; Contacts: gold-plated		

# IGR202



## Inductive full-metal sensor

IGK3006BANKG/AM/SC/US-104-DNS



### Connection

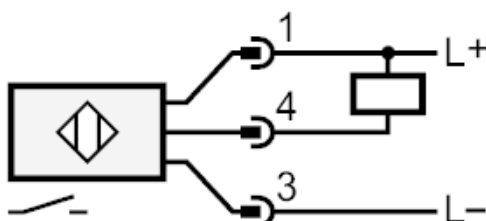

### Diagrams and graphs

#### Installation

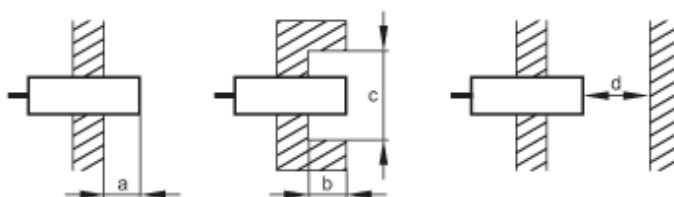

[mm]	a	b	c (Ø)	d
Fe	0	0	-	18
Al	13	20	54	18

