

# OGT101

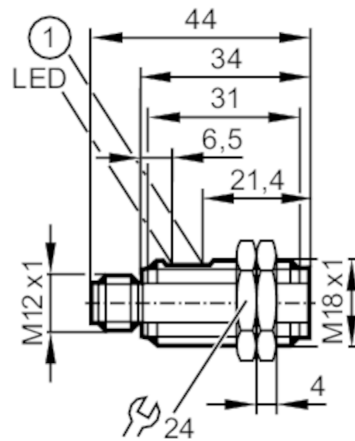

## Diffuse reflection sensor

OGT-DPKG/US



- 1 potentiometer  
receiver in upper lens  
transmitter in lower lens



### Product characteristics

Type of light	red light
Housing	threaded type
Dimensions [mm]	M18 x 1 / L = 44

### Application

Function principle	Diffuse reflection sensor
--------------------	---------------------------

### Electrical data

Operating voltage [V]	10...30 DC
Current consumption [mA]	20
Protection class	III
Reverse polarity protection	yes
Type of light	red light
Wave length [nm]	645

### Outputs

Electrical design	PNP
Output function	dark-on mode
Max. voltage drop switching output DC [V]	2.5
Permanent current rating of switching output DC [mA]	200
Switching frequency DC [Hz]	1000
Short-circuit protection	yes
Overload protection	yes

# OGT101



## Diffuse reflection sensor

OGT-DPKG/US

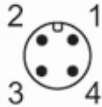
Detection zone		
Range	[mm]	10...400; (white paper 200 x 200 mm 90% remission)
Range adjustable		yes
Max. light spot diameter	[mm]	25
Light spot dimensions refer to		at maximum range
Monitoring range final value	[mm]	70...400
Operating conditions		
Ambient temperature	[°C]	-25...60
Protection		IP 65; (in conjunction with a corresponding connector)
Tests / approvals		
EMC		EN 60947-5-2
MTTF	[years]	901
Mechanical data		
Weight	[g]	15.1
Housing		threaded type
Dimensions	[mm]	M18 x 1 / L = 44
Thread designation		M18 x 1
Materials		housing: ABS
Lens material		PMMA
Displays / operating elements		
Display	switching status	1 x LED, yellow
Operating elements		potentiometer
Accessories		
Accessories (supplied)		lock nuts: 2 x
Remarks		
Pack quantity		1 pcs.
Electrical connection		
Connector: 1 x M12		
		



## Diffuse reflection sensor

OGT-DPKG/US

### Connection

