

Typ-Nr. R14629 R14638

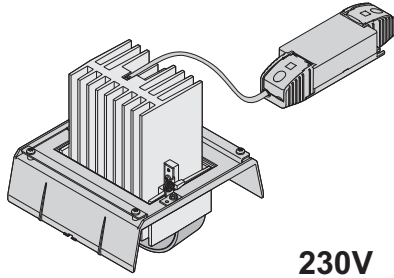

230V

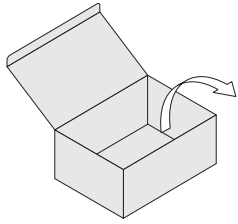
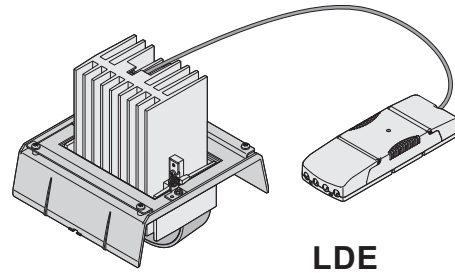

LDE

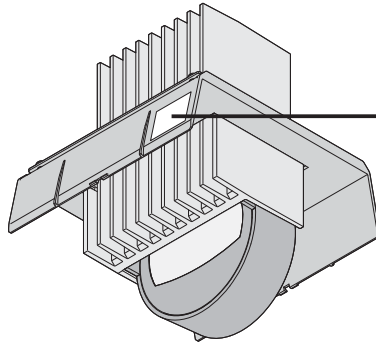
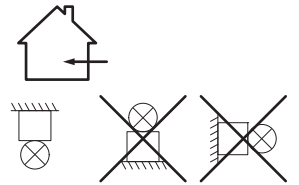

UK CA	Thorn Lighting Limited Durhamgate Spennymoor Co. Durham DL16 6HL UK	Zumtobel Lighting GmbH Schweizerstrasse 30 A - Dornbirn	
Mod		
SerW LED.....		
Typ 220-240V 50/60Hz		



Zumtobel
Info on (non-) replaceability

EN: The servicing of the control gear in this luminaire should only be undertaken by the manufacturer or his service agent or a similar qualified person.



EN: The light source of this luminaire is not replaceable; when the light source reaches its end of life the whole luminaire shall be replaced.

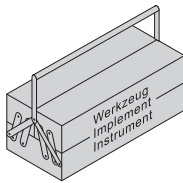
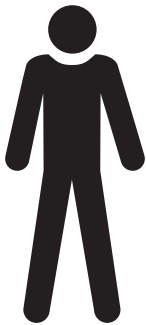

DE Die Montage und Inbetriebnahme darf nur von autorisiertem Fachpersonal durchgeführt werden.

NL De montage en inbedrijfstelling mogen enkel door erkend vakpersoneel worden uitgevoerd.

EN Installation and commissioning may only be carried out by authorized specialists.

NO/SE Monteringen och idrifttagandet får endast företas av auktoriserad fackpersonal.

FR L'installation et la mise en service doivent obligatoirement être effectuées par des techniciens.

FI Asennuksen ja käyttöönnoton saa tehdä vain auktorisoitu ammattihenkilöstö.

IT Montaggio ed avviamento devono essere eseguiti solo da personale specializzato.

ES El montaje y la puesta en marcha sólo puede ser realizado por personal especializado autorizado.

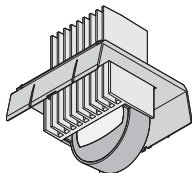

FR Le luminaire sert uniquement à l'éclairage et doit être installé conformément aux prescriptions nationales en matière d'installation. Toute autre utilisation ou installation est considérée comme "non conforme".

NO/SE Armaturen är uteslutande avsedd för belysning och ska installeras i enlighet med de nationella installationsbestämmelserna. All annan användning eller montering gäller som "icke ändamålsenlig".

DE Die Leuchte dient ausschließlich der Beleuchtung und ist entsprechend den nationalen Errichtungsbestimmungen zu installieren. Eine andere Nutzung oder ein anderer Einbau gilt als „nicht bestimmungsgemäß“.

IT L'apparecchio è destinato esclusivamente all'illuminazione e va installato in conformità alle leggi nazionali in vigore. Un altro impiego o un diverso tipo di montaggio non è considerato conforme alle disposizioni.

FI Valaisin on tarkoitettu ainoastaan valaistuskäyttöön, ja se on asennettava kansallisten määräysten mukaan. Muu käyttö tai muu asennus katsotaan sopimuksenvastaiseksi käytöksi.

EN The luminaire is used exclusively for lighting and is to be installed in accordance with the national installation regulations. Any other use or installation is regarded as "not according to instructions".

NL De lamp dient uitsluitend voor de verlichting en dient conform de nationale bouwbepalingen te worden geïnstalleerd. Een ander gebruik of een andere inbouw is niet conform.

ES La lámpara está destinada exclusivamente a la iluminación y debe ser instalada de acuerdo con las pertinentes normas nacionales. Cualquier otro uso o instalación no se considerará "previsto por la norma".

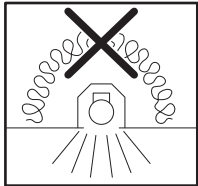

DE Leuchte darf nicht mit Wärmedämmung abgedeckt werden.

GB Luminaire not suitable for covering with thermally insulating material.

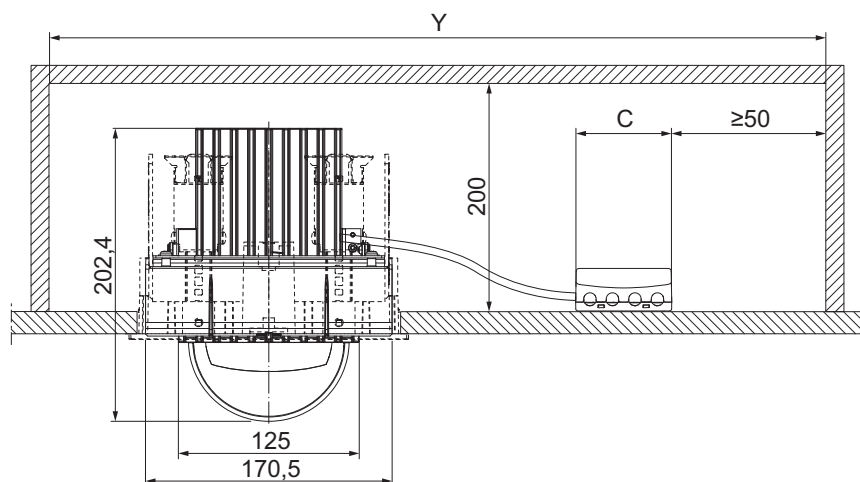
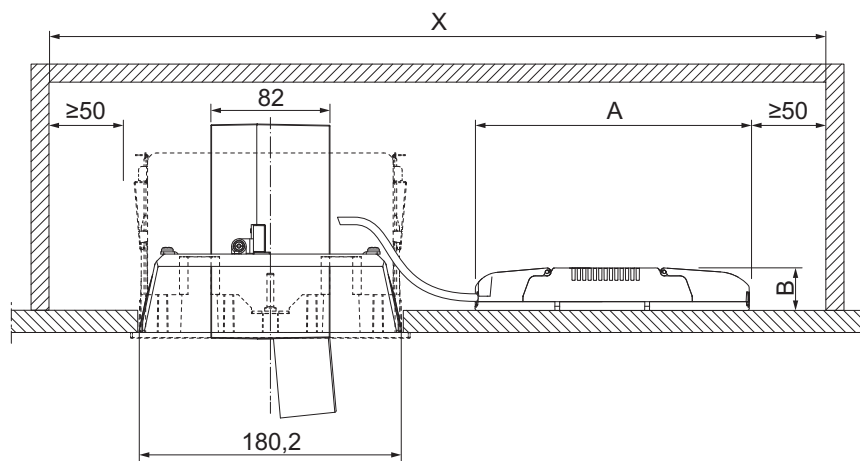

	A (mm)	B (mm)	C (mm)
230V	145	29	42
LDE	200	31	74

		X (mm)	Y (mm)
INT M LC	1 x	700	700
INT M LC	2 x	700	1000
INT M LC	3 x	700	1400

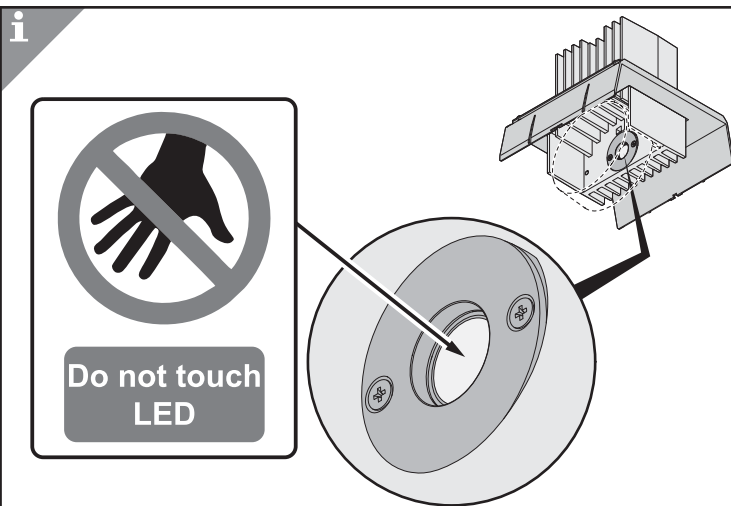
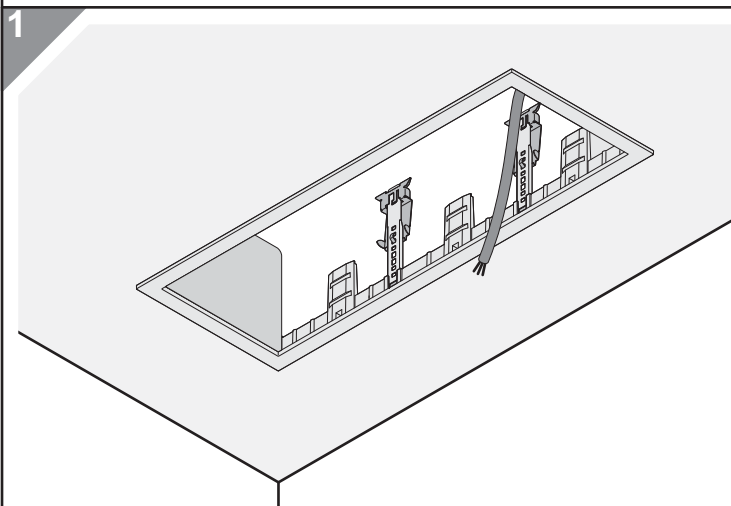

2 230V

~~Durchschleifen - Looping-in (feed through)
Câblage traversant (le luminaire)
Cablaggio passante (il luminaire)
Doorlussen
Överkoppling - Enlazado~~

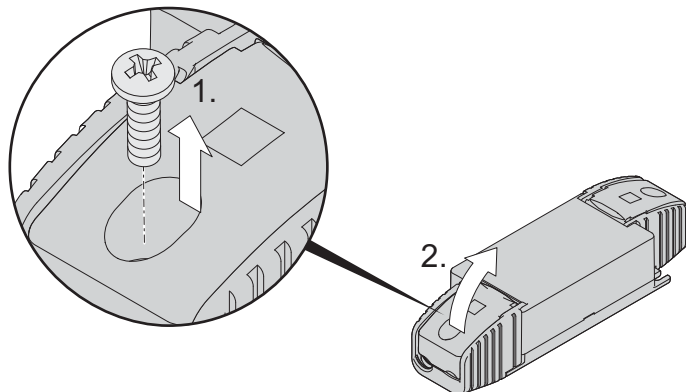
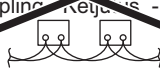

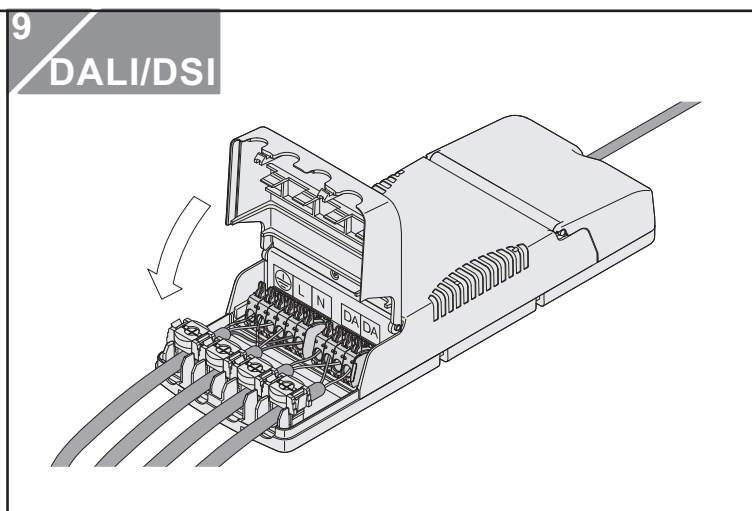
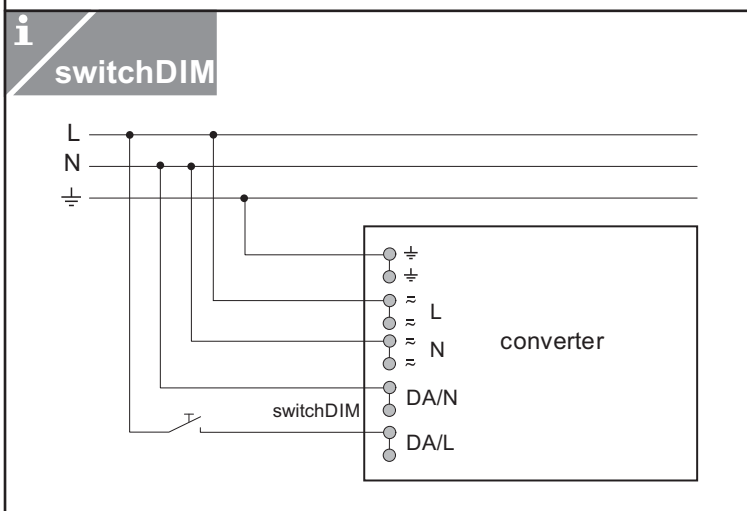
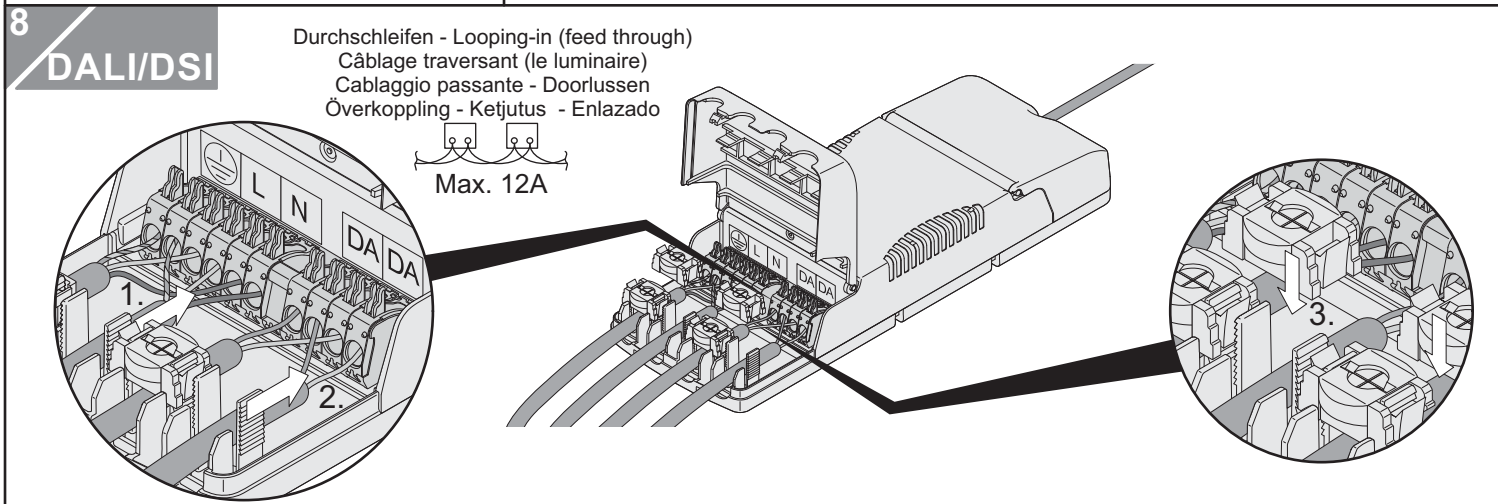
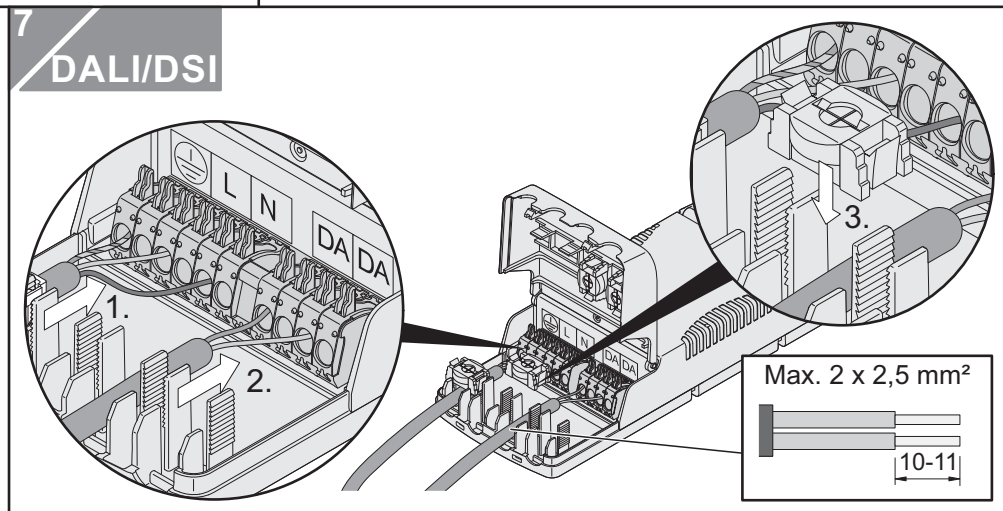
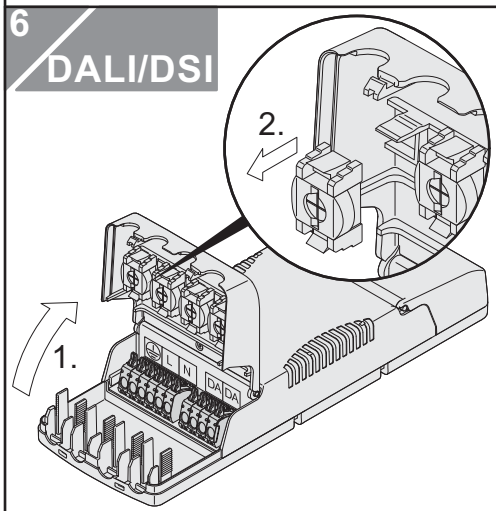
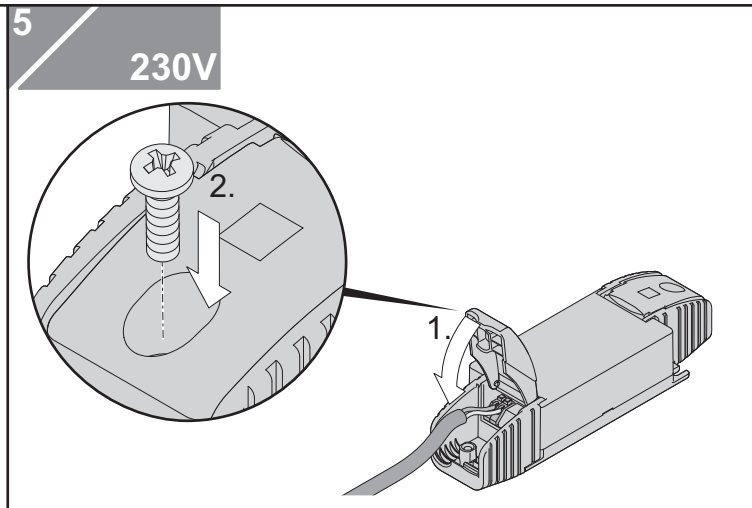
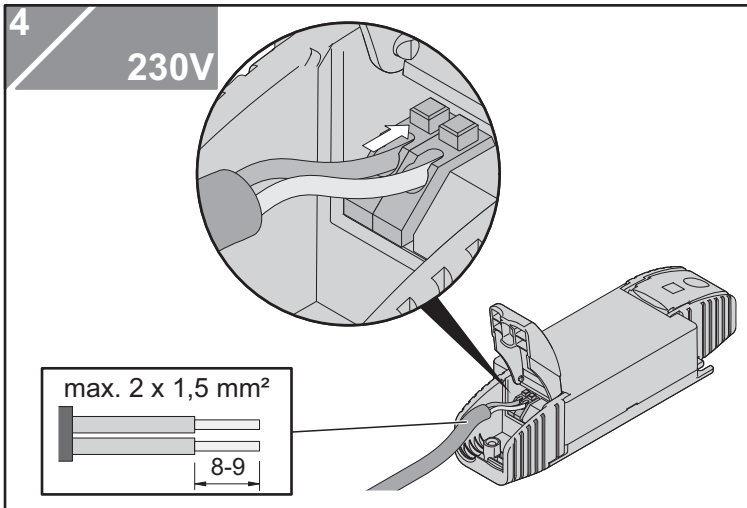

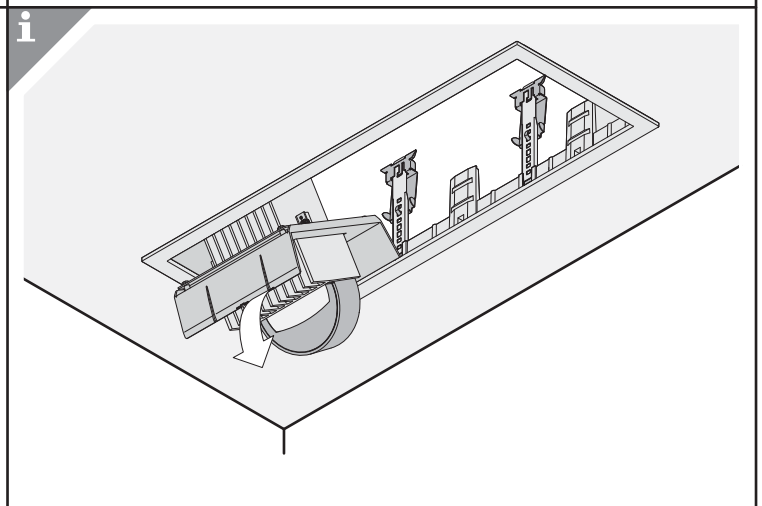
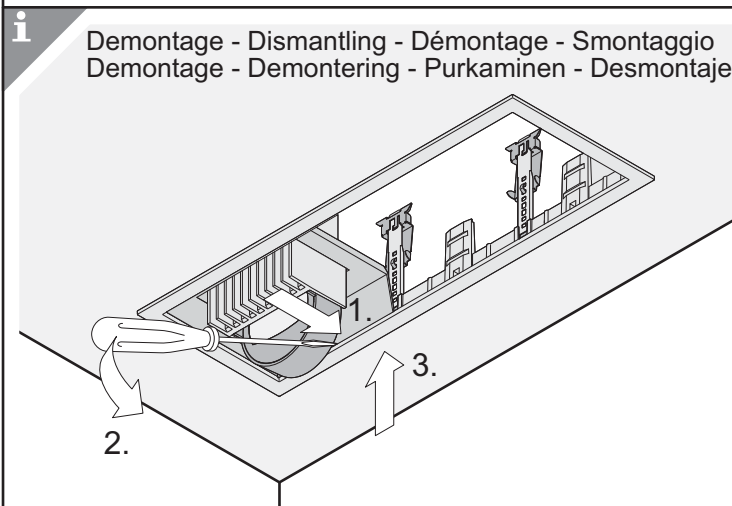
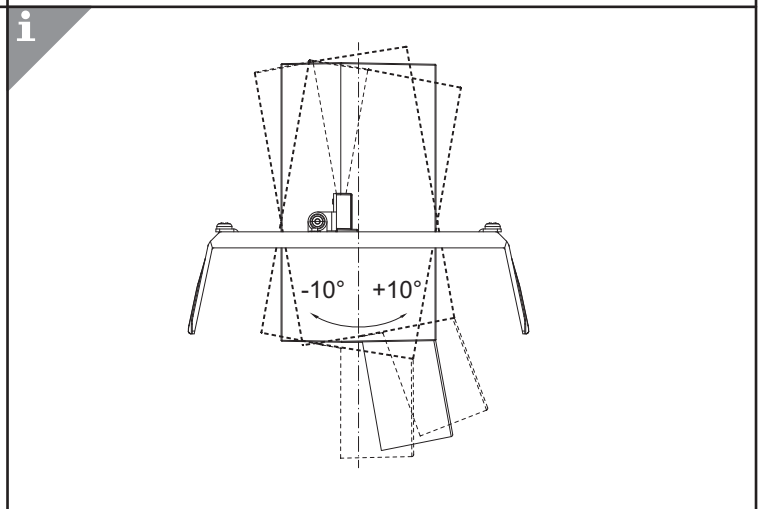
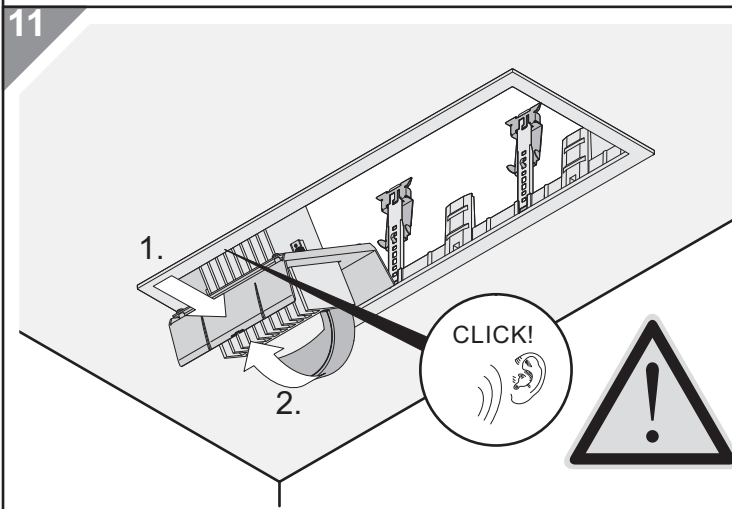
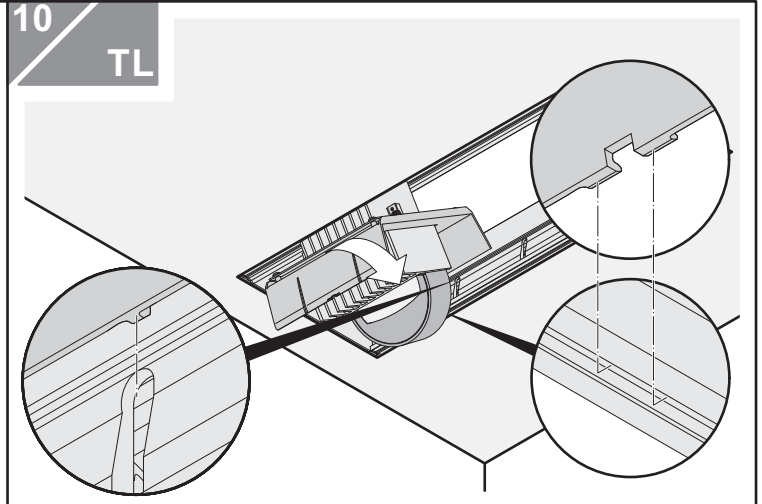
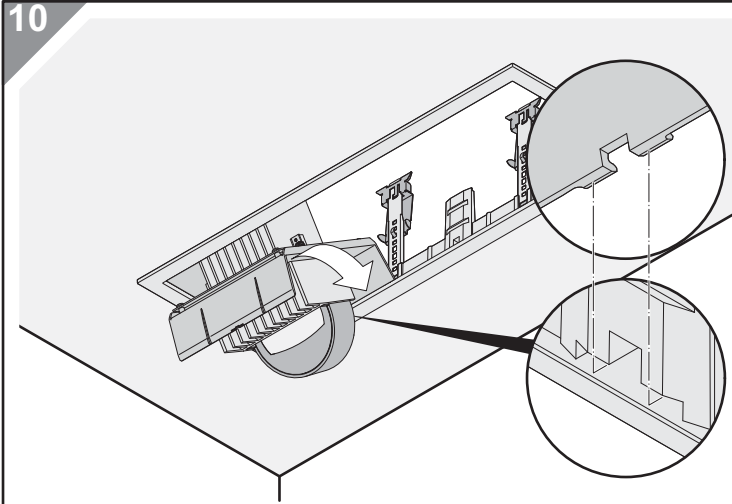

Zubehör - Accessory - Accessoire éventuel - Accessori
Toebehoren - Tillbehör - Lisätarvike - Accesorios

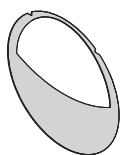

60200109 LED MASK-S LC BK
60200111 LED MASK-S LC WH

DE Technische Änderungen vorbehalten.
EN Specifications subject to change without notice.
FR Modifications techniques sans préavis.
IT Modifiche tecniche senza preavviso.
NL Technische wijzigingen voorbehouden.
NO/SE Med forbehold om tekniske endringer.
FI Oikeudet teknisiin muutoksiin pidätetään.
ES Modificaciones técnicas sin preaviso.