

ARTESYN LPX40/60 ENCLOSURE

LPX40 will fit the LPX4X power supplies

LPX60 will fit the LPX6X power supplies

Advanced Energy's Artesyn LPX40/60 is an optional enclosure that is sold separately from the power supply. This aims to serve applications requiring physical protection from harmful environmental factors. It is recommended that effect on the power supply cooling should be checked once enclosure is used.

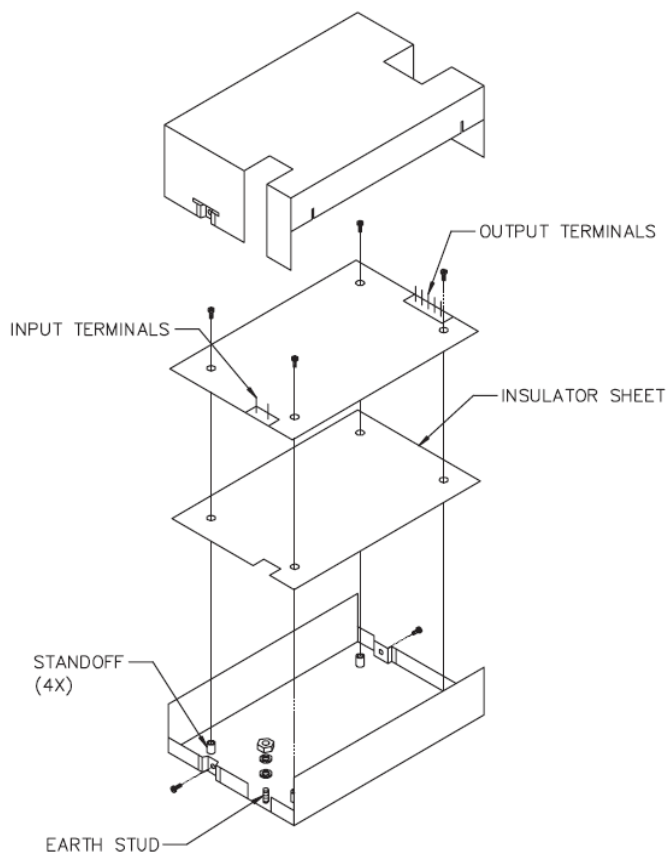

AT A GLANCE

MATERIALS

- 1 Base
- 1 Cover
(top and sides perforated)
- 6 M3 x 6mm screws with captive washer
- 1 M4 nut
- 1 M4 star washer
- 1 M4 spring washer
(Above 3 x M4 for earth stud)
- 1 Plastic insulator sheet



INSTALLATION INSTRUCTIONS AND NOTES

1	Place the insulator over the chassis as shown.
2	Place the power supply over the insulator as shown.
3	Align the power supply to the chassis standoff.
4	Secure 4 pan head screws with washer provided with in kit as shown.
5	Place the cover over the chassis.
6	Align the cover to the U-bracket countersink holes.
7	Secure 2 countersink screws provided with in kit as shown.
8	Overall dimensions: LPX4X: 5.9 (150) x 3.86 (98) x 1.50 (38) LPX6X: 5.9 (150) x 3.86 (98) x 1.97 (38)
9	Base plate has three sets of customer mountings: a. Bottom mounting (4X) M3 inserts. Max. screw penetration 0.0787 (2mm) b. Side mounting (2X) 4mm clear holes plus 2 keyways. (See keyway detail) c. Side mounting (4X) M3 inserts. Max. screw penetration 0.236 (6mm)
10	Ensure insulator is correctly fitted in base under PCB to maintain safety creepage and clearances.
11	Ensure base is firmly connected to supply earth via the earth stud marked Ⓧ.
12	When using this enclosure, ensure that relevant safety standards (e.g. EN60950) are complied with, in respect to creepage and clearance distances, and distances through insulation.
13	All dimensions are in inches (mm).

MECHANICAL DRAWING

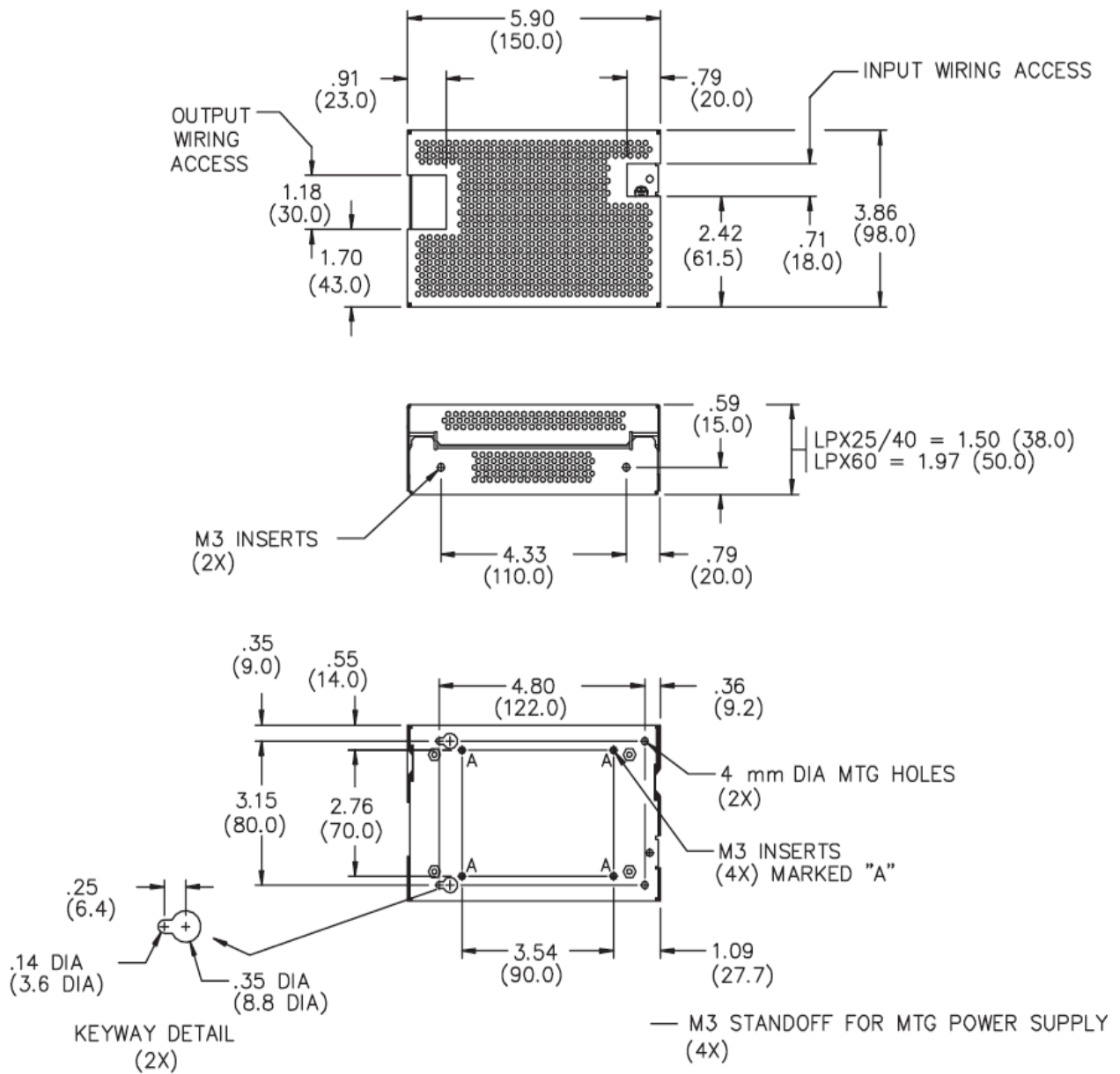



For international contact information,
visit advancedenergy.com.

powersales@aei.com (Sales Support)
productsupport.ep@aei.com (Technical Support)
+1 888 412 7832

ABOUT ADVANCED ENERGY

Advanced Energy (AE) has devoted more than three decades to perfecting power for its global customers. AE designs and manufactures highly engineered, precision power conversion, measurement and control solutions for mission-critical applications and processes.

Our products enable customer innovation in complex applications for a wide range of industries including semiconductor equipment, industrial, manufacturing, telecommunications, data center computing, and medical. With deep applications know-how and responsive service and support across the globe, we build collaborative partnerships to meet rapid technological developments, propel growth for our customers, and innovate the future of power.

PRECISION | POWER | PERFORMANCE

Specifications are subject to change without notice. Not responsible for errors or omissions. ©2021 Advanced Energy Industries, Inc. All rights reserved. Advanced Energy®, AE® and Artesyn™ are U.S. trademarks of Advanced Energy Industries, Inc.