

Device for ATORN torque recorder DM2
with a torque of 500 Nm



Application

For mounting on e.g. a workbench. Enables torque testing directly at the workplace.

Version

- Flange plate with 1/2 inch square cutout
- Adapter plate with support bearing
- includes spacers, screws and mounting

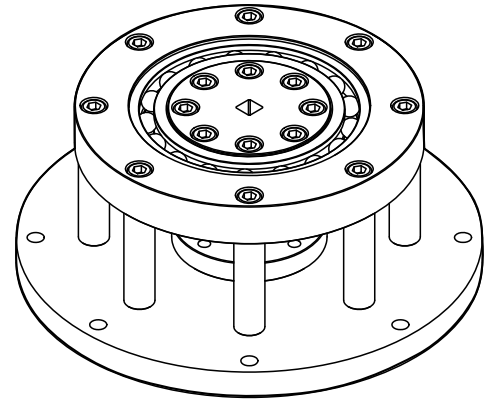

Art. No.	44817 745
Bore diameter	11 mm
Number of drill holes	8 PCS
Flange diameter	300 mm
Total height	124 mm
Reference circle diameter	275 mm
Square width	12.5 mm

EAN-Code

40502937 15712