



### DC/DC CONVERTER

- 24V DC-Input
- Isolated 24Vdc Output
- NEC Class 2 Output
- Quick-connect Spring-clamp Connection Terminals
- Efficiency up to 90.5%
- Width only 32mm
- Full Power Between -25°C and +60°C
- Soft-start Function Included
- Minimal Inrush Current Surge
- Reverse Input Polarity Protection
- 3 Year Warranty

### PRODUCT DESCRIPTION

The Dimension CD-Series offer DIN rail DC/DC converters in the 92-120W output power range in a very compact housing. These DC/DC converters are allowed to run with a battery or similar sources or can also be used to refresh and stabilize the 24Vdc on the end of long cable runs. The basic units include all the essential basic functions while the -S1 version is equipped with quick-connect spring clamp terminals, a DC-OK-contact which monitors the output and an input-low-relay-contact. The -L1 version additionally fulfills the NEC Class 2 requirements. All devices except the CD5.241-L1 have a PowerBoost of 20% incorporated. This extra power can even be used continuously up to +45°C.

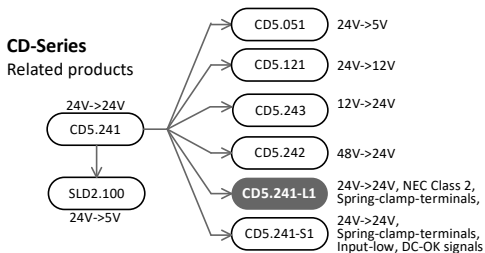

### SHORT-FORM DATA

Output voltage	DC 24V	
Adjustment range	not adjustable	
Output current	3.8A	NEC Class 2
Output power	92W	
Output ripple	< 50mVpp	20Hz to 20MHz
Input voltage	DC 24V	
Input voltage range	14.4 to 32.4Vdc	full specified
Input current	typ. 4.25A	at 24Vdc input
Input inrush current	typ. 1.2A peak	
Efficiency	90.5%	at 24Vdc input
Losses	9.7W	at 24Vdc input
Temperature range	-25°C to +70°C	operational
Derating	0W/°C	+60 to +70°C
Hold-up time	typ. 7ms	at 24Vdc input
Dimensions	32x124x102mm	WxHxD
Weight	425g / 0.94lb	

### ORDER NUMBERS

DC/DC Converter	<b>CD5.241-L1</b>	Standard unit
Accessory	ZM1.WALL	Wall mount bracket
	ZM10.WALL	Wall mount bracket
	ZM11.SIDE	Side mount bracket
	YRM2.Diode	Redundancy module

### MAIN APPROVALS

For details and the complete approval list, see chapter 18



UL 508



ATEX



UL 60950-1



Marine



Class I Div 2



Marine



### INDEX

	Page		Page
1. Intended Use .....	3	20. Physical Dimensions and Weight.....	19
2. Installation Instructions .....	3	21. Accessories .....	20
3. Input Voltage .....	5	21.1. ZM1.WALL - Wall mounting bracket .....	20
4. Soft-start and Input Inrush Current Surge .....	6	21.2. ZM10.WALL - Wall/Panel Mount Bracket .....	20
5. Output .....	7	21.3. ZM11.SIDE - Side mounting bracket .....	21
6. Hold-up Time.....	8	21.4. YRM2.DIODE Redundancy Module.....	21
7. Efficiency and Power Losses.....	9	22. Application Notes .....	22
8. Functional Diagram.....	10	22.1. Peak Current Capability .....	22
9. Front Side and User Elements.....	10	22.2. Back-feeding Loads .....	22
10. Terminals and Wiring.....	11	22.3. Inductive and Capacitive Loads.....	22
11. Lifetime Expectancy .....	12	22.4. External Input Protection.....	23
12. MTBF.....	12	22.5. Requirements for the Supplying Source.....	23
13. EMC .....	13	22.6. Parallel Use to Increase Output Power .....	23
14. Environment.....	14	22.7. Parallel Use for Redundancy .....	23
15. Protection Features .....	15	22.8. Series Operation .....	24
16. Safety Features.....	15	22.9. Charging of Batteries .....	24
17. Dielectric Strength .....	16	22.10. Use in a Tightly Sealed Enclosure .....	24
18. Approved, Fulfilled or Tested Standards.....	17	22.11. Mounting Orientations .....	25
19. Regulatory Product Compliance.....	18		

The information presented in this document is believed to be accurate and reliable and may change without notice. Some parts of this unit are patent by PULS (US patent No 091662,063, Des. 424,529, ...).

No part of this document may be reproduced or utilized in any form without permission in writing from PULS GmbH.

### TERMINOLOGY AND ABBREVIATIONS

<b>PE and  symbol</b>	PE is the abbreviation for <b>Protective Earth</b> and has the same meaning as the symbol  .
<b>Earth, Ground</b>	This document uses the term "earth" which is the same as the U.S. term "ground".
<b>t.b.d.</b>	To be defined, value or description will follow later.
<b>DC 24V</b>	A figure displayed with the AC or DC before the value represents a nominal voltage with standard tolerances included. E.g.: DC 12V describes a 12V battery disregarding whether it is full (13.7V) or flat (10V)
<b>24Vdc</b>	A figure with the unit (Vac) at the end is a momentary figure without any additional tolerances included.

## 1. INTENDED USE

This device is designed for installation in an enclosure and is intended for commercial use, such as in industrial control, process control, monitoring and measurement equipment or the like. Do not use this device in equipment where malfunction may cause severe personal injury or threaten human life.

If this device is used in a manner outside of its specification, the protection provided by the device may be impaired.

## 2. INSTALLATION INSTRUCTIONS

### **WARNING** Risk of electrical shock, fire, personal injury or death.

- Turn power off before working on the device and protect against inadvertent re-powering.
- Do not open, modify or repair the device.
- Use caution to prevent any foreign objects from entering into the housing.
- Do not use in wet locations or in areas where moisture or condensation can be expected.
- Do not touch during power-on, and immediately after power-off. Hot surface may cause burns.

### **Obey the following installation instructions:**

This device may only be installed and put into operation by qualified personnel.

This device does not contain serviceable parts. The tripping of an internal fuse is caused by an internal defect.

If damage or malfunction should occur during installation or operation, immediately turn power off and send unit to the factory for inspection.

Install device in an enclosure providing protection against electrical, mechanical and fire hazards.

Install the device onto a DIN rail according to EN 60715 with the input terminals on the bottom of the device. Other mounting orientations require a reduction in output current.

Make sure that the wiring is correct by following all local and national codes. Use appropriate copper cables that are designed for a minimum operating temperature of 60°C for ambient temperatures up to +45°C, 75°C for ambient temperatures up to +60°C and 90°C for ambient temperatures up to +70°C. Ensure that all strands of a stranded wire enter the terminal connection.

The device is designed for pollution degree 2 areas in controlled environments. No condensation or frost is allowed.

The enclosure of the device provides a degree of protection of IP20. The enclosure does not provide protection against spilled liquids.

The isolation of the device is designed to withstand impulse voltages of 1.5kV according to IEC 60664-1.

The input can be powered from batteries or similar DC sources. The voltage between the input terminals and ground must not exceed 60Vdc continuously. The ripple voltage in the low frequency range between 50Hz and 10kHz must be negligible when used in marine applications.

The input must be powered from a PELV or SELV source or an "Isolated Secondary Circuit" in order to maintain a SELV or PELV output.

Check for correct input polarity. The device will not operate when the voltage is reversed.

A disconnecting means shall be provided for the input of the device. The device is designed as "Class of Protection III" equipment according to IEC 61140. A PE (ground) connection is not required. However, connecting the chassis ground terminal to ground can be beneficial to gain a high EMI immunity.

The device is designed for convection cooling and does not require an external fan. Do not obstruct airflow and do not cover ventilation grid!

The device is designed for altitudes up to 5000m (16400ft). Above 2000m (6560ft) a reduction in output current is required.

Keep the following minimum installation clearances: 40mm on top, 20mm on the bottom, 5mm left and right side. Increase the 5mm to 15mm in case the adjacent device is a heat source. When the device is permanently loaded with less than 50%, the 5mm can be reduced to zero.

The device is designed, tested and approved for branch circuits up to 50A without additional protection device. If an external fuse is utilized, do not use circuit breakers smaller than 10A B- or 8A C-Characteristic to avoid a nuisance tripping of the circuit breaker.

The maximum surrounding air temperature is +70°C (+158°F). The operational temperature is the same as the ambient or surrounding air temperature and is defined 2cm below the device.

The device is designed to operate in areas between 5% and 95% relative humidity.

### Installation Instructions for Hazardous Location Areas

The device is suitable for use in Class I Division 2 Groups A, B, C, D locations and for use in Group II Category 3 (Zone 2) environments.

Classification: ATEX: EPS 08 ATEX 1 142 X, II 3G EX ec nC IIC T4 Gc / IECEx EPS 14.0001X

### **WARNING** EXPLOSION HAZARDS!

Substitution of components may impair suitability for this environment.

Do not disconnect the device unless power has been switched off or the area is known to be non-hazardous.

A suitable enclosure must be provided for the end product which has a minimum protection of IP54 and fulfils the requirements of the EN 60079-0.

Reduced output current conditions must be considered for high ambient temperatures and non-standard mounting orientation.

### 3. INPUT VOLTAGE

Input voltage	nom.	DC 24V	
Input voltage range		14.4-32.4Vdc	full specified
	max.	36.0Vdc	absolute maximum continuous input voltage with no damage to the DC/DC converter
Allowed voltage between input and earth	max.	60Vdc or 42.2Vac	in case the output voltage is not grounded.
Allowed input ripple voltage	max.	5Vpp	47Hz-500Hz, the momentary input voltage must always be within the specified limits.
Turn-on voltage	typ.	17.5Vdc	steady-state value, see Fig. 3-1
Shut-down voltage	typ.	14.0Vdc	steady-state value, see Fig. 3-1
	typ.	35.0Vdc	steady-state value, see Fig. 3-1
Input current	typ.	4.25A	at 24Vdc input and output 24V, 3.8A, see Fig. 3-3
Start-up delay	typ.	290ms	see Fig. 3-2
Rise time	typ.	520ms	0mF, 24V, resistive load 3.8A, see Fig. 3-2
	typ.	610ms	3.8mF, 24V, resistive load 3.8A, see Fig. 3-2
Turn-on overshoot	max.	500mV	see Fig. 3-1
Input capacitance	typ.	3 000µF	external capacitors on the input voltage bus are allowed without any limitations.

Fig. 3-1 **Input voltage range**

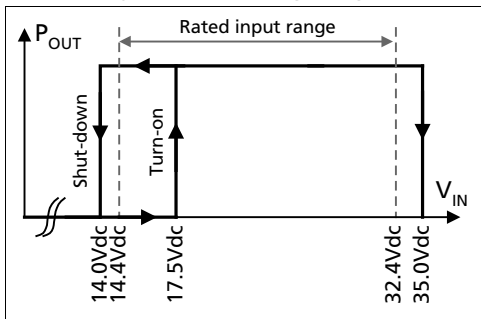

Fig. 3-2 **Turn-on behavior, definitions**

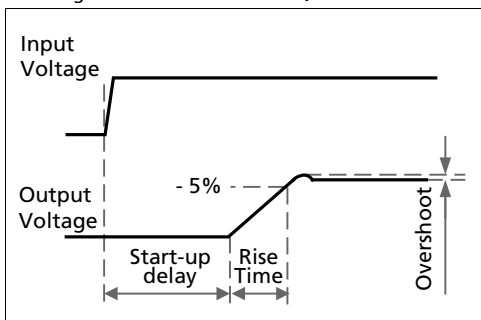
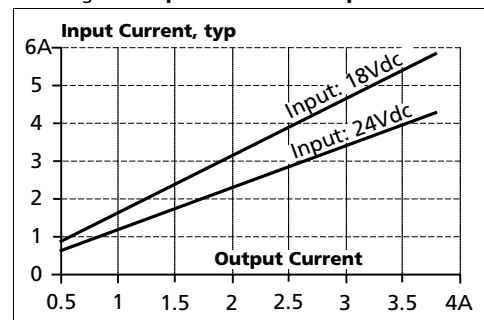

Fig. 3-3 **Input current vs. output load**



### 4. SOFT-START AND INPUT INRUSH CURRENT SURGE

#### Inrush current limitation

An active inrush limitation circuit (inrush limiting resistor which is bypassed by a relay contact) limits the input inrush current after turn-on of the input voltage.

The charging current into EMI suppression capacitors is disregarded in the first microseconds after switch-on.

Inrush current	max.	1.6A <sub>peak</sub>	-25°C to +70°C, input: 24Vdc
	typ.	1.2A <sub>peak</sub>	-25°C to +70°C, input: 24Vdc
Inrush energy	typ.	negligible	-25°C to +70°C, input: 24Vdc

Fig. 4-1 Input inrush current, typical behavior

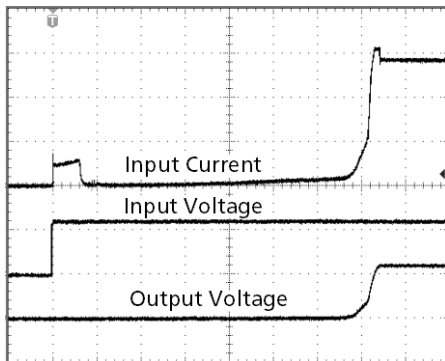

Input: 24Vdc  
 Output: 24V, 3.8A, constant current load  
 Ambient: 25°C

Upper curve: Input current 2A / DIV  
 Middle curve: Input voltage 20V / DIV  
 Lower curve: Output voltage 20V / DIV  
 Time basis: 100ms / DIV

#### Soft-start function:

After the DC/DC converter is turned on, the internal output current rises slowly to its nominal value. This method charges the output capacitors (internal and external capacitors) slowly and avoids high input currents during turn-on. High input currents can produce a high voltage drop on the input wiring (especially with long and thin cables) which reduces the terminal voltage on the DC/DC converter. If the terminal voltage is below the shut-down voltage, the DC/DC converter will turn-off and will make a new start-up attempt. This effect is avoided with the integrated soft-start function. Please note, that this function increases the rise time of the output voltage by a small amount.

Fig. 4-2 Soft-start behavior

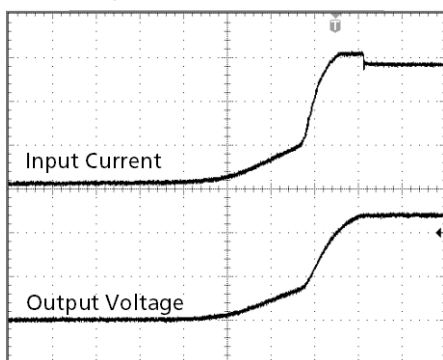

Input: 24Vdc  
 Output: 24V, 3.8A, constant current load  
 Ambient: 25°C  
 No additional external output capacitors

Upper curve: Input current 2A / DIV  
 Lower curve: Output voltage 10V / DIV  
 Time basis: 20ms / DIV

### 5. OUTPUT

Output voltage	nom.	24V	
Adjustment range		-	not adjustable
Factory setting		24.1V	±0.2%, at full load, cold unit
Line regulation	max.	25mV	Input voltage variations between 18 to 32.4Vdc
Load regulation	max.	100mV	static value, 0A → 3.8A
Ripple and noise voltage	max.	50mVpp	20Hz to 20MHz, 50Ohm
Output current	nom.	3.8A	see Fig. 5-1
Output power	nom.	92W	
Short-circuit current	min.	3A	continuous current, short circuit impedance 200mOhm
	max.	6A	continuous current, short circuit impedance 200mOhm
Output capacitance	typ.	2 200µF	

Fig. 5-1 Output voltage vs. output current, typ.

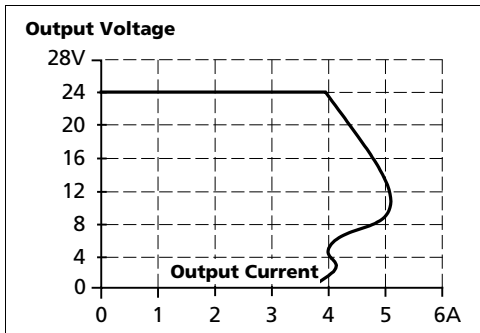
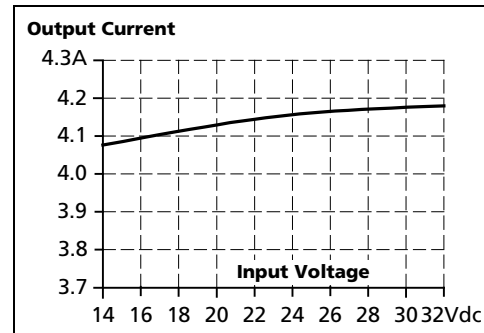

Fig. 5-2 Current limitation vs. input voltage, (23V constant voltage load), typ.



#### Peak current capability (up to several milliseconds)

The DC/DC converter can deliver a peak current, which is higher than the specified short term current. This helps to start current demanding loads or to safely operate subsequent circuit breakers.

The extra current is supplied by the output capacitors inside the DC/DC converter. During this event, the capacitors will be discharged and causes a voltage dip on the output. Detailed curves can be found in chapter 22.1.

Peak current voltage dips	typ.	from 24V to 16V	at 7.6A for 50ms, resistive load
	typ.	from 24V to 12.5V	at 15.2A for 2ms, resistive load
	typ.	from 24V to 8.5V	at 15.2A for 5ms, resistive load

### 6. HOLD-UP TIME

The input side of the DC/DC converter is equipped with a bulk capacitor which keeps the output voltage alive for a certain period of time when the input voltage dips or is removed. The bulk capacitor can be discharged by loading the DC/DC converter on the output side or through a load which is parallel to the input. There is no protection in the DC/DC converter which prevents current from flowing back to the input terminals. If prevention is needed, an external diode should be used.

Hold-up Time	typ.	13.8ms	input 24Vdc, output: 24Vdc, 1.9A, see Fig. 6-1
	typ.	7ms	input 24Vdc, output: 24Vdc, 3.8A, see Fig. 6-1

Fig. 6-1 Hold-up time vs. input voltage

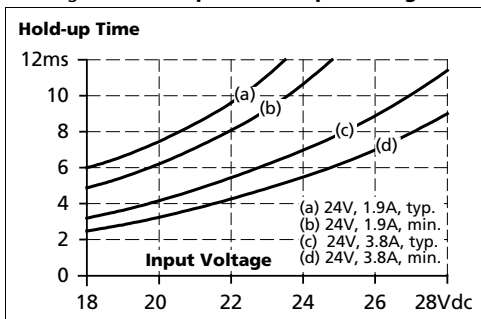

Fig. 6-2 Shut-down test setup

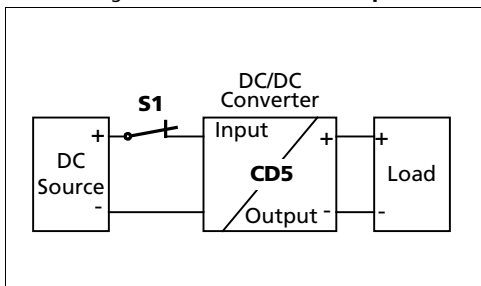
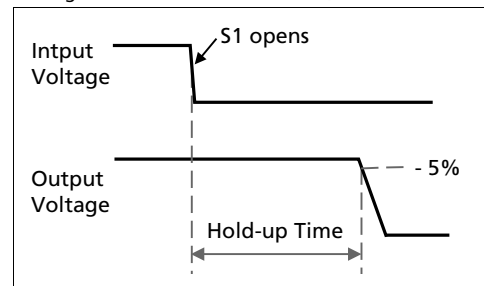

Fig. 6-3 Shut-down behavior, definitions



Note: At no load, the hold-up time can be up to several seconds. The green DC-OK LED is also on during this time.



### 7. EFFICIENCY AND POWER LOSSES

**Input 24Vdc**

Efficiency	typ.	90.5%	at 24V, 3.8A
Power losses	typ.	0.7W	at no output load
	typ.	5.5W	at 24V, 1.9A
	typ.	9.7W	at 24V, 3.8A

Fig. 7-1 Efficiency vs. output current at 24V, typ.

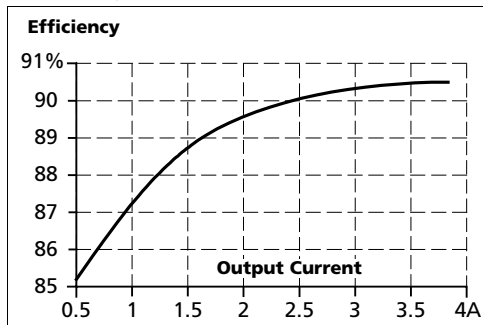

Fig. 7-2 Losses vs. output current at 24V, typ.

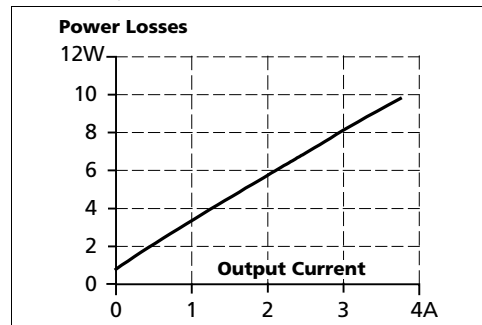

Fig. 7-3 Efficiency vs. input voltage at 24V, 3.8A, typ.

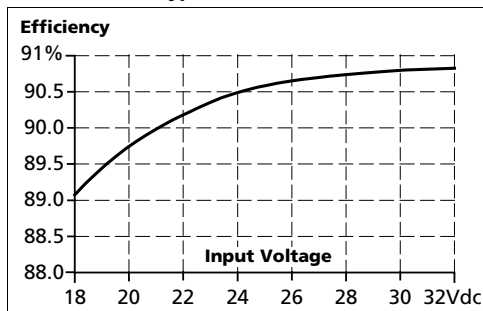
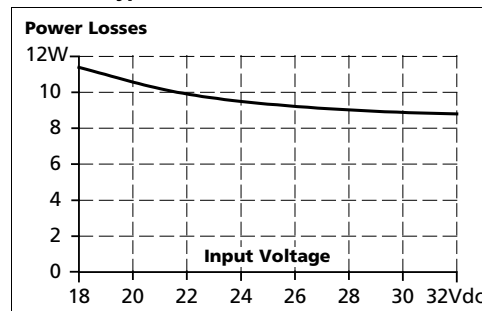
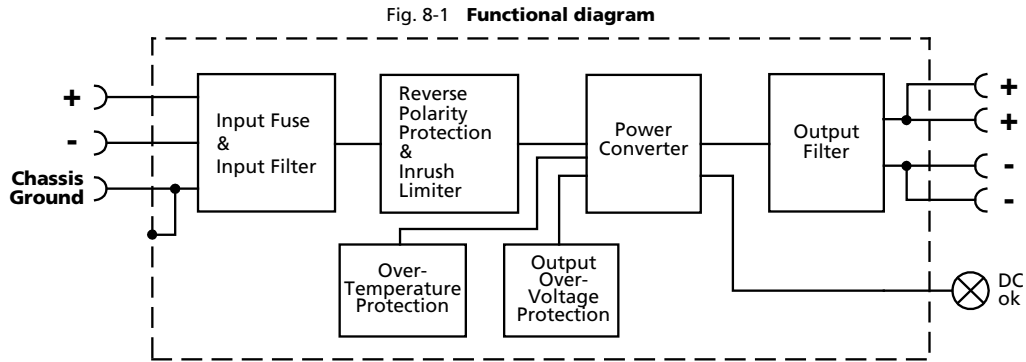

Fig. 7-4 Losses vs. input voltage at 24V, 3.8A, typ.



### 8. FUNCTIONAL DIAGRAM



### 9. FRONT SIDE AND USER ELEMENTS

Fig. 9-1 Front side



- A** Input terminals  
Screw terminals  
+ Positive input  
- Negative (return) input  
Chassis ground: can be used to bond the housing to PE  
Ground this terminal to minimize high-frequency emissions.
- B** Output terminals  
Screw terminals, dual terminals per pole, both pins are equal  
+ Positive output  
- Negative (return) output Screw terminals
- C** DC-OK LED (green)  
On when the voltage on the output terminals is > 21V

### 10. TERMINALS AND WIRING

	<b>Input</b>	<b>Output</b>
Type	spring-clamp terminals	spring-clamp terminals
Solid wire	max. 6mm <sup>2</sup>	max. 6mm <sup>2</sup>
Stranded wire	max. 4mm <sup>2</sup>	max. 4mm <sup>2</sup>
American Wire Gauge	20-10 AWG	20-10 AWG
Wire stripping length	10mm / 0.4inch	10mm / 0.4inch

**Instructions:**

- a) The external circuitry of all terminals must meet the safety requirements stipulated by IEC/EN/UL 60950-1: SELV.
- b) Use appropriate copper cables that are designed for an operating temperature of:
  - 60°C for ambient up to 45°C and
  - 75°C for ambient up to 60°C minimum
  - 90°C for ambient up to 70°C minimum.
- c) Follow national installation codes and installation regulations!
- d) Ensure that all strands of a stranded wire enter the terminal connection!
- e) Screws of unused terminal compartments should be securely tightened.
- f) Screws of unused terminal compartments should be securely tightened.
- g) Ferrules are allowed.
- h) Do not connect or disconnect the wires from the terminals below -25°C (-13°F).

### 11. LIFETIME EXPECTANCY

The Lifetime expectancy shown in the table indicates the minimum operating hours (service life) and is determined by the lifetime expectancy of the built-in electrolytic capacitors. Lifetime expectancy is specified in operational hours and is calculated according to the capacitor's manufacturer specification. The prediction model allows only a calculation of up to 15 years from date of shipment.

	Input 24Vdc	
Lifetime expectancy	173 000h	at 24V, 1.9A and 40°C
	63 000h	at 24V, 3.8A and 40°C
	35 000h	at 24V, 3.8A and 40°C
	179 000h	at 24V, 3.8A and 25°C

### 12. MTBF

**MTBF** stands for **Mean Time Between Failure**, which is calculated according to statistical device failures, and indicates reliability of a device. It is the statistical representation of the likelihood of a unit to fail and does not necessarily represent the life of a product.

The MTBF figure is a statistical representation of the likelihood of a device to fail. A MTBF figure of e.g. 1 000 000h means that statistically one unit will fail every 100 hours if 10 000 units are installed in the field. However, it can not be determined if the failed unit has been running for 50 000h or only for 100h.

	Input 24Vdc	
MTBF SN 29500, IEC 61709	1 161 000h	at 24V, 3.8A and 40°C
	1 904 000h	at 24V, 3.8A and 25°C
MTBF MIL HDBK 217F	610 000h	at 24V, 3.8A and 40°C; Ground Benign GB40
	817 000h	at 24V, 3.8A and 25°C; Ground Benign GB25

### 13. EMC

The DC/DC converter is suitable for applications in industrial environment as well as in residential, commercial and light industry environment without any restrictions.

<b>EMC Immunity</b>	Generic standards: EN 61000-6-1 and EN 61000-6-2			
Electrostatic discharge	EN 61000-4-2	Contact discharge	8kV	Criterion A
		Air discharge	15kV	Criterion A
Electromagnetic RF field	EN 61000-4-3	80MHz-2.7GHz	10V/m	Criterion A
Fast transients (Burst)	EN 61000-4-4	Input lines	4kV	Criterion A
		Output lines	2kV	Criterion A
Surge voltage on input	EN 61000-4-5	+ → -	1kV	Criterion A
		+/- → chassis ground	2kV	Criterion A
Surge voltage on output	EN 61000-4-5	+ → -	500V	Criterion A
		+ / - → chassis ground	1kV	Criterion A
Conducted disturbance	EN 61000-4-6	0.15-80MHz	10V	Criterion A

**Criteria:**

- A:** DC/DC converter shows normal operation behavior within the defined limits.
- C:** Temporary loss of function is possible. DC/DC converter may shut-down and restarts by itself. No damage or hazards for the DC/DC converter will occur.

<b>EMC Emission</b>	Generic standards: EN 61000-6-3 and EN 61000-6-4	
Conducted emission on input	IEC/CISPR 16-1-2, IEC/CISPR 16-2-1	Limits for DC power ports acc. EN 61000-6-3 fulfilled
Radiated emission	EN 55011, EN 55032	Class B

This device complies with FCC Part 15 rules.

Operation is subjected to following two conditions: (1) this device may not cause harmful interference, and (2) this device must accept any interference received, including interference that may cause undesired operation.

**Switching frequency**

Variable between 90kHz and 135kHz depending on load and input voltage (output current > 0.5A)

### 14. ENVIRONMENT

Operational temperature *)	-25°C to +70°C (-13°F to 158°F)	see Fig. 14-1
Storage temperature	-40 to +85°C (-40°F to 185°F)	for storage and transportation
Humidity **)	5 to 95% r.H.	IEC 60068-2-30
Vibration sinusoidal ***)	2-17.8Hz: ±1.6mm; 17.8-500Hz: 2g 2 hours / axis	IEC 60068-2-6
Shock ***)	30g 6ms, 20g 11ms 3 bumps / direction, 18 bumps in total	IEC 60068-2-27
Altitude	0 to 6000m (0 to 20 000ft)	Reduce output power or ambient temperature above 2000m sea level.
Altitude de-rating	5.8W/1000m or 5°C/1000m	above 2000m (6500ft), see Fig. 14-2
Over-voltage category	III II	IEC 62477-1, EN 50178, altitudes up to 2000m Altitudes from 2000m to 6000m
Degree of pollution	2	IEC 62477-1, EN 50178, not conductive

\*) Operational temperature is the same as the ambient temperature and is defined as the air temperature 2cm below the unit.

\*\*) Do not energize while condensation is present

\*\*\*) Tested in combination with DIN rails according to EN 60715 with a height of 15mm and a thickness of 1.3mm and standard mounting orientation.

Fig. 14-1 **Output current vs. ambient temp.**

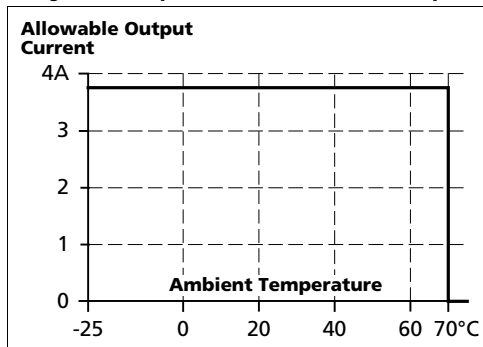
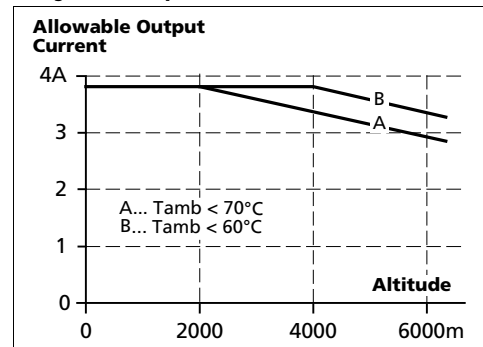

Fig. 14-2 **Output current vs. altitude at 24V**



### 15. PROTECTION FEATURES

Output protection	Electronically protected against overload, no-load and short-circuits *)	
Output over-voltage protection	typ. 31Vdc max. 32Vdc	in case of an internal power supply defect, a redundant circuit limits the maximum output voltage. The output shuts down and automatically attempts to restart.
Reverse input polarity protection	Included	unit does not start when input voltage is reversed
Output over-current protection	electronically limited *)	see Fig. 5-1
Degree of protection	IP 20	EN/IEC 60529
Penetration protection	> 3.5mm	e.g. screws, small parts
Over-temperature protection	yes	output shut-down with automatic restart
Input transient protection	MOV	Metal Oxide Varistor
Internal input fuse	included	not user replaceable

\*) In case of a protection event, audible noise may occur.

### 16. SAFETY FEATURES

Classification of output voltage	SELV PELV	IEC/EN 60950-1 IEC/EN 60204-1, EN 50178, IEC 62477-1, IEC 60364-4-41
Class of protection	III	PE (Protective Earth) connection not required. A connection of the "Chassis Ground" pin to earth is recommended for best EMI performance
Isolation resistance	> 5MΩ	input to output, 500Vdc
PE resistance	< 0.1Ω	between housing and Chassis Ground terminal
Touch current (leakage current)	The leakage current which is produced by the DC/DC converter itself depends on the input voltage ripple and need to be investigated in the final application. For a smooth DC input voltage, the produced leakage current is less than 100µA.	

\*) provided, that the input voltage meets the requirements of chapter 2.

### 17. DIELECTRIC STRENGTH

The output voltage is floating and has no ohmic connection to the ground.

Type and factory tests are conducted by the manufacturer. Field tests may be conducted in the field using the appropriate test equipment which applies the voltage with a slow ramp (2s up and 2s down). Connect all input terminals together as well as all output poles before conducting the test. When testing, set the cut-off current settings to the value in the table below.

Fig. 17-1 Dielectric strength

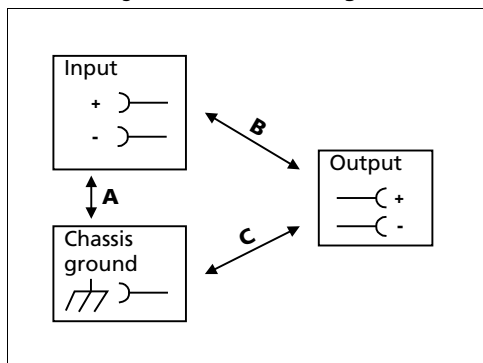







		<b>A</b>	<b>B</b>	<b>C</b>
Type test	60s	1500Vac	1500Vac	500Vac
Factory test	5s	1500Vac	1500Vac	500Vac
Field test	5s	1000Vac	1000Vac	500Vac
Cut-off current setting		> 30mA	> 30mA	> 12mA

To fulfill the PELV requirements according to EN60204-1 § 6.4.1, we recommend that either the + pole, the - pole or any other part of the output circuit shall be connected to the protective earth system. This helps to avoid situations in which a load starts unexpectedly or can not be switched off when unnoticed earth faults occur.



### 18. APPROVED, FULFILLED OR TESTED STANDARDS

UL 508		UL Certificate Listed equipment for category NMTR - Industrial Control Equipment Applicable for US and Canada E-File: E198865
IEC 61010-1	<b>CB Report</b>	CB Scheme Certificate Safety requirements for electrical equipment for measurement, control and laboratory use - General requirements
UL 61010-1		UL Certificate Recognized component for category QQHC - Safety Requirements for Electrical Equipment for Measurement, Control, and Laboratory Use - General Requirements Applicable for US and Canada E-File: E326782
IEC 60950-1	<b>CB Report</b>	CB Scheme Certificate General safety requirements for Information Technology Equipment (ITE)
UL 60950-1		UL Certificate Recognized component for category QQQ - Information Technology Equipment (ITE) Applicable for US and Canada E-File: E137006
ATEX		Agency Certificate (Bureau Veritas) EN 60079-0 Explosive atmospheres - General requirements EN 60079-7, EN 60079-15 Equipment protection by type of protection "e" and "n" Certificate: EPS 08 ATEX 1 142 X Temperature Code: T4 Type of Protection: ec nC
IECEX	<b>IECEX</b>	IECEX Certificate IEC 60079-0 Explosive atmospheres - General requirements IEC 60079-7, IEC 60079-15 Equipment protection by type of protection "e" and "n" Certificate: IECEX EPS 14.0001X Temperature Code: T4 Type of Protection: ec nC
Class I Div 2		CSA Certificate Power Supplies for Hazardous Location Applicable for Canada and US CSA Class: 5318-01 (Canada), 5318-81 (USA) Temperature Code: T4 Groups: A, B, C and D
Class I Div 2		UL Certificate Listed equipment for category NRAD - Listed equipment Industrial Control Equipment for Use in Hazardous Locations Applicable for US and Canada E-File: E327416 Temperature Code: T4 Groups: A, B, C and D

Marine (DNV)



DNV Certificate  
 DNV Type approved product  
 Certificate: TAA00002YX  
 Temperature: Class D  
 Humidity: Class B  
 Vibration: Class C  
 EMC: Class B  
 Enclosure: Class A

Marine (ABS)



ABS Design Assessment Certificate  
 ABS (American Bureau of Shipment) assessed product  
 Certificate: 17-HG1599236-PD

NEC CLASS 2



Manufacturer's Declaration  
 NEC Class 2 - Limited Power Source  
 Listed device according to NEC Handbook chapter 725-121

IEC 60068-2-60

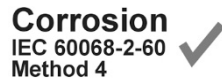

Manufacturer's Declaration (Online Document)  
 Environmental Tests, Flowing Mixed Gas Corrosion Test  
 Test Ke - Method 4  
 H2S: 10ppb  
 NO2: 200ppb  
 Cl2: 10ppb  
 SO2: 200ppb  
 Test Duration: 3 weeks, which simulates a service life of 10 years.

ISA-71.04-1985



Manufacturer's Declaration (Online Document)  
 Airborne Contaminants Corrosion Test  
 Severity Level: G3 Harsh  
 H2S: 100ppb  
 NOx: 1250ppb  
 Cl2: 20ppb  
 SO2: 300ppb  
 Test Duration: 3 weeks, which simulates a service life of 10 years.

VDMA 24364



Paint Wetting Impairment Substances Test (or LABS-Test)  
 Tested for Zone 2 and test class C1 according to VDMA 24364-C1-L/W for solvents and water-based paints

## 19. REGULATORY PRODUCT COMPLIANCE

EU Declaration of Conformity



The CE mark indicates conformance with the  
 - EMC directive  
 - ATEX directive  
 - RoHS directive

REACH Directive



Manufacturer's Statement  
 EU-Directive regarding the Registration, Evaluation, Authorization and Restriction of Chemicals

WEEE Directive



Manufacturer's Statement  
 EU-Regulation on Waste Electrical and Electronic Equipment Registered in Germany as business to business (B2B) products.

EAC TR Registration



EAC Certificate  
 EAC EurAsian Conformity - Registration Russia, Kazakhstan and Belarus  
 8504408200, 8504409000

### 20. PHYSICAL DIMENSIONS AND WEIGHT

Weight	425g / 0.94lb
DIN rail	Use 35mm DIN rails according to EN 60715 or EN 50022 with a height of 7.5 or 15mm. The DIN rail depth must be added to the unit depth (102mm) to calculate the total required installation depth.
Installation Clearances	See chapter 2

Fig. 20-1 **Front view**

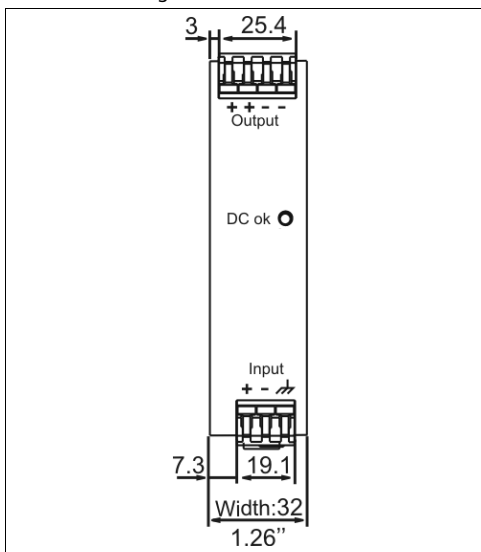
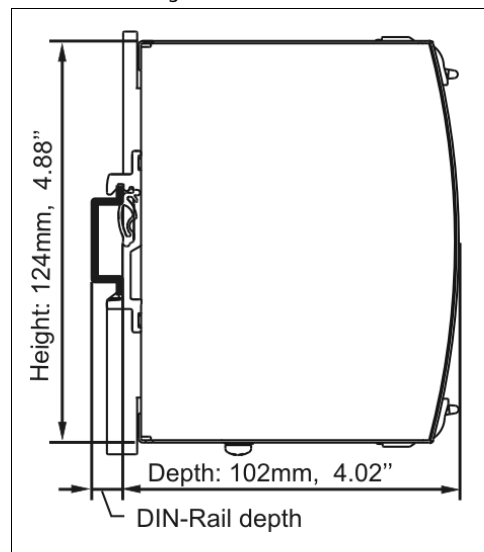

Fig. 20-2 **Side view**



## 21. ACCESSORIES

### 21.1. ZM1.WALL - WALL MOUNTING BRACKET

This bracket is used to mount specific Dimension units onto a flat surface without utilizing a DIN rail. The two aluminum brackets and the black plastic slider of the unit have to be removed, so that the two steel brackets can be mounted.

Fig. 21-1 ZM1.Wall Wall mounting bracket\*)

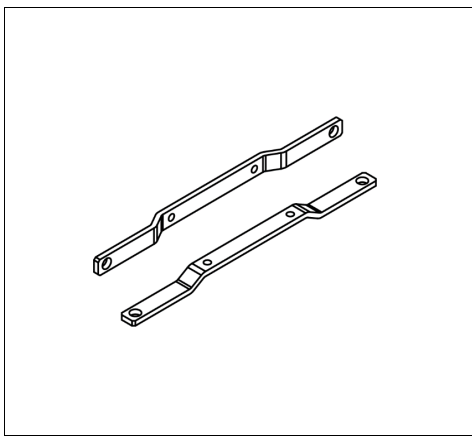

\*) PSU for illustration purpose only.

Fig. 21-2 Wall mounting with DIN rail brackets\*)

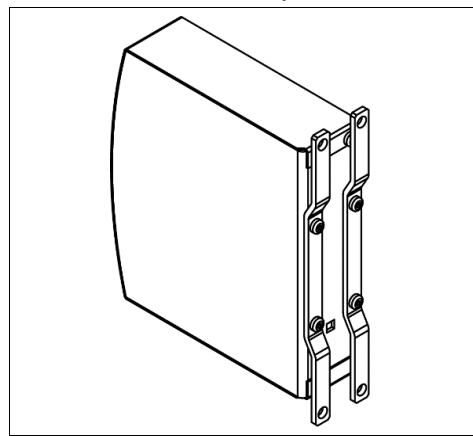

### 21.2. ZM10.WALL - WALL/PANEL MOUNT BRACKET

This bracket is used to mount the devices on a wall/panel without utilizing the DIN rail. The bracket can be mounted without detaching the DIN rail brackets from the power supply.

Fig. 21-3 ZM10.Wall Wall mounting bracket\*)

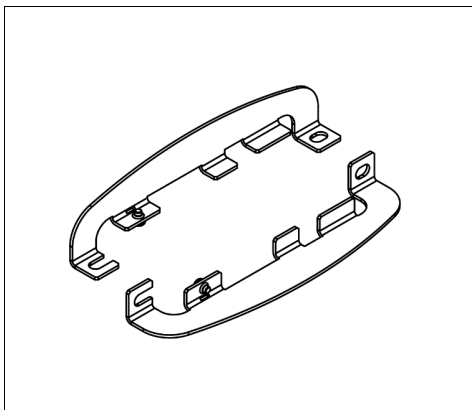

\*) PSU for illustration purpose only.

Fig. 21-4 Wall mounting with DIN rail brackets\*)

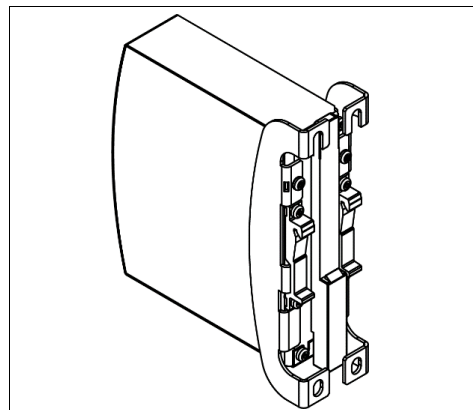

### 21.3. ZM11.SIDE - SIDE MOUNTING BRACKET

This bracket is used to mount Dimension units sideways with or without utilizing a DIN rail. The two aluminum brackets and the black plastic slider of the unit have to be detached, so that the steel brackets can be mounted.

For sideways DIN rail mounting, the removed aluminum brackets and the black plastic slider need to be mounted on the steel bracket.

Fig. 21-5 ZM11.SIDE Side mounting bracket \*)

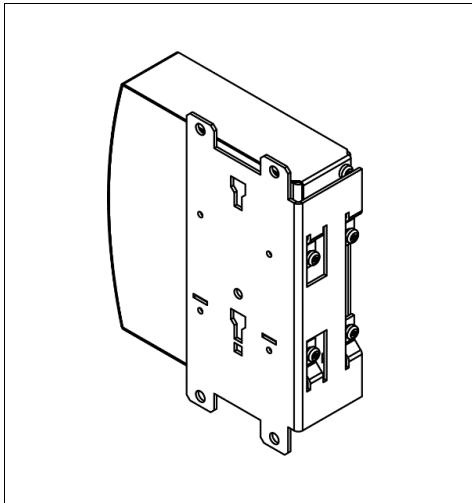
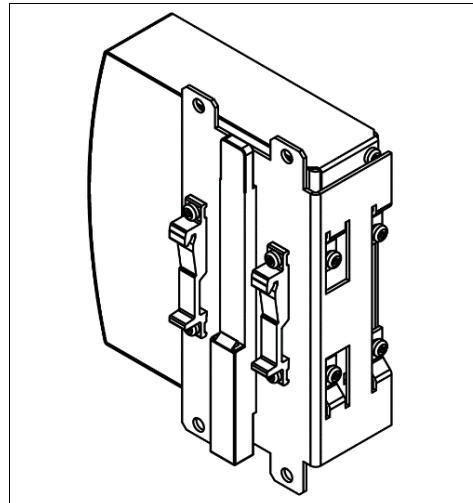

Fig. 21-6 Side mounting with DIN rail brackets \*)



\*) PSU for illustration purpose only.

### 21.4. YRM2.DIODE REDUNDANCY MODULE



The YRM2.DIODE is a dual redundancy module, which can be used to build 1+1 and N+1 redundant systems. It is equipped with two input channels, which are individually decoupled by utilizing diodes.

The YRM2.DIODE does not require an additional auxiliary voltage and is self-powered even in case of a short circuit across the output.

The YRM2.DIODE has a monitoring circuit included and is the perfect solution when the power supply has no DC-OK function. Two LEDs and two relay contacts signal when one of the two DC-input voltages is not in range due to a non-functioning or disconnected power supply.

Due to the compact design, the unit is very slender and only requires 32mm width on the DIN rail.

## 22. APPLICATION NOTES

### 22.1. PEAK CURRENT CAPABILITY

Solenoids, contactors and pneumatic modules often have a steady state coil and a pick-up coil. The inrush current demand of the pick-up coil is several times higher than the steady-state current and usually exceeds the nominal output current (including the PowerBoost). The same situation applies, when starting a capacitive load.

Branch circuits are often protected with circuit breakers or fuses. In case of a short or an overload in the branch circuit, the fuse needs a certain amount of over-current to trip or to blow. The peak current capability ensures the safe operation of subsequent circuit breakers.

Assuming the input voltage is turned on before such an event, the built-in large sized output capacitors inside the DC/DC converter can deliver extra current. Discharging this capacitor causes a voltage dip on the output. The following two examples show typical voltage dips:

Fig. 22-1 Peak loading with 2x the nominal current for 50ms, typ.

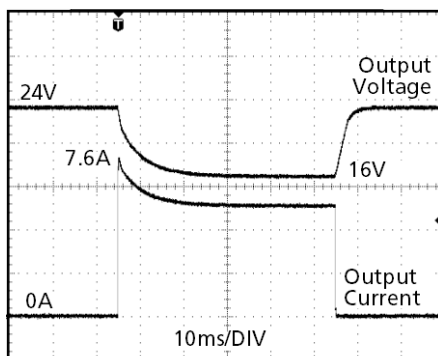

Peak load 7.6A (resistive load) for 50ms  
Output voltage dips from 24V to 16V.

Fig. 22-2 Peak loading with 5x the nominal current for 5ms, typ.

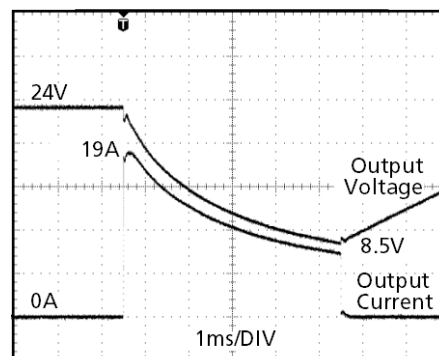

Peak load 19A (resistive load) for 5ms  
Output voltage dips from 24V to 8.5V.

### 22.2. BACK-FEEDING LOADS

Loads such as decelerating motors and inductors can feed voltage back to the DC/DC converter. This feature is also called return voltage immunity or resistance against Back- E.M.F. (E)lectro (M)agnetic Force).

This DC/DC converter is resistant and does not show malfunctioning when a load feeds back voltage to the DC/DC converter. It does not matter, whether the DC/DC converter is on or off.

The maximum allowed feed-back-voltage is 30Vdc. The absorbing energy can be calculated according to the built-in large sized output capacitance which is specified in chapter 5.

### 22.3. INDUCTIVE AND CAPACITIVE LOADS

The unit is designed to supply any kind of loads, including unlimited capacitive and inductive loads.

### 22.4. EXTERNAL INPUT PROTECTION

The unit is tested and approved for branch circuits up to 50A. An external protection is only required, if the supplying branch has an ampacity greater than this. Check also local codes and local requirements. In some countries local regulations might apply.

If an external fuse is necessary or utilized, minimum requirements need to be considered to avoid nuisance tripping of the circuit breaker. A minimum value of 10A B- or 8A C-Characteristic breaker should be used.

### 22.5. REQUIREMENTS FOR THE SUPPLYING SOURCE

In certain circumstances, the input filter of the DC/DC converter can show a resonant effect which is caused by the supplying network. Especially when additional external input filters are utilized, a superimposed AC voltage can be generated on the input terminals of the DC/DC converter which might cause a malfunction of the unit. Therefore, additional input filters are not recommended. To avoid the resonant effects, the minimal resistance of the supplying network which depends on the inductance of the input network, shall be above the boundary curve in Fig. 22-3.

Fig. 22-3 External input filter requirements to avoid filter instabilities

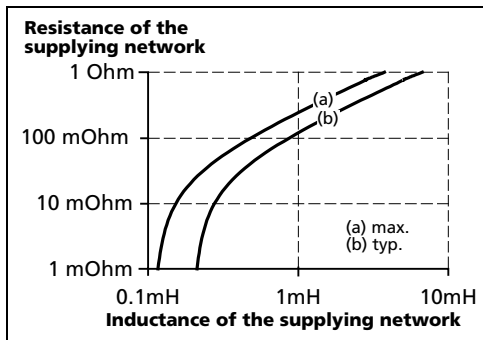

### 22.6. PARALLEL USE TO INCREASE OUTPUT POWER

This DC/DC-converter is designed to meet the NEC Class 2 requirements. Do not use in parallel to increase the output current. This would increase the output current and violates the NEC Class 2 limitations. Use CD5.241 or CD5.241-S1.

### 22.7. PARALLEL USE FOR REDUNDANCY

This DC/DC-converter is designed to meet the NEC Class 2 requirements. Do not use in parallel for redundancy. This would increase the output current and violates the NEC Class 2 limitations. Use CD5.241 or CD5.241-S1.

## 22.8. SERIES OPERATION

This DC/DC-converter is designed to meet the NEC Class 2 requirements. Do not use in series to increase the output voltage. This would increase the output power for the NEC Class 2 circuit and violates the NEC Class 2 limitations. Use CD5.241 or CD5.241-S1.

## 22.9. CHARGING OF BATTERIES

This DC/DC converter can not be used to charge batteries. The output voltage is not adjustable.

## 22.10. USE IN A TIGHTLY SEALED ENCLOSURE

When the DC/DC converter is installed in a tightly sealed enclosure, the temperature inside the enclosure will be higher than outside. In such situations, the inside temperature defines the ambient temperature for the DC/DC converter.

The following measurement results can be used as a reference to estimate the temperature rise inside the enclosure.

The DC/DC converter is placed in the middle of the box, no other heat producing items are inside the box

Enclosure:	Rittal Typ IP66 Box PK 9516 100, plastic, 110x180x165mm
Load:	24V, 3A; (=80%) load is placed outside the box
Input:	24Vdc
Temperature inside enclosure:	37.7°C (in the middle of the right side of the DC/DC converter with a distance of 2cm)
Temperature outside enclosure:	22.2°C
Temperature rise:	15.5K



### 22.11. MOUNTING ORIENTATIONS

Mounting orientations other than input terminals on the bottom and output on the top require a reduction in continuous output power or a limitation in the max. allowed ambient temperature. The amount of reduction influences the lifetime expectancy of the DC/DC converter. Therefore, two different derating curves for continuous operation can be found below:

**Curve A1** Recommended output current.

**Curve A2** Max allowed output current (results in approximately half the lifetime expectancy of A1).

Fig. 22-4  
**Mounting Orientation A**  
(Standard orientation)

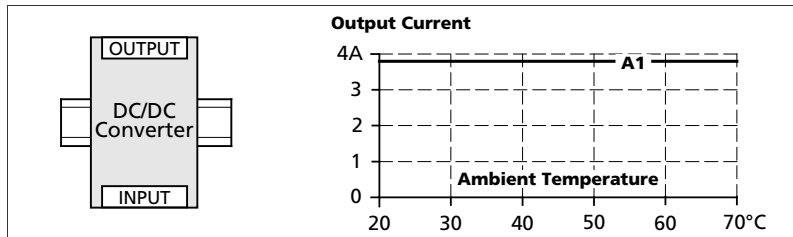

Fig. 22-5  
**Mounting Orientation B**  
(Upside down)

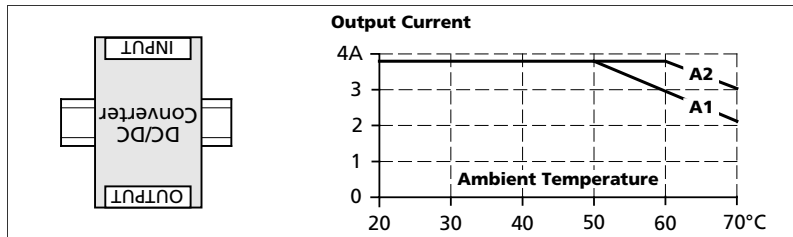

Fig. 22-6  
**Mounting Orientation C**  
(Table-top mounting)

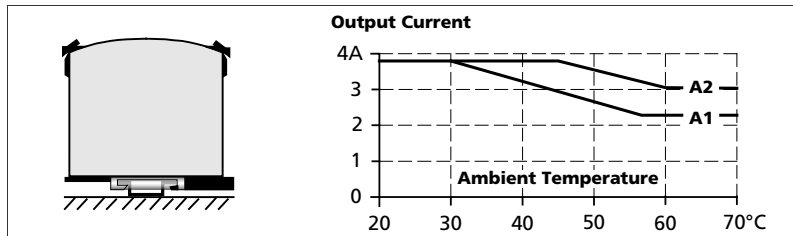

Fig. 22-7  
**Mounting Orientation D**  
(Horizontal cw)

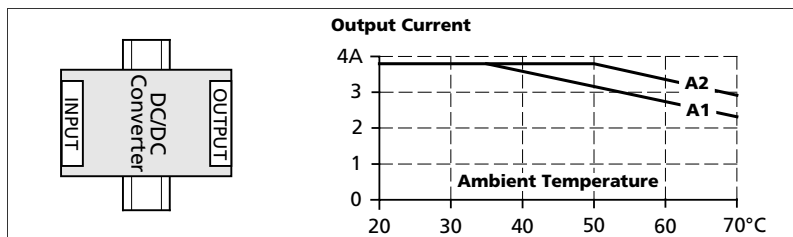

Fig. 22-8  
**Mounting Orientation E**  
(Horizontal ccw)

