

**NOVOHALL
Rotary Sensor
Touchless**

**RFD-4000
Ratiometric**

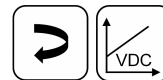

Special Features

- Fully touchless - no shaft or seals to wear
- Measure directly through any non-ferromagnetic material
- Electrical range up to 360°
- Linearity $\pm 0.5\%$
- Simple mounting
- Lateral magnet offset up to ± 3 mm
- Protection class IP67, IP68, IP69
- One and multi-channel versions
- Unlimited mechanical lifetime
- High resolution to 12 bit
- Excellent price/performance ratio
- Extremely flat 7 mm design

Applications

- Manufacturing Engineering (textile machinery, packaging machinery, sheet metal and wire machinery)
- Medical Engineering
- Mobile working machines (industrial trucks, construction machinery, agricultural and forestry machinery)
- Marine applications

The RFD-4000 utilizes a separate magnet or magnetic position marker, attached to the rotating shaft to be measured. The orientation of the magnetic field is measured and an analog voltage representing the angle is the output signal. The very compact physical dimensions allows installation in small spaces. The housing is made of high grade temperature-resistant plastic material. The sensor is sealed and is not sensitive to dust, dirt, or moisture. The two-part design, with the RFD sensor itself, and its magnetic position marker, offers great flexibility when mounting. The absence of shaft and bearing makes the assembly much less sensitive to axial and radial application tolerances. Measurements can be made transmissively through any nonferromagnetic material. Electrical connection is made via lead wires.

Description

Material	Housing: high grade, temperature resistant plastic PBT GF with brass inserts
Mounting	With 2 pan head screws M4x14 (included in delivery)
Fastening torque of mounting	max. 150 Ncm
Electrical connection	Lead wires 0.5 mm ² (AWG 20), PVC

Mechanical Data

Dimensions	See dimension drawing
Mechanical travel	continuous
Weight	approx. 10 g

Ordering Specifications

Ordering Specifications Preferred types printed in bold <ul style="list-style-type: none"> • Delivery time up to 25 pcs. within 10 working days EXW • Best low-volume pricing 		Supply voltage Ub 2: Ub = 5 VDC	
		Output signal 1: 5 ... 95% ratiometric to supply voltage Ub (0.25 ... 4.75 VDC) 2: 10 ... 90% ratiometric to supply voltage Ub (0.5 ... 4.5 VDC)	
		Output characteristic 1: Rising characteristic cw 2: Rising characteristic ccw 3: Crossed outputs, channel 1 rising cw (partly redundant) 4: Crossed outputs, channel 1 rising cw (fully redundant) Other output characteristics on request	
		Electrical connection 401: Lead wires, 3x L = 0.5 m (single) 411: Lead wires, 4x L = 0.5 m (partly redundant) 421: Lead wires, 6x L = 0.5 m (fully redundant) Cable versions and assembled connectors on request	
R F D - 4 0 2 1 - 6 3 6 - 2 1 1 - 4 0 1			
Series	Mechanical version 4021: Standard design	Measuring range 03: Angle 0° ... 30° min. ... 06, 12, 18, 24, 36 ... 36: Angle 0° ... 360° max. Other angles on request	Number of channels 6: One-channel version (1x supply voltage Ub, 1x output) 7: Partly redundant version (1x supply voltage Ub, 2x output) 8: Fully redundant version (2x supply voltage Ub, 2x output)

Accessories included in delivery

- 2x Pan head screws M4x14

Drawing

CAD data see
www.novotechnik.de/en/download/cad-data/

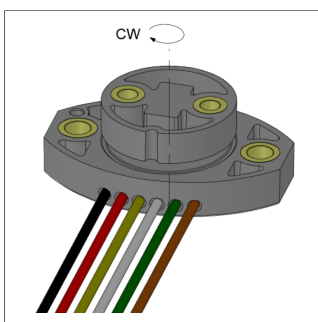
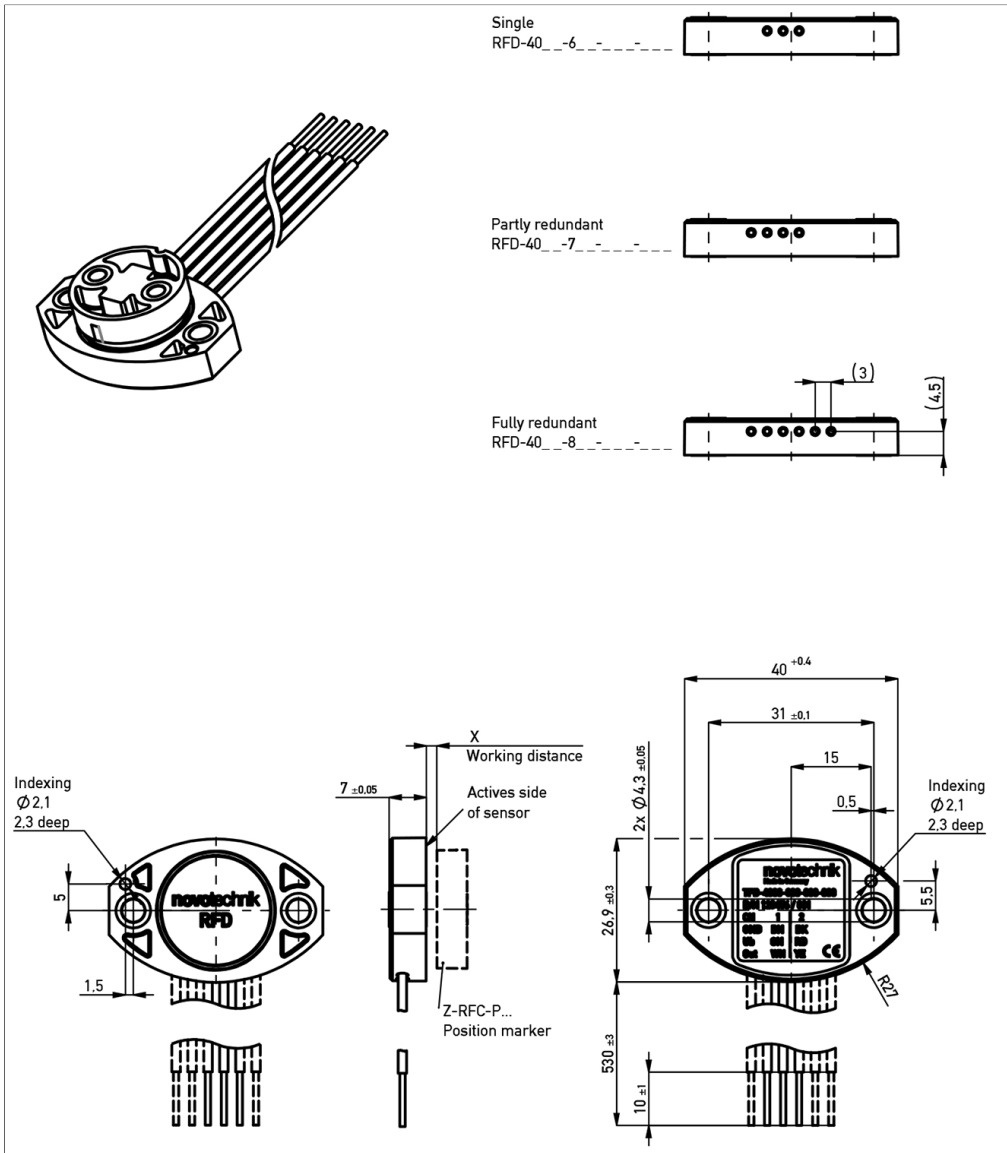

When the marking of the position marker is pointing towards the electrical outlet, the sensor output is near the electrical center position.

Technical Data

Type	RFD-40 _ _ _ _ -2_ _ _ _ Ratiometric
Output signal	ratiometric to supply voltage U_b 5 ... 95% (0.25 ... 4.75 V) 10 ... 90% (0.5 ... 4.5 V)
Load	$\geq 10 \text{ k}\Omega$
Number of channels	1 / 2
Diagnosis	activated (in case of error, output signal is outside of the plausible signal range)
Update rate	typ. 2.5 kHz
Measuring range	0 ... 30° up to 0 ... 360° in 10°-steps
Independent linearity	$\leq \pm 0.5 \text{ \%FS}$ (at pull-down resistor 10 k Ω)
Resolution	12 bits
Repeatability	typ. $\leq \pm 0.1^\circ$
Temperature error	Measuring range 30 ... 170°: typ. $\pm 0.875 \text{ \%FS}$, Measuring range $\geq 180^\circ$: typ. $\pm 0.6 \text{ \%FS}$
Supply voltage U_b	5 VDC (4.5 ... 5.5 VDC)
Current consumption w/o load	typ. 13 mA per channel (typ. 8 mA on request)
Polarity protection	yes (supply lines)
Short circuit protection	yes (all outputs vs. GND and supply voltage)
Insulation resistance (500 VDC)	$\geq 10 \text{ M}\Omega$
Environmental Data	
Max. operational speed	Mechanically unlimited
Vibration IEC 60068-2-6	20 g, 5 ... 2000 Hz, $A_{max} = 0.75 \text{ mm}$
Shock IEC 60068-2-27	50 g, 6 ms
Protection class DIN EN 60529	IP67 / IP68 / IP69
Operating temperature	-40 ... +125°C
Life	Mechanically unlimited
Functional safety	If you need assistance in using our products in safety-related systems, please contact us
MTTF (IEC 60050)	9926 years (one-channel), 4441 years (partly redundant, per channel) or 4512 years (fully redundant, per channel)
Traceability	Serial number on type labeling: production batch of the sensor assembly and relevant sensor components
Conformity/Approval	CE, UKCA see https://www.novotechnik.de/en/downloads/certificates/declarations-of-conformity-eu/uk WEEE see https://www.novotechnik.de/en/downloads/certificates/eu-directive-weee/
EMC Compatibility	
ISO 10605 ESD (Handling/Component)	8 kV / 15 kV
ISO 11452-2 Radiated HF-fields	200 V/m
ISO 11452-5 Radiated HF-Fields, stripline	200 V/m
CISPR 25 Radiated emission	Level 5
EN 61000-4-4 Fast transients (burst)	1 kV
EN 61000-4-6 Cond. disturbances (HF fields)	10 V eff.
EN 61000-4-8 Magnetic fields	30 A/m

FS = Full scale: Signal span according to electrical measuring range

Available on request: SPI or PWM interface

Connection Assignment

Signal	Lead wires code 40_	Lead wires code 41_	Lead wires code 42_
	One-channel	Partly redundant	Fully redundant
Supply voltage U_b 1	GN	GN	GN
GND 1	BN	BN	BN
Signal output 1	WH	WH	WH
Signal output 2	-	YE	YE
Supply voltage U_b 2	-	-	RD
GND 2	-	-	BK

**Technical Data
Output
Characteristics**

Output characteristic

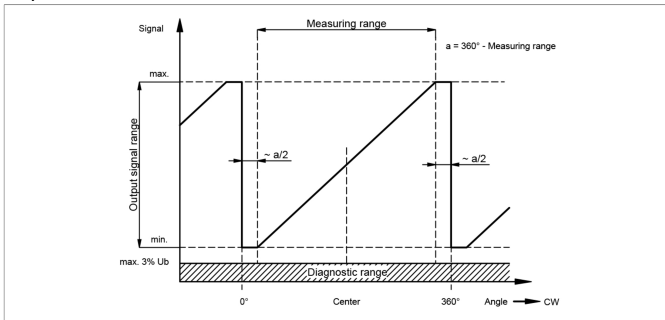

Output characteristic

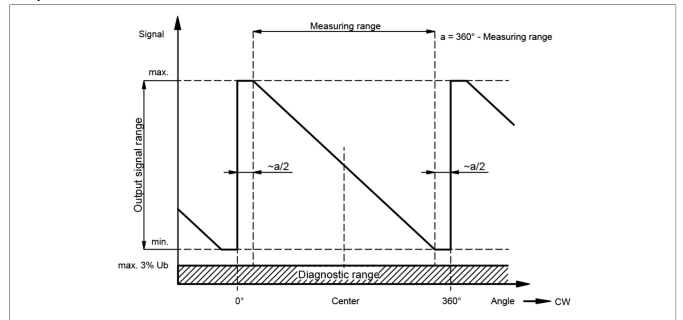

Output characteristic

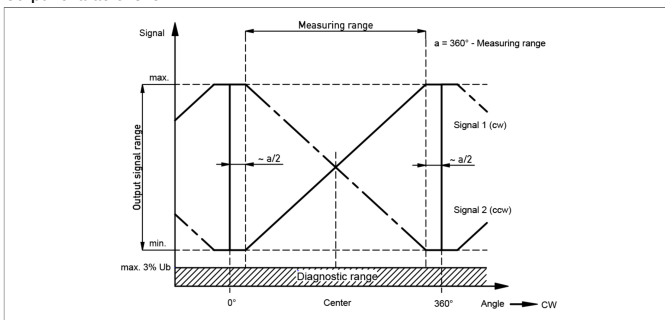

Output characteristic

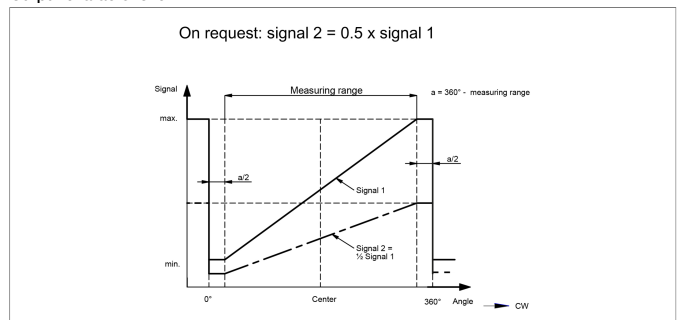

Output characteristic

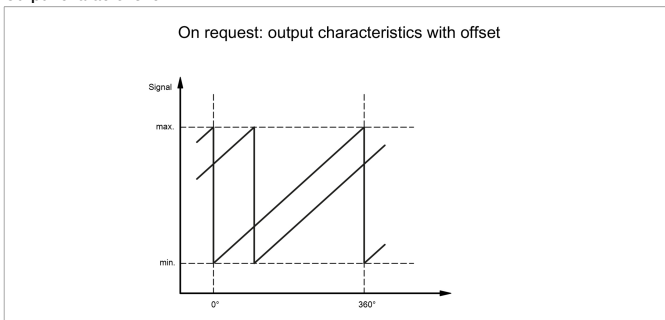

Output characteristic

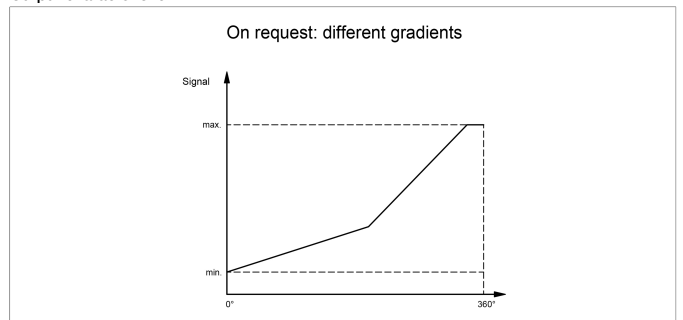

Output characteristic

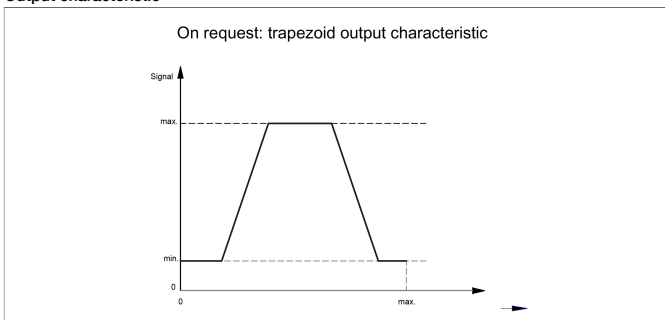

Output characteristic

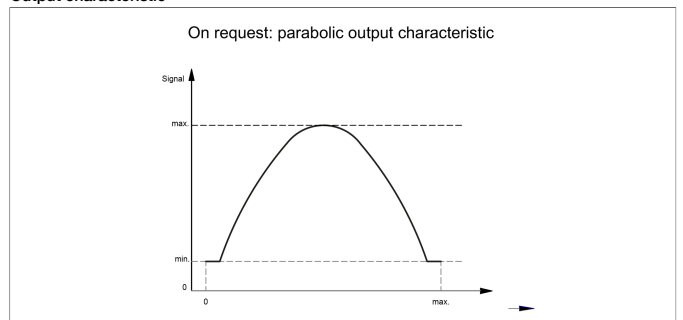

Position Markers

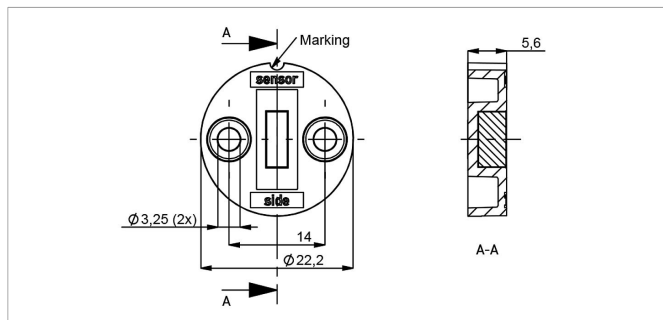

Z-RFC-P30

Position marker for frontal fixation with 2 cylinder screws M3x8 (included in delivery).

Material PBT-GF

Max. permitted ± 1.5 mm

radial offset

Operating temp. $-40 \dots +125^\circ\text{C}$

P/N	Pack. unit [pcs]
400056086	1
400056087	25

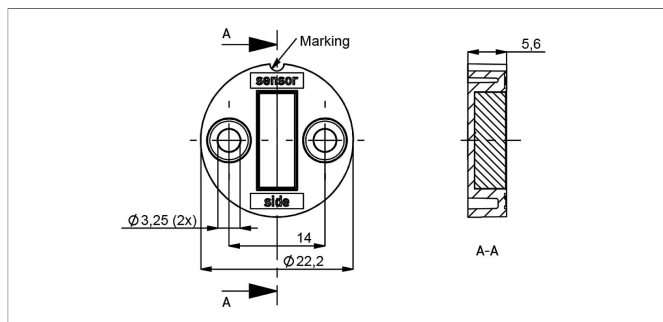

Z-RFC-P31

Position marker for frontal fixation with 2 cylinder screws M3x8 (included in delivery).

Material PBT-GF

Max. permitted ± 3 mm

radial offset

Operating temp. $-40 \dots +125^\circ\text{C}$

P/N	Pack. unit [pcs]
400056088	1
400056089	25

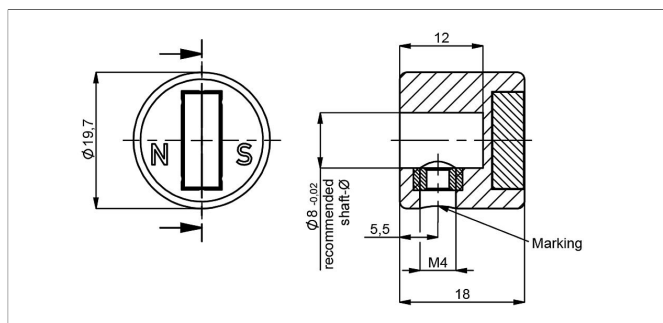

Z-RFC-P23

Position marker for fixation with threaded pin M4 (included in delivery)

Caution: For orientation of the output characteristic please follow the user manual of the position marker!

Material PA6-GF

Max. permitted ± 3 mm

radial offset

Operating temp. $-40 \dots +125^\circ\text{C}$

P/N	Pack. unit [pcs]
400056074	1
400056085	25

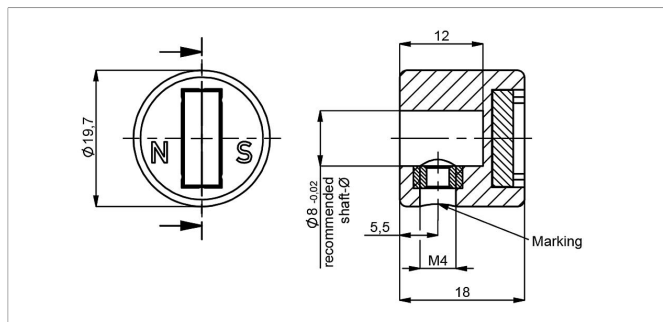

Z-RFC-P43

Position marker for fixation with threaded pin M4 (included in delivery)

Caution: For orientation of the output characteristic please follow the user manual of the position marker!

Material PA6-GF

Max. permitted ± 3 mm

radial offset

Operating temp. $-40 \dots +125^\circ\text{C}$

P/N	Pack. unit [pcs]
400105041	1
400105042	25

Position Markers

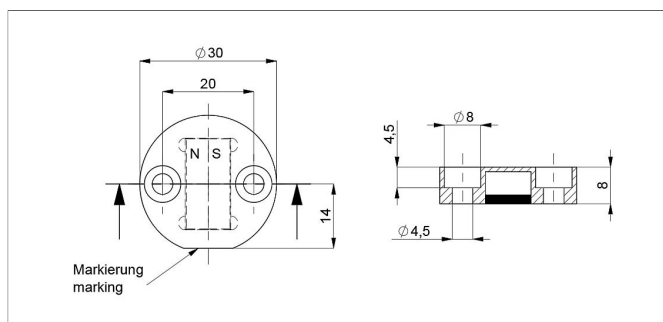

Z-RFC-P22

Position marker for frontal fixation with 2 cylinder head screws M4x20 (with screw lock, included in delivery).

Attention: Closed side of position marker faces the active side of sensor.

Material Aluminium, anodized
Max. permitted radial offset ± 4 mm
Operating temp. $-40 \dots +125^\circ\text{C}$

P/N	Pack. unit [pcs]
400106735	1
400106736	25

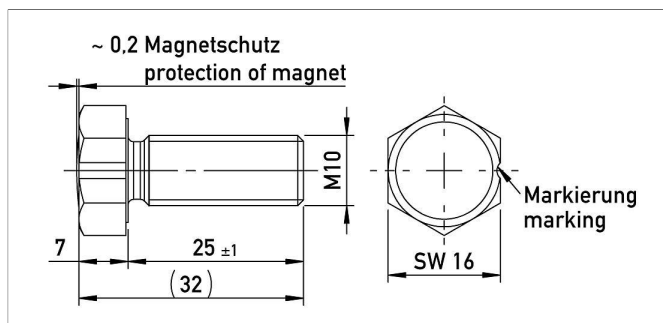

Z-RFC-P18

Screw position marker M10 x 25 mm, similar DIN 933, magnet potted

Material Aluminium, anodized
Max. permitted radial offset ± 3 mm
Operating temp. $-40 \dots +125^\circ\text{C}$

P/N	Pack. unit [pcs]
400104756	1
400104757	25

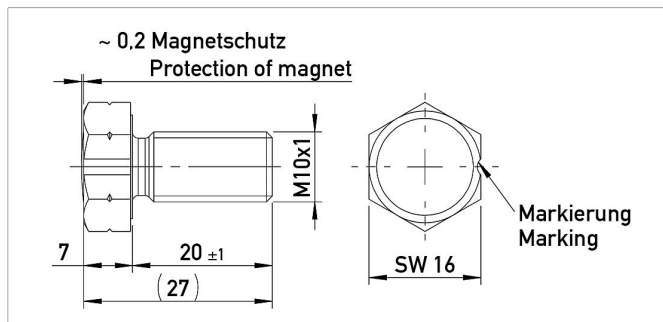

Z-RFC-P28

Screw position marker M10x1 x 20 mm, similar DIN 933, magnet potted

Material Aluminium, anodized
Max. permitted radial offset ± 3 mm
Operating temp. $-40 \dots +125^\circ\text{C}$

P/N	Pack. unit [pcs]
400108462	1
400108463	25

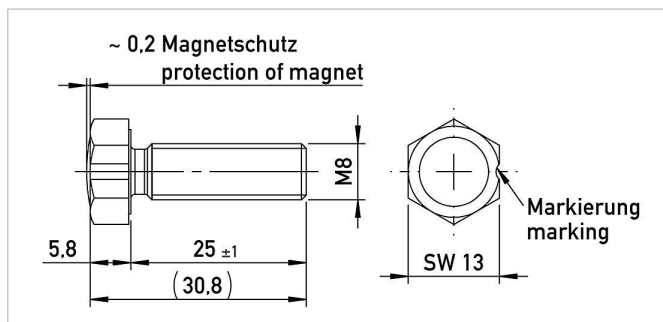

Z-RFC-P19

Screw position marker M8 x 25 mm, similar DIN 933/ISO 4017, magnet potted

Material Aluminium, anodized
Max. permitted radial offset ± 1.5 mm
Operating temp. $-40 \dots +125^\circ\text{C}$

P/N	Pack. unit [pcs]
400104754	1
400104755	25

Position Markers

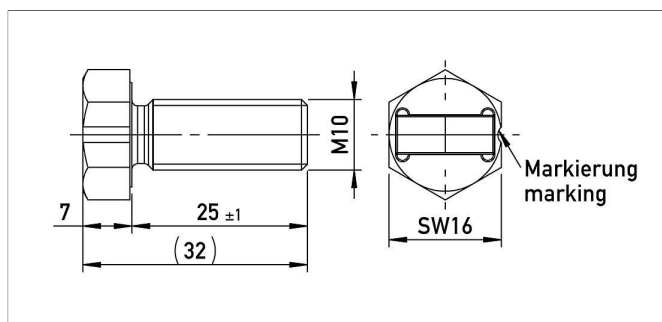

Z-RFC-P20

Screw position marker M10 x 25 mm, similar
DIN 933

Material Aluminium, anodized

Max. permitted radial offset ± 3 mm

radial offset

Operating temp. -40 ... +125°C

P/N	Pack. unit [pcs]
400104758	1
400104759	25

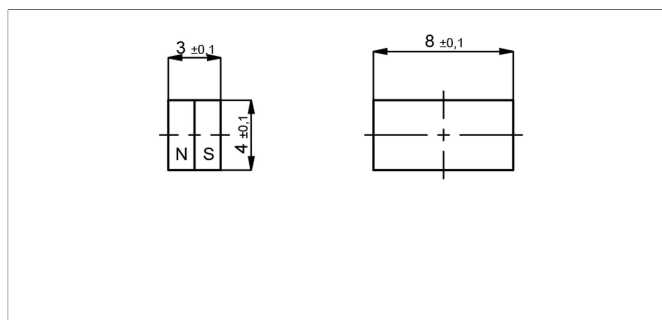

Z-RFC-P03

Magnet for direct application onto customer's shaft (see user manual).

We recommend mounting on non-magnetizable materials, otherwise the specified working distances will vary (e.g. reduction of approx. 20% with axial mounting on a magnetizable shaft).

Max. permitted radial offset ± 1.5 mm

radial offset

Operating temp. -40 ... +125°C

P/N	Pack. unit [pcs]
400005658	1
400056081	50

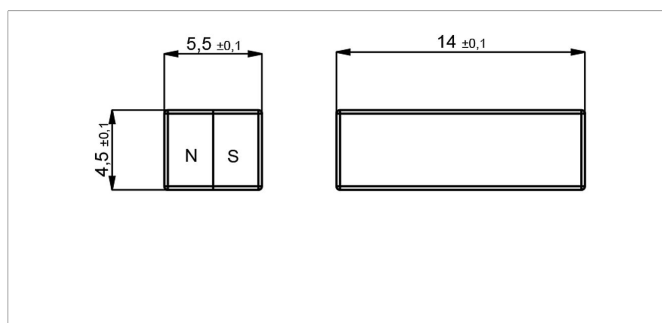

Z-RFC-P04

Magnet for direct application onto customer's shaft (see user manual).

We recommend mounting on non-magnetizable materials, otherwise the specified working distances will vary (e.g. reduction of approx. 20% with axial mounting on a magnetizable shaft).

Max. permitted radial offset ± 3 mm

radial offset

Operating temp. -40 ... +125°C

P/N	Pack. unit [pcs]
400005659	1
400056082	50

Position Markers

Working Distances Position Markers [mm] - One-channel Versions

Z-RFC-P03	Z-RFC-P04	Z-RFC-P18 / P28	Z-RFC-P19	Z-RFC-P20	Z-RFC-P22	Z-RFC-P23	Z-RFC-P30	Z-RFC-P31	Z-RFC-P43
1 ... 3	2.8 ... 6.2	0 ... 5	0 ... 2.8	2.8 ... 6.2	6.1 ... 10.9	2.8 ... 6.2	1.2 ... 2.7	2.8 ... 6.2	0.9 ... 3.4

Working Distances Position Markers [mm] - Redundant Versions

Z-RFC-P03	Z-RFC-P04	Z-RFC-P18 / P28	Z-RFC-P19	Z-RFC-P20	Z-RFC-P22	Z-RFC-P23	Z-RFC-P30	Z-RFC-P31	Z-RFC-P43
0.6 ... 2.6	2.8 ... 6.2	0 ... 4.5	0 ... 2.3	2.8 ... 6.2	5.6 ... 10.4	2.8 ... 6.2	0.7 ... 2.3	2.8 ... 6.2	0.5 ... 2.9

Lateral Magnet Offset

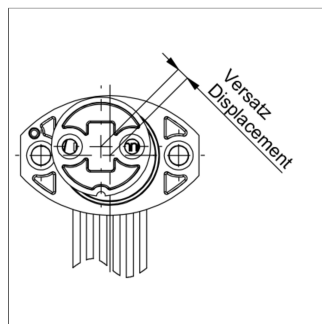

Lateral magnet offset will cause additional linearity error. The angle error, which is caused by radial displacement of sensor and position marker depends on the used position marker or magnet.

Additional Linearity Error at Radial Displacement - One-channel Versions

Z-RFC-P02 / P04 / P08 Z-RFC-P20 / P23 / P31	Z-RFC-P41 / P43 / P47	Z-RFC-P03 / P30	Z-RFC-P18 / P28	Z-RFC-P19	Z-RFC-P22
0.5 mm: $\pm 0.4^\circ$	0.5 mm: $\pm 0.4^\circ$	0.5 mm: $\pm 1.4^\circ$	0.5 mm: $\pm 0.7^\circ$	0.5 mm: $\pm 1.3^\circ$	1.0 mm: $\pm 0.8^\circ$
1.0 mm: $\pm 1.1^\circ$	1.0 mm: $\pm 1.1^\circ$	1.0 mm: $\pm 3.7^\circ$	1.0 mm: $\pm 1.3^\circ$	1.0 mm: $\pm 2.6^\circ$	2.0 mm: $\pm 1.8^\circ$
2.0 mm: $\pm 3.5^\circ$	2.0 mm: $\pm 3.5^\circ$	2.0 mm: -	2.0 mm: $\pm 3.3^\circ$	2.0 mm: -	4.0 mm: $\pm 5.4^\circ$

Additional Linearity Error at Radial Displacement - Redundant Versions

Z-RFC-P02 / P04 / P08 Z-RFC-P20 / P23 / P31	Z-RFC-P41 / P43 / P47	Z-RFC-P03 / P30	Z-RFC-P18 / P28	Z-RFC-P19	Z-RFC-P22
0.5 mm: $\pm 0.7^\circ$	0.5 mm: $\pm 0.7^\circ$	0.5 mm: $\pm 2.5^\circ$	0.5 mm: $\pm 1.1^\circ$	0.5 mm: $\pm 2.3^\circ$	1.0 mm: $\pm 1.1^\circ$
1.0 mm: $\pm 1.8^\circ$	1.0 mm: $\pm 1.8^\circ$	1.0 mm: $\pm 6.4^\circ$	1.0 mm: $\pm 2^\circ$	1.0 mm: $\pm 4.5^\circ$	2.0 mm: $\pm 2.4^\circ$
2.0 mm: $\pm 5.2^\circ$	2.0 mm: $\pm 5.2^\circ$	2.0 mm: -	2.0 mm: $\pm 4.6^\circ$	2.0 mm: -	4.0 mm: $\pm 6.7^\circ$

Signal Processing

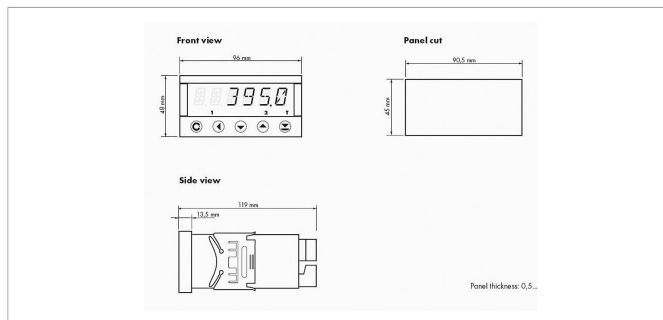

MAP-4000

Multifunctional measuring device with digital display for direct connection of potentiometric and normalized signals.

- Supply voltage 10...30 VDC, 80...250 VDC or AC
- High accuracy up to 0.1%
- Adjustable supply voltage for sensors 5...24 V
- Temperature coefficient 100 ppm/K
- Optional RS 232, RS 485, analog output, limited switch
- Complete data see separate data sheet

Connecting Options on request



- M12 connector**
- Customized lengths
 - 3-, 4-, 6- and 8-pole versions
 - Protection class IP68
 - Ordering codes of standard versions see ordering specifications

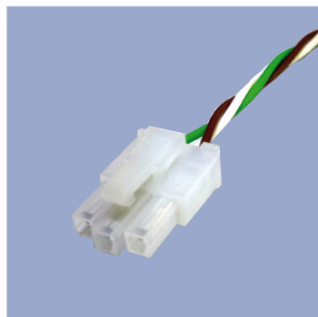

- Molex Mini Fit jr.**
- Customized length and lead wires
 - 3-, 4- and 6-pole versions
 - On request



- Tyco AMP Super Seal**
- Pin- and bushing housing
 - Customized lengths
 - 3-, 4- and 6-pole versions
 - Protection class IP67
 - On request



- Molex Mini Fit jr.**
- Customized length and lead wires
 - 3-, 4- and 6-pole versions
 - On request



- Deutsch DTM 04**
- Pin- and bushing housing
 - Customized lengths
 - 3-, 4- and 6-pole versions
 - Protection class IP67
 - On request



- ITT Cannon Sure Seal connector**
- Customized lengths
 - 3-, 4- and 6-pole versions
 - Protection class IP67
 - On request

Novotechnik
Messwertaufnehmer OHG
P.O.Box 4220
73745 Ostfildern (Germany)
Horbstrasse 12
73760 Ostfildern (Germany)
Phone +49 711 4489-0
Fax +49 711 4489-118
info@novotechnik.de
www.novotechnik.de



© Jan 10, 2023

The specifications contained in our datasheets are intended solely for informational purposes. The documented specification values are based on ideal operational and environmental conditions and can vary significantly depending on the actual customer application. Using our products at or close to one or more of the specified performance ranges can lead to limitations regarding other performance parameters. It is therefore necessary that the end user verifies relevant performance parameters in the intended application. We reserve the right to change product specifications without notice.