

Motor / Actuator Drivers for DC Brush Motor Series

# Automotive 6ch Half Bridge Driver with SPI Control

## BD16939AEFV-C

### General Description

The BD16939AEFV-C is 6ch half bridge driver for automotive applications. It can drive compact DC brush motors directly and each output can be controlled in three modes (High, Low and High Impedance).

MCU can control the driver via 16bit Serial Peripheral Interface (SPI). The absolute voltage is 40V rated with low ON resistance packaged in compact package, which contributes to realize high reliability, low energy consumption and low cost.

### Key Specifications

- Supply Voltage 6.3V to 32V
- Operating Temperature Range -40°C to +125°C
- Output Current 1.0A(Max)
- Output ON Resistance (High Side) 0.8Ω(Typ)
- Output ON Resistance (Low Side) 0.55Ω(Typ)

### Package

HTSSOP-B28

### W(Typ) x D(Typ) x H(Max)

9.70mm x 6.40mm x 1.00mm

### Features

- AEC-Q100 Qualified<sup>(Note 1)</sup>
- 1.0A DMOS Half Bridge 6 Circuits
- Three Mode Output Control (High, Low & High Impedance)
- Low Standby Current
- Built-in Protection Diode Against Output Reverse Voltage
- Over Current Protection at VS Supply Stage (OCP)
- Under Load Detection at VS Supply Stage (ULD)
- Over Voltage Protection with OVDSEL Mode at VS Supply Stage (OVP)
- Under Voltage Lock Out at VS Supply Stage (UVLO)
- Thermal Shutdown (TSD), Thermal Warning (TW)

(Note 1) Grade 1

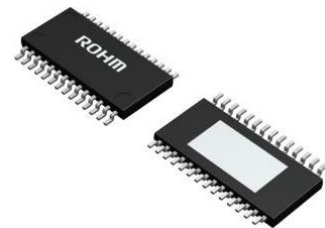

### Applications<sup>(Note 2)</sup>

Automotive Body Electronics, HVAC, Door Mirrors, etc.

### Typical Application Circuit

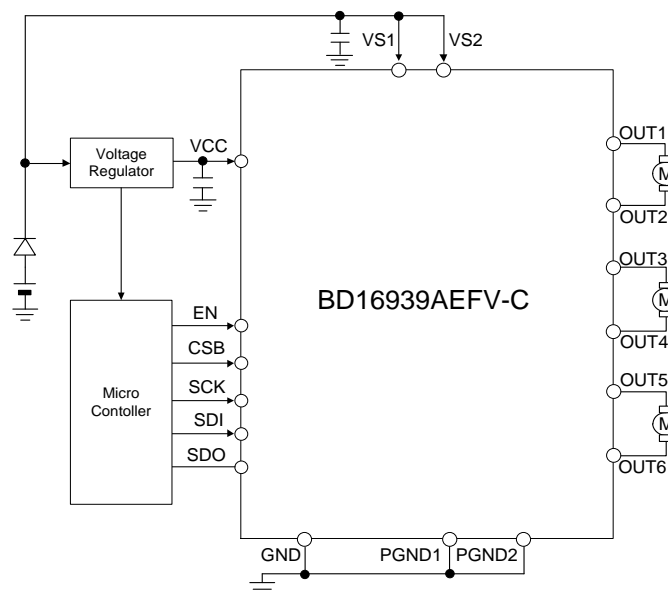

Figure 1. Typical Application Circuit

(Note 2) Please make sure you consult our company sales representative before mass production, if it is used except Door Mirror and HVAC.

## Pin Configuration

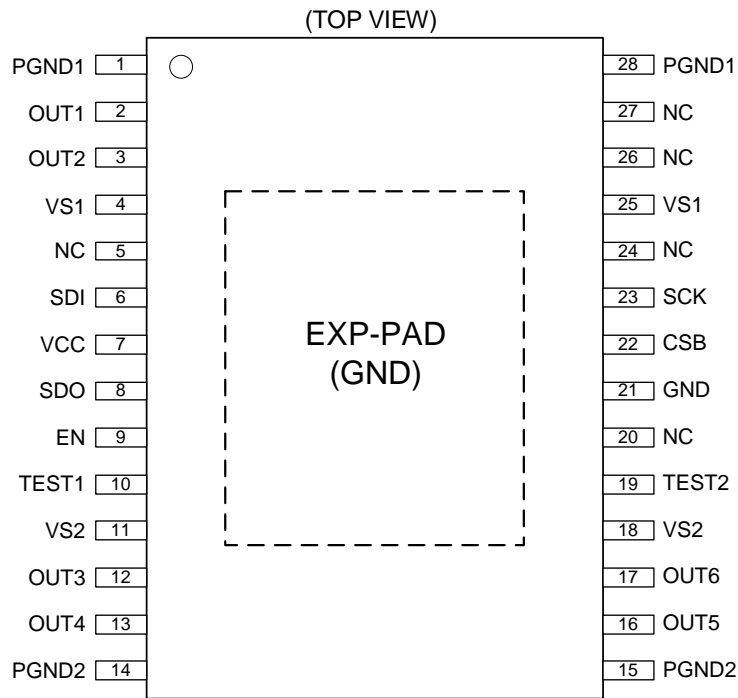

Figure 2. Pin Configuration

## Pin Description

Pin No.	Pin Name	Function	Pin No.	Pin Name	Function
1	PGND1	GND for output stages	28	PGND1	GND for output stages
2	OUT1	Half bridge output 1	27	NC	No Connection
3	OUT2	Half bridge output 2	26	NC	No Connection
4	VS1	Power supply for output stages	25	VS1	Power supply for output stages
5	NC	No Connection	24	NC	No Connection
6	SDI	SPI data input	23	SCK	SPI clock input
7	VCC	Logic supply	22	CSB	SPI chip select input
8	SDO	SPI data output	21	GND	Small signal GND
9	EN	Enable input	20	NC	No Connection
10	TEST1	Test mode input1 <sup>(Note 1)</sup>	19	TEST2	Test mode input2 <sup>(Note 1)</sup>
11	VS2	Power supply for output stages	18	VS2	Power supply for output stages
12	OUT3	Half bridge output 3	17	OUT6	Half bridge output 6
13	OUT4	Half bridge output 4	16	OUT5	Half bridge output 5
14	PGND2	GND for output stages	15	PGND2	GND for output stages
-	EXP-PAD	The EXP-PAD of the center of product connect to GND.			

(Note 1) Connect TEST1 and TEST2 to GND through a resistance

Block Diagram

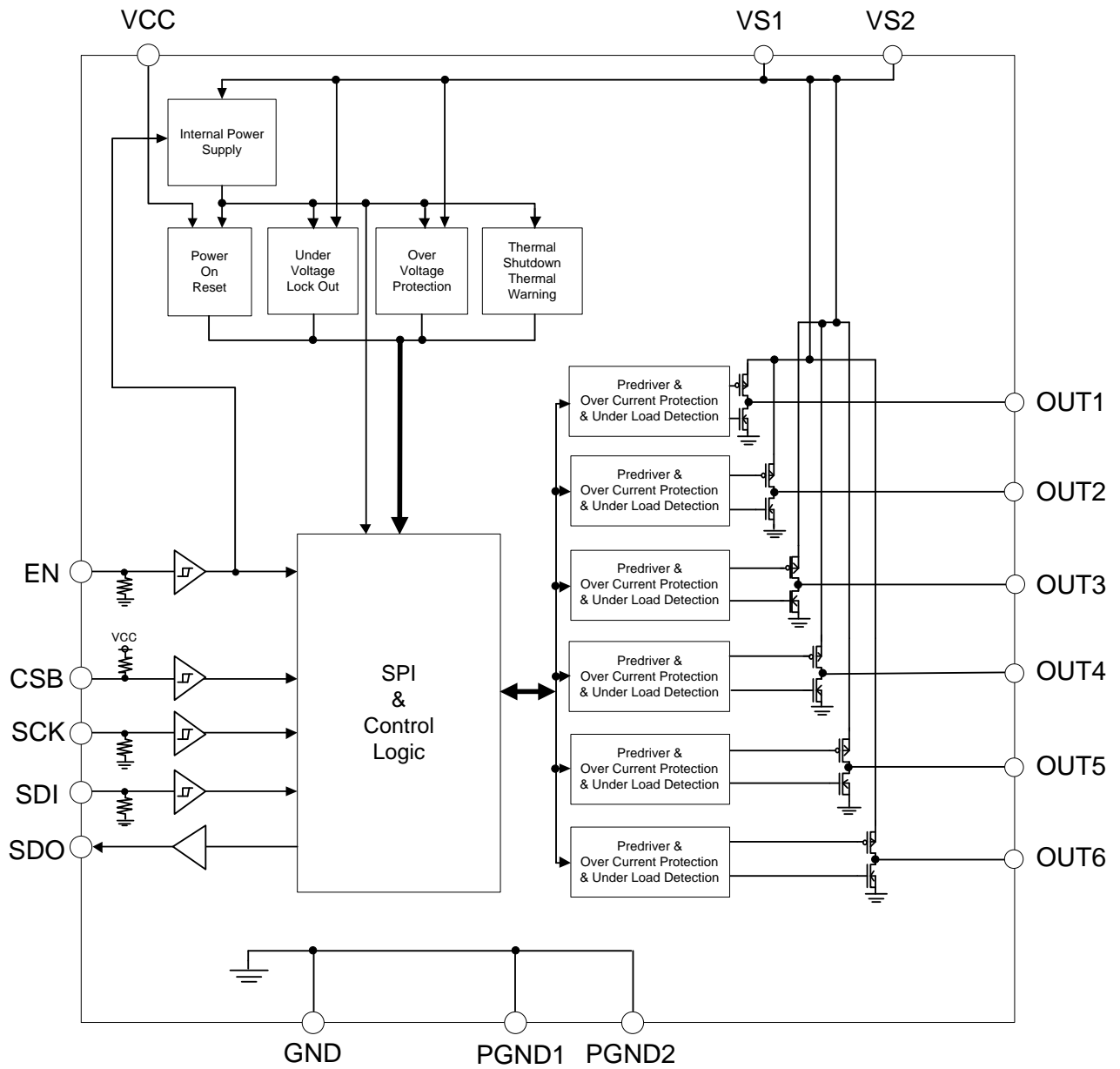

Figure 3. Block Diagram

## Absolute Maximum Ratings (Ta = 25°C)

Parameter	Symbol	Limit	Unit
Power Supply Voltage	V <sub>VS</sub> (Note 1)	-0.3 to +40	V
Logic Supply Voltage	V <sub>CC</sub>	-0.3 to +7.0	V
Output Voltage	V <sub>OUT1</sub> to V <sub>OUT6</sub>	-0.3 to +40	V
Output Current	I <sub>O</sub>	1.0	A
Logic Input Voltage	V <sub>SDI</sub> , V <sub>SCK</sub> , V <sub>CSB</sub> , V <sub>EN</sub>	-0.3 to V <sub>CC</sub> +0.3	V
Test Input Voltage	V <sub>TEST1</sub> , V <sub>TEST2</sub>	-0.3 to +40	V
Logic Output Voltage	V <sub>SDO</sub>	-0.3 to V <sub>CC</sub> +0.3	V
SDO Output Current	I <sub>SDO</sub>	5.0	mA
Storage Temperature Range	T <sub>stg</sub>	-55 to +150	°C
Maximum Junction Temperature	T <sub>jmax</sub>	150	°C

**Caution 1:** Operating the IC over the absolute maximum ratings may damage the IC. The damage can either be a short circuit between pins or an open circuit between pins and the internal circuitry. Therefore, it is important to consider circuit protection measures, such as adding a fuse, in case the IC is operated over the absolute maximum ratings.

**Caution 2:** Should by any chance the maximum junction temperature rating be exceeded the rise in temperature of the chip may result in deterioration of the properties of the chip. In case of exceeding this absolute maximum rating, design a PCB board with thermal resistance taken into consideration by increasing board size and copper area so as not to exceed the maximum junction temperature rating.

(Note 1) V<sub>VS</sub> = V<sub>VS1</sub>, V<sub>VS2</sub>

## Thermal Resistance (Note 2)

Parameter	Symbol	Thermal Resistance(Typ)		Unit
		1s(Note 4)	2s2p(Note 5)	
HTSSOP-B28				
Junction to Ambient	θ <sub>JA</sub>	107.0	25.1	°C/W
Junction to Top Characterization Parameter(Note 3)	ψ <sub>JT</sub>	6	3	°C/W

(Note 2) Based on JESD51-2A(Still-Air)

(Note 3) This thermal characterization parameter reports the difference between junction temperature and the temperature at the top center of the outside surface of the component package.

(Note 4) Using a PCB board based on JESD51-3.

(Note 5) Using a PCB board based on JESD51-5, 7.

Layer Number of Measurement Board	Material	Board Size
Single	FR-4	114.3mm x 76.2mm x 1.57mmt

Top	
Copper Pattern	Thickness
Footprints and Traces	70µm

Layer Number of Measurement Board	Material	Board Size	Thermal Via(Note 6)	
			Pitch	Diameter
4 Layers	FR-4	114.3mm x 76.2mm x 1.6mmt	1.20mm	Φ0.30mm

Top		2 Internal Layers		Bottom	
Copper Pattern	Thickness	Copper Pattern	Thickness	Copper Pattern	Thickness
Footprints and Traces	70µm	74.2mm x 74.2mm	35µm	74.2mm x 74.2mm	70µm

(Note 6) This thermal via connects with the copper pattern of all layers

## Recommended Operating Conditions

Parameter	Symbol	Min	Typ	Max	Unit
Operating Temperature	T <sub>opr</sub>	-40	+25	+125	°C
Power Supply Voltage(Note 7)	V <sub>VS</sub>	6.3	12	32	V
Logic Supply Voltage(Note 7)	V <sub>CC</sub>	3.0	5	5.5	V
Logic Input Voltage(Note 7)	V <sub>EN</sub> , V <sub>CSB</sub> , V <sub>SCK</sub> , V <sub>SDI</sub>	0	-	V <sub>CC</sub>	V

(Note 7) In order to start operation, apply the voltage to V<sub>CC</sub>(Logic supply voltage) after V<sub>S</sub>(Power supply voltage) exceeds the minimum operating voltage range (6.3V). After V<sub>CC</sub>(Logic supply voltage) exceeds the minimum operating voltage range(3.0V) then apply the voltage to the Logic input pins.

**Electrical Characteristics**(Unless otherwise specified,  $V_{VS} = 6.3V$  to  $32V$ ,  $V_{CC} = 3.0V$  to  $5.5V$ ,  $-40^{\circ}C \leq T_j \leq +150^{\circ}C$ )

Parameter	Symbol	Specification			Unit	Conditions
		Min	Typ	Max		
<b>Circuit Current</b>						
VS Circuit Current1	$I_{VS1}$	-	0	10	$\mu A$	EN = 0V
VS Circuit Current 2	$I_{VS2}$	-	5	10	mA	
VCC Circuit Current 1	$I_{VCC1}$	-	0	10	$\mu A$	EN = 0V
VCC Circuit Current 2	$I_{VCC2}$	-	0.1	0.5	mA	
<b>Output</b>						
Output ON Resistance High Side 1	$R_{ONH1}$	-	0.8	1.5	$\Omega$	$I_{Load} = 0.1A$ to $0.8A$ , $-40^{\circ}C \leq T_j < +25^{\circ}C$
Output ON Resistance High Side 2	$R_{ONH2}$	-	1.2	1.85	$\Omega$	$I_{Load} = 0.1A$ to $0.8A$ , $25^{\circ}C \leq T_j \leq 150^{\circ}C$
Output ON Resistance Low Side 1	$R_{ONL1}$	-	0.55	1.4	$\Omega$	$I_{Load} = 0.1A$ to $0.8A$ , $-40^{\circ}C \leq T_j < +25^{\circ}C$
Output ON Resistance Low Side 2	$R_{ONL2}$	-	1.1	1.65	$\Omega$	$I_{Load} = 0.1A$ to $0.8A$ , $25^{\circ}C \leq T_j \leq 150^{\circ}C$
Output Leakage High Side	$I_{LH}$	-	0	10	$\mu A$	OUT1 to OUT6 = 0V
Output Leakage Low Side	$I_{LL}$	-	0	10	$\mu A$	OUT1 to OUT6 = $V_{VS}$
Output Diode Voltage High Side	$V_{FH}$	0.2	0.8	1.4	V	$I_{Load} = 0.6A$
Output Diode Voltage Low Side	$V_{FL}$	0.2	0.8	1.4	V	$I_{Load} = -0.6A$
<b>Serial Input</b>						
Input High Voltage	$V_{IH}$	$V_{CC} \times 0.6$	-	-	V	
Input Low Voltage	$V_{IL}$	-	-	$V_{CC} \times 0.2$	V	
Input High Current 1	$I_{IH1}$	-	50	100	$\mu A$	(SDI, SCK, EN) = $V_{CC} = 5V$
Input High Current 2	$I_{IH2}$	-	0	10	$\mu A$	CSB = $V_{CC} = 5V$
Input Low Current 1	$I_{IL1}$	-	0	10	$\mu A$	(SDI, SCK, EN) = 0V
Input Low Current 2	$I_{IL2}$	-	50	100	$\mu A$	CSB = 0V, $V_{CC} = 5V$
<b>Serial Output</b>						
Output High Voltage	$V_{OH}$	$V_{CC} - 0.6$	-	-	V	$I_{Load} = -1.0mA$
Output Low Voltage	$V_{OL}$	-	-	0.6	V	$I_{Load} = 1.0mA$
<b>Protections</b>						
VS Under Voltage Lock Out (ON to OFF)	$V_{UVDH}$	5.3	5.8	6.3	V	
VS Under Voltage Lock Out (OFF to ON)	$V_{UVDL}$	5.0	5.5	6.0	V	
VS Over Voltage Protection1 (OFF to ON)	$V_{OVPH1}$	32.5	36	39.5	V	OVPSEL = 0
VS Over Voltage Protection 1 (ON to OFF)	$V_{OVPL1}$	30	33.5	37	V	OVPSEL = 0
VS Over Voltage Protection 2 (OFF to ON)	$V_{OVPH2}$	18	20	22	V	OVPSEL = 1
VS Over Voltage Protection 2 (ON to OFF)	$V_{OVPL2}$	16.2	18	19.8	V	OVPSEL = 1
VCC Power On Reset(ON to OFF)	$V_{PORH}$	2.6	2.8	3.0	V	
VCC Power On Reset(OFF to ON)	$V_{PORL}$	2.4	2.6	2.8	V	
Over Current Protection	$I_{OCP}$	1.05	1.55	2.05	A	
Over Current Protection Delay Time	$t_{DOC}$	10	25	50	$\mu s$	
Under Load Detection <sup>(Note 1)</sup>	$I_{UD}$	2	11	20	mA	
Under Load Detection Delay Time	$t_{DUD}$	200	370	600	$\mu s$	

(Note 1) Measured when there is no load in other channels.

**Electrical Characteristics – continued**

(Unless otherwise specified,  $V_{VS} = 6.3V$  to  $32V$ ,  $V_{CC} = 3.0V$  to  $5.5V$ ,  $-40^{\circ}C \leq T_j \leq +150^{\circ}C$ )

Parameter	Symbol	Specification			Unit	Conditions
		Min	Typ	Max		
<b>Protections</b>						
Thermal Warning <sup>(Note 1)</sup>	$T_{TW}$	100	125	150	$^{\circ}C$	
Thermal Warning Hysteresis <sup>(Note 1)</sup>	$T_{TWHYS}$	-	10	-	$^{\circ}C$	
Thermal Shutdown <sup>(Note 1)</sup>	$T_{TSD}$	150	175	200	$^{\circ}C$	
Thermal Shutdown Hysteresis <sup>(Note 1)</sup>	$T_{TSDHYS}$	-	25	-	$^{\circ}C$	
<b>Driver Output Timing</b>						
High Side Turn On Time	$t_{ONH}$	-	-	36.0	$\mu s$	$V_{VS} = 12V$ , No Load
Low Side Turn On Time	$t_{ONL}$	-	-	36.0	$\mu s$	$V_{VS} = 12V$ , No Load
OUT Rise Time	$t_{LHR}$	-	1.0	8.0	$\mu s$	$V_{VS} = 12V$ , No Load
OUT Fall Time	$t_{HLF}$	-	1.0	8.0	$\mu s$	$V_{VS} = 12V$ , No Load

(Note 1) Design guaranteed. No shipping inspection.

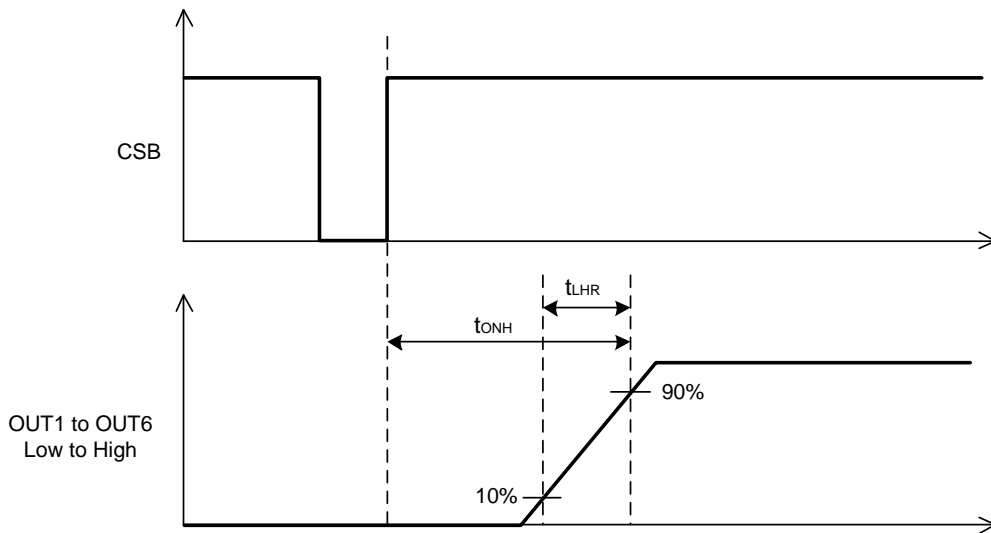

Figure 4. Driver Output Timing (Low to High)

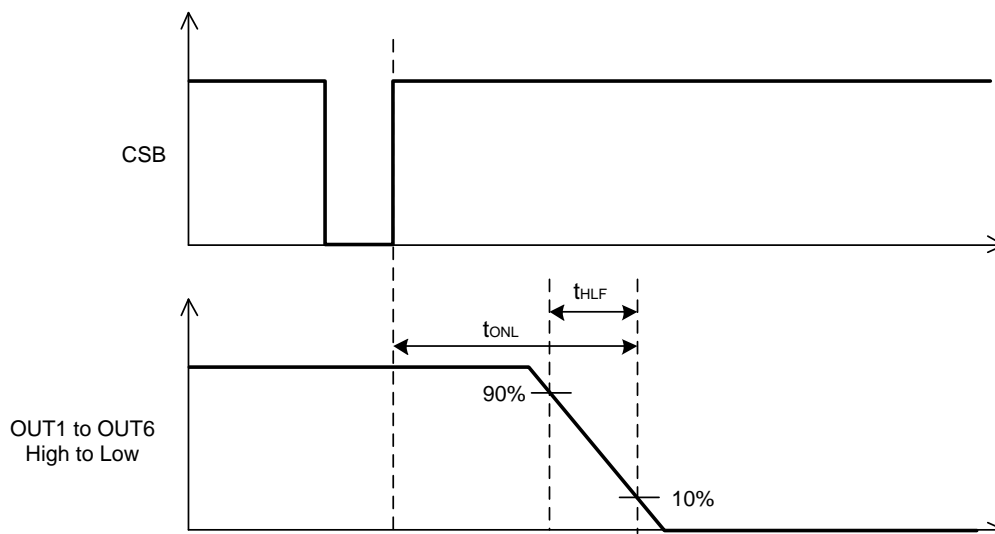

Figure 5. Driver Output Timing (High to Low)

**Electrical Characteristics – continued**

(Unless otherwise specified,  $V_{VS} = 6.3V$  to  $32V$ ,  $V_{CC} = 3.0V$  to  $5.5V$ ,  $-40^{\circ}C \leq T_j \leq +150^{\circ}C$ )

Parameter	Symbol	Specification			Unit	Conditions
		Min	Typ	Max		
<b>Serial Peripheral Interface</b>						
SCK Frequency	$f_{SCK}$	-	-	4.1	MHz	
SCK Period	$t_{SCK}$	243	-	-	ns	
SCK High Time	$t_{SCKH}$	87.5	-	-	ns	
SCK Low Time	$t_{SCKL}$	87.5	-	-	ns	
SCK Setup Time	$t_{SCKSET}$	125	-	-	ns	
SCK Hold Time	$t_{SCKHLD}$	125	-	-	ns	
CSB Lead Time	$t_{CSBLEAD}$	125	-	-	ns	
CSB Lag Time	$t_{CSBLAG}$	125	-	-	ns	
CSB High Time	$t_{CSBH}$	20	-	-	$\mu s$	
SDI Setup Time	$t_{SDISET}$	50	-	-	ns	
SDI Hold Time	$t_{SDIHLD}$	50	-	-	ns	
SDO Valid Time	$t_{SDOV}$	-	-	100	ns	No Load
SDO Enable After CSB Falling Edge	$t_{SDOEN}$	-	-	125	ns	(Note 1)
SDO Disable After CSB Rising Edge	$t_{SDODE}$	-	-	500	ns	(Note 1)

(Note 1) The timing is prescribed in 0% and 100% of  $V_{CC}$  to GND amplitude.

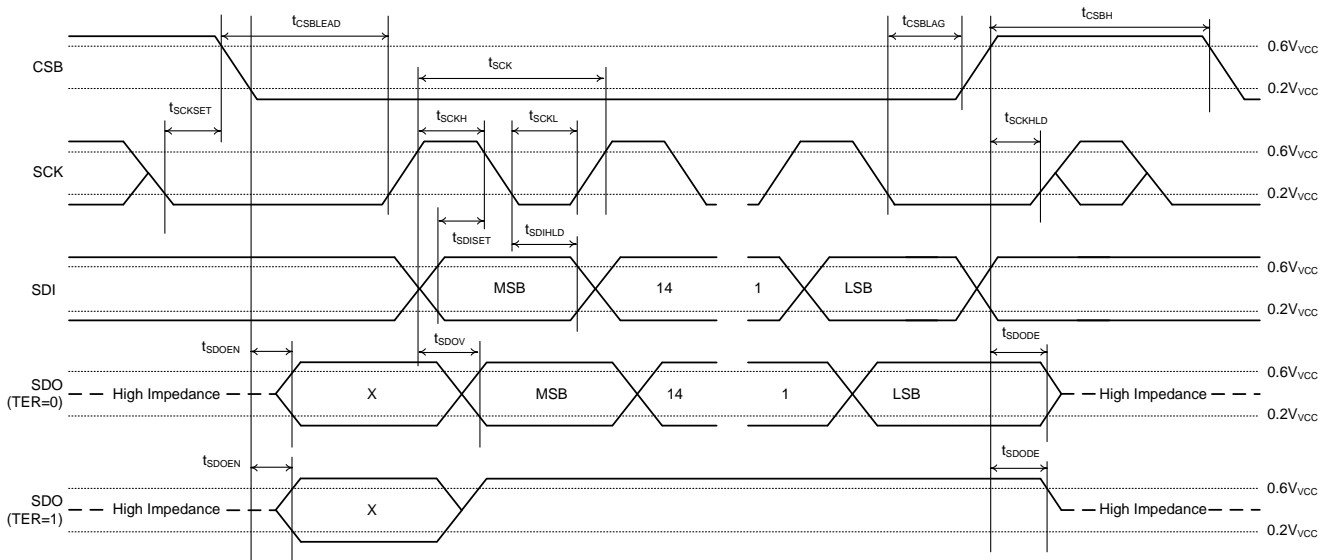

X: Unstable state  
 TER(Internal signal): "0" in normal operation / "1" in detecting erroneous SPI transmission

Figure 6. Serial Interface Timing

Typical Performance Curves

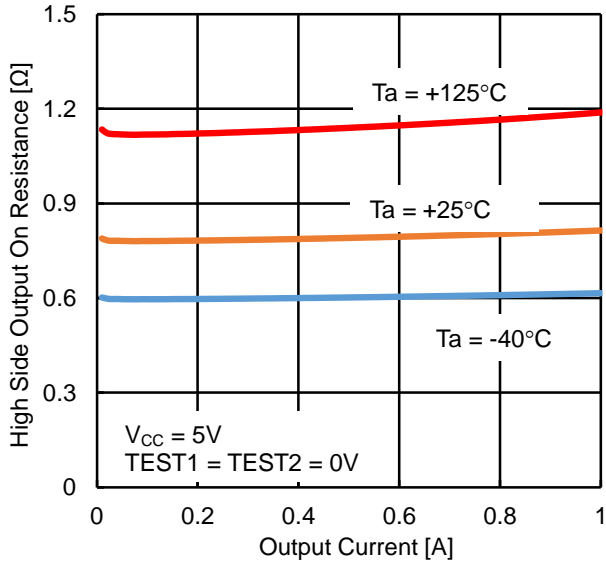

Figure 7. Output ON Resistance vs Output Current (Output ON Resistance High Side,  $V_{VS} = 12V$ )

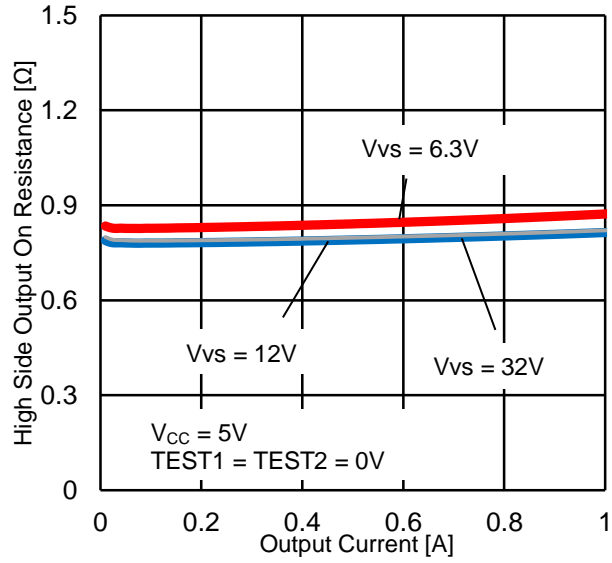

Figure 8. Output ON Resistance vs Output Current (Output ON Resistance High Side,  $T_a = 25^\circ C$ )

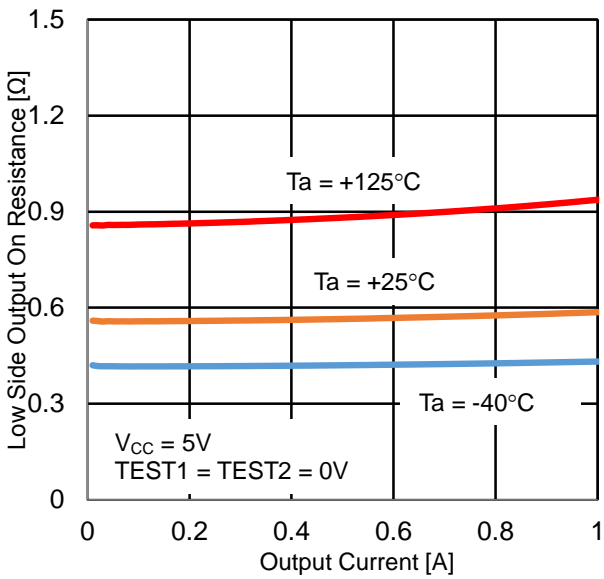

Figure 9. Output ON Resistance vs Output Current (Output ON Resistance Low Side,  $V_{VS} = 12V$ )

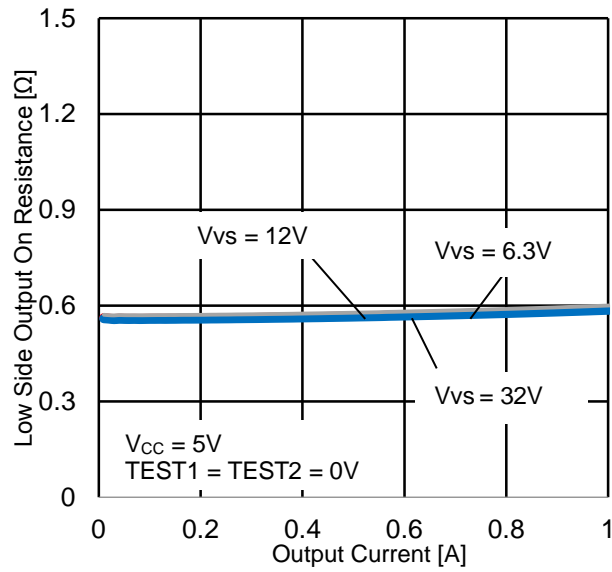

Figure 10. Output ON Resistance vs Output Current (Output ON Resistance Low Side,  $T_a = 25^\circ C$ )



## Description of Blocks

## 1. Serial Peripheral Interface: SPI

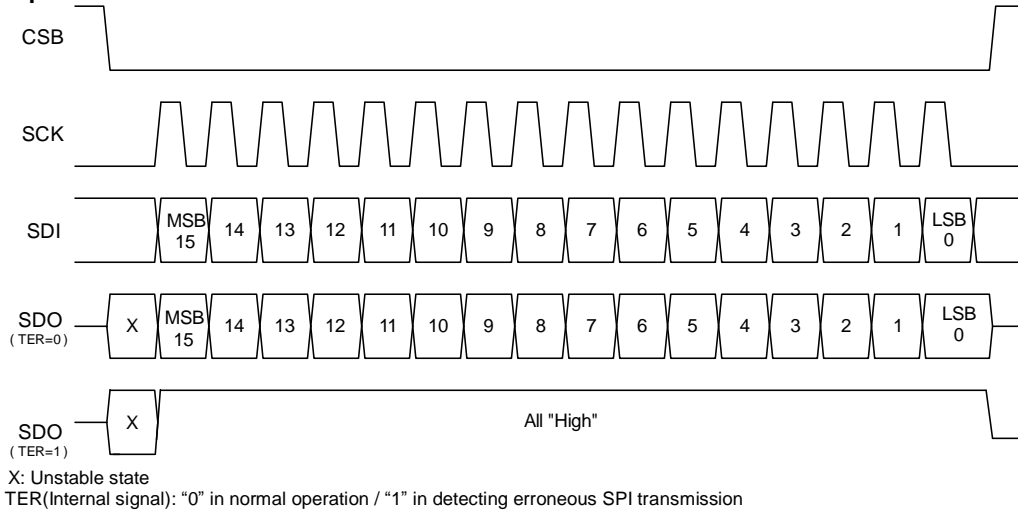

Figure 11. SPI Communication Format

16bit serial interface is equipped to control on / off of driver and various protections as well as to read out the state of protections. Input / Output register and the functions are described below.

## (1) Input Data Register1- Input Pattern Bit15 = 1, Bit14 = 0

Bit Number	Name	Description	Bit Status	Initial Value
15	WE	Write Enable	0 : Read 1 : Write & Read	-
14	WR_AD	Write Address	0 : Address A 1 : Address B	-
13	RD_AD	Read Address	0 : Address A 1 : Address B	-
12	SRR	Status Reset Register (This bit will self-clear)	0 : Normal 1 : Reset	0
11	HSC4	Control High Side 4 (OUT4)	0 : High Side Off 1 : High Side On	0
10	LSC4	Control Low Side 4 (OUT4)	0 : Low Side Off 1 : Low Side On	0
9	HSC3	Control High Side 3 (OUT3)	0 : High Side Off 1 : High Side On	0
8	LSC3	Control Low Side 3 (OUT3)	0 : Low Side Off 1 : Low Side On	0
7	HSC2	Control High Side 2 (OUT2)	0 : High Side Off 1 : High Side On	0
6	LSC2	Control Low Side 2 (OUT2)	0 : Low Side Off 1 : Low Side On	0
5	HSC1	Control High Side 1 (OUT1)	0 : High Side Off 1 : High Side On	0
4	LSC1	Control Low Side 1 (OUT1)	0 : Low Side Off 1 : Low Side On	0
3	UNDERLOAD	Under Loads Register Mode (OUT1 to OUT6)	0 : On 1 : Off	0
2	TSDSTH	TSDS Register Mode	0 : Latch 1 : Through	0
1	PSSTH	OVPS / UVLOS Register Mode	0 : Latch 1 : Through	0
0	RESERVE	Reserve	0 : Normal 1 : Prohibit	0

## Description of Blocks – continued

## (2) Input Data Register2- Input Pattern Bit15 = 1, Bit14 = 1

Bit Number	Name	Description	Bit Status	Initial Value
15	WE	Write Enable	0 : Read 1 : Write & Read	-
14	WR_AD	Write Address	0 : Address A 1 : Address B	-
13	RD_AD	Read Address	0 : Address A 1 : Address B	-
12	SRR	Status Reset Register (This bit will self-clear)	0 : Normal 1 : Reset	0
11	RESERVE	Reserve	-	-
10	RESERVE	Reserve	-	-
9	RESERVE	Reserve	-	-
8	RESERVE	Reserve	-	-
7	HSC6	Control High Side 6 (OUT6)	0 : High Side Off 1 : High Side On	0
6	LSC6	Control Low Side 6 (OUT6)	0 : Low Side Off 1 : Low Side On	0
5	HSC5	Control High Side 5 (OUT5)	0 : High Side Off 1 : High Side On	0
4	LSC5	Control Low Side 5 (OUT5)	0 : Low Side Off 1 : Low Side On	0
3	OVPSEL	OVP Threshold Select	0 : V <sub>OVPH1</sub> , V <sub>OVPL1</sub> 1 : V <sub>OVPH2</sub> , V <sub>OVPL2</sub>	0
2	RESERVE	Reserve	-	-
1	RESERVE	Reserve	-	-
0	RESERVE	Reserve	0 : Normal 1 : Prohibit	0

Input of High Side On and Low Side On is prohibited. The input of High Side On and Low Side On results in High Side Off and Low Side Off state.

If WE(Bit15: Write Enable) is set to '1', then Input Data Registers will be written and output will be Read Data as well depending on the previous SPI command.

It can select the Write Registers by setting WR\_AD(Bit14: Write Address) bit.

Read Data can be selected from the table of Read register by setting WR\_AD(Bit14: Write Address) and RD\_AD(Bit13: Read Address). For Read Data information, please refer below from Output Data Register1 to Output Data Register4.

If WE(Bit15: Write Enable) is set to '0', then Input Data Registers will not be written (the transferred write data Bits 12 to 0 in this case will be ignored) and output will be only Read Data depending on the previous SPI command setting of WR\_AD(Bit14: Write Address) and RD\_AD(Bit13: Read Address).

Daisy Chain input is not supported.

## Description of Blocks – continued

## (3) Output Data Register1- Input Pattern Bit15 = 0, Bit14 = 0, Bit13 = 0

Bit Number	Name	Description	Bit Status	Initial Value
15	-	-	-	0
14	TSDS	Thermal Shutdown Status	0 : Normal 1 : Fault	1 <sup>(Note 1)</sup>
13	TWS	Thermal Warning Status	0 : Normal 1 : Fault	1 <sup>(Note 1)</sup>
12	-	-	-	0
11	HSS4	Status High Side 4 (OUT4)	0 : High Side Off 1 : High Side On	0
10	LSS4	Status Low Side 4 (OUT4)	0 : Low Side Off 1 : Low Side On	0
9	HSS3	Status High Side 3 (OUT3)	0 : High Side Off 1 : High Side On	0
8	LSS3	Status Low Side 3 (OUT3)	0 : Low Side Off 1 : Low Side On	0
7	HSS2	Status High Side 2 (OUT2)	0 : High Side Off 1 : High Side On	0
6	LSS2	Status Low Side 2 (OUT2)	0 : Low Side Off 1 : Low Side On	0
5	HSS1	Status High Side 1 (OUT1)	0 : High Side Off 1 : High Side On	0
4	LSS1	Status Low Side 1 (OUT1)	0 : Low Side Off 1 : Low Side On	0
3	OCPS	Over Current Protection Status (OUT1 to OUT4)	0 : Normal 1 : Fault	1 <sup>(Note 1)</sup>
2	UNDERLOADS	Under Loads Status (OUT1 to OUT4)	0 : Normal 1 : Fault	1 <sup>(Note 1)</sup>
1	OVPS	Over Voltage Protection Status	0 : Normal 1 : Fault	1 <sup>(Note 1)</sup>
0	UVLOS	UVLO(VS) Status	0 : Normal 1 : Fault	1 <sup>(Note 1)</sup>

(Note 1) Default state is "1(Fault)". Set SRR register to "1" at the start which will reset this values.

## Description of Blocks – continued

## (4) Output Data Register2- Input Pattern Bit15 = 0, Bit14 = 0, Bit13 = 1

Bit Number	Name	Description	Bit Status	Initial Value
15	-	-	-	0
14	TSDS	Thermal Shutdown Status	0 : Normal 1 : Fault	1 <sup>(Note 1)</sup>
13	TWS	Thermal Warning Status	0 : Normal 1 : Fault	1 <sup>(Note 1)</sup>
12	-	-	-	0
11	UNDERLOAD4	Under Load Status OUT4	0 : Normal 1 : Fault	1 <sup>(Note 1)</sup>
10	UNDERLOAD3	Under Load Status OUT3	0 : Normal 1 : Fault	1 <sup>(Note 1)</sup>
9	UNDERLOAD2	Under Load Status OUT2	0 : Normal 1 : Fault	1 <sup>(Note 1)</sup>
8	UNDERLOAD1	Under Load Status OUT1	0 : Normal 1 : Fault	1 <sup>(Note 1)</sup>
7	OCPH4	Over Current Protection High Side Status OUT4	0 : Normal 1 : Fault	1 <sup>(Note 1)</sup>
6	OCPL4	Over Current Protection Low Side Status OUT4	0 : Normal 1 : Fault	1 <sup>(Note 1)</sup>
5	OCPH3	Over Current Protection High Side Status OUT3	0 : Normal 1 : Fault	1 <sup>(Note 1)</sup>
4	OCPL3	Over Current Protection Low Side Status OUT3	0 : Normal 1 : Fault	1 <sup>(Note 1)</sup>
3	OCPH2	Over Current Protection High Side Status OUT2	0 : Normal 1 : Fault	1 <sup>(Note 1)</sup>
2	OCPL2	Over Current Protection Low Side Status OUT2	0 : Normal 1 : Fault	1 <sup>(Note 1)</sup>
1	OCPH1	Over Current Protection High Side Status OUT1	0 : Normal 1 : Fault	1 <sup>(Note 1)</sup>
0	OCPL1	Over Current Protection Low Side Status OUT1	0 : Normal 1 : Fault	1 <sup>(Note 1)</sup>

(Note 1) Default state is "1(Fault)". Set SRR register to "1" at the start which will reset this values.

## Description of Blocks – continued

## (5) Output Data Register3- Input Pattern Bit15 = 0, Bit14 = 1, Bit13 = 0

Bit Number	Name	Description	Bit Status	Initial Value
15	-	-	-	0
14	TSDS	Thermal Shutdown Status	0 : Normal 1 : Fault	1 <sup>(Note 1)</sup>
13	TWS	Thermal Warning Status	0 : Normal 1 : Fault	1 <sup>(Note 1)</sup>
12	-	-	-	0
11	-	-	-	0
10	-	-	-	0
9	-	-	-	0
8	-	-	-	0
7	HSS6	Status High Side 6 (OUT6)	0 : High Side Off 1 : High Side On	0
6	LSS6	Status Low Side 6 (OUT6)	0 : Low Side Off 1 : Low Side On	0
5	HSS5	Status High Side 5 (OUT5)	0 : High Side Off 1 : High Side On	0
4	LSS5	Status Low Side 5 (OUT5)	0 : Low Side Off 1 : Low Side On	0
3	OCPS	Over Current Protection Status (OUT5 to OUT6)	0 : Normal 1 : Fault	1 <sup>(Note 1)</sup>
2	UNDERLOADS	Under Loads Status (OUT5 to OUT6)	0 : Normal 1 : Fault	1 <sup>(Note 1)</sup>
1	OVPS	Over Voltage Protection Status	0 : Normal 1 : Fault	1 <sup>(Note 1)</sup>
0	UVLOS	UVLO(VS) Status	0 : Normal 1 : Fault	1 <sup>(Note 1)</sup>

(Note 1) Default state is "1(Fault)". Set SRR register to "1" at the start which will reset this values.

## Description of Blocks – continued

## (6) Output Data Register4- Input Pattern Bit15 = 0, Bit14 = 1, Bit13 = 1

Bit Number	Name	Description	Bit Status	Initial Value
15	-	-	-	0
14	TSDS	Thermal Shutdown Status	0 : Normal 1 : Fault	1 (Note 1)
13	TWS	Thermal Warning Status	0 : Normal 1 : Fault	1 (Note 1)
12	-	-	-	0
11	-	-	-	0
10	-	-	-	0
9	UNDERLOAD6	Under Load Status OUT6	0 : Normal 1 : Fault	1 (Note 1)
8	UNDERLOAD5	Under Load Status OUT5	0 : Normal 1 : Fault	1 (Note 1)
7	-	-	-	0
6	-	-	-	0
5	-	-	-	0
4	-	-	-	0
3	OCPH6	Over Current Protection High Side Status OUT6	0 : Normal 1 : Fault	1 (Note 1)
2	OCPL6	Over Current Protection Low Side Status OUT6	0 : Normal 1 : Fault	1 (Note 1)
1	OCPH5	Over Current Protection High Side Status OUT5	0 : Normal 1 : Fault	1 (Note 1)
0	OCPL5	Over Current Protection Low Side Status OUT5	0 : Normal 1 : Fault	1 (Note 1)

(Note 1) Default state is "1(Fault)". Set SRR register to "1" at the start which will reset this values.

## Description of Blocks – continued

## (7) Settings of Error Output Registers

< PSSTH , TSDSTH >	Under Voltage Lock Out UVLOS	Over Voltage Protection OVPS	Thermal Shutdown TSDS	Over Current Protection OCPS
< 0 , 0 >	Latch	Latch	Latch	Latch
< 0 , 1 >	Latch	Latch	Self Recovery	Latch
< 1 , 0 >	Self Recovery	Self Recovery	Latch	Latch
< 1 , 1 >	Self Recovery	Self Recovery	Self Recovery	Latch

PSSTH, TSDSTH has to be set initially, and it shouldn't be changed in the middle of operation.

Either Latch or Self Recovery are selectable on UVLOS, OVPS and TSDS error output registers. Only Latch is available on OCPS error output register.

(The registers control only the operation mode of error output registers. It cannot change the operation of OUT1 to OUT6 terminals.)

Refer to the explanations of Protection Functions as far as OUT1 to OUT6 operations are concerned.

## (8) Erroneous SPI Transmission (Transmission Error: TER)

When CSB signal becomes Low to High it will be assumed that SPI has completed the transfer, and the internal registers will be updated. When SCK inputs high pulse of 16, 24, 32, ... (8+8xN values) except while CSB is low, erroneous SPI transmission is detected. If the error is detected, OUT1 to OUT6 outputs High Impedance and each error output register (OCPS, UNDERLOADS, TSDS, TWS, OVPS, and UVLOS) maintains the prior status accordingly. But SDO signal become high in the next transferring of SPI by TER.

At the same time, if the CSB High period ( $t_{CSBH}$ ) goes below the specified 20 $\mu$ s, an erroneous SPI transmission can be detected. The transmission error status is refreshed every time CSB rises.

TER(Internal signal) : "0" in normal operation / "1" in detecting erroneous SPI transmission

**Description of Blocks – continued**

**2. Over Voltage Protection (OVP)**

All outputs become High impedance if VS terminal voltage goes up to  $V_{OVPH}$  [when  $OVPSEL = 0$ ,  $V_{OVPH1} = 36V(Typ)$  and when  $OVPSEL = 1$ ,  $V_{OVPH2} = 20V(Typ)$ ] or above. And OVPS register is set '1'. Then, the outputs return to the normal operation when VS terminal voltage goes down to  $V_{OVPL}$  [when  $OVPSEL = 0$ ,  $V_{OVPL1} = 33.5V(Typ)$  and when  $OVPSEL = 1$ ,  $V_{OVPL2} = 18V(Typ)$ ] or below.

It can select either Latch mode or Self-Recovery mode for OVPS output register by PSSTH input register.

In case PSSTH input register is set '0', OVPS output register become Latch mode.

In case PSSTH input register is set '1', OVPS output register become Self-Recovery mode.

In case of Self-Recovery mode, OVPS output register return to '0' automatically, when VS terminal voltage goes down to  $V_{OVPL}$  or below. But, in case Latch mode, OPVS output register keeps '1', if VS terminal voltage goes down to  $V_{OVPL}$  or below. It can reset for the latch of OVPS by SRR register.

OVP doesn't operate when EN terminal is set to Low level. Please don't to exceed the absolute maximum power supply voltage to avoid the IC being destroyed.

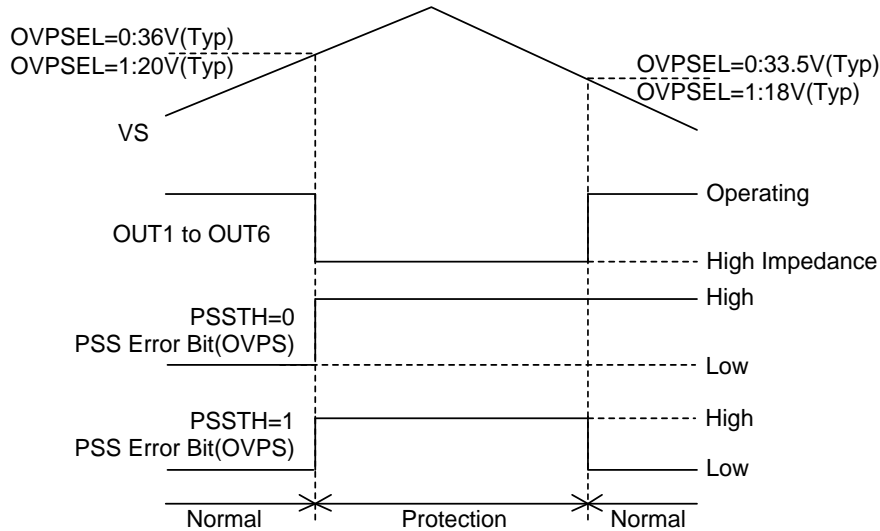

Figure 12. OVP Timing Chart

**3. Under Voltage Lock Out (UVLO)**

All outputs become High impedance if VS terminal voltage goes down to  $5.5V(Typ)$  or below. And UVLOS output register is set '1'. Then, when VS terminal voltage goes up to  $5.8V(Typ)$  or above, the outputs return to the normal operation mode.

It can select either Latch mode or Self-Recovery mode for UVLOS output register by PSSTH input register.

In case PSSTH input register is set '0', UVLOS output register become Latch mode.

In case PSSTH input register is set '1', UVLOS output register become Self-Recovery mode.

In case of Self-Recovery mode, UVLOS output register return to '0' automatically, when VS terminal voltage goes up to  $5.8V(Typ)$  or above. It can reset for the latch of UVLOS by SRR register.

However, all registers are reset and the outputs remains High impedance even if VS voltage goes back to normal voltage when VS power supply goes much lower than UVLO voltage. Because a digital circuit(SPI & Control Logic) works with an internal power supply which is made by VS power supply. Please set registers again.

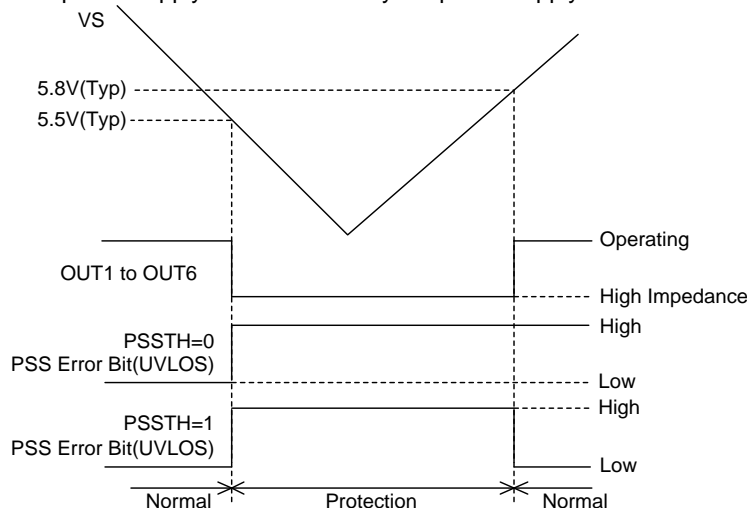

Figure 13. UVLO Timing Chart



Description of Blocks – continued

4. Over Current Protection (OCP)

If the current flows 1.55A(Typ) or above at the output terminal and pass 25µs(Typ), over current is protected. And OCPS register is set "1". Only the Over Current Protected output terminal is latched at High impedance. In order to release the latch, it has to be reset by SRR register or EN terminal. This 25µs delay time is implemented to avoid the malfunction caused by noise.

OCP function protects the IC from destruction caused by output short. However, the continuous overcurrent condition causes the IC heating up or degraded, thus please take the appropriate measure such as making this IC into stand-by mode by application program when over current condition continues. Register OCPH1 to OCPH6, OCPL1 to OCPL6 will be set to specify OCP condition for the respective channels. (Please refer the output data register tables.)

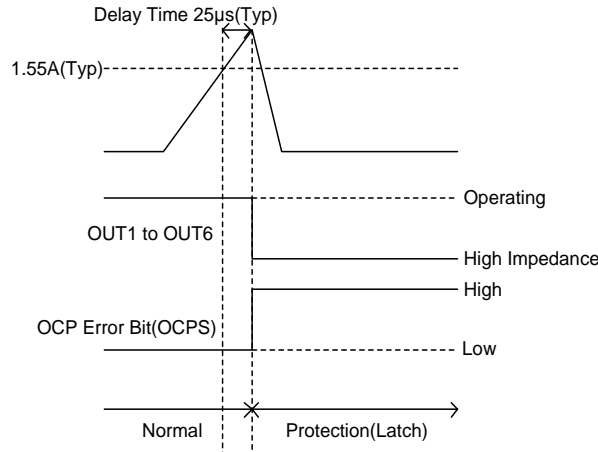

Figure 14. OCP Timing Chart

5. Thermal Shutdown (TSD) / Thermal Warning (TW)

If the junction temperature goes up to 175°C(Typ) or above, all outputs become High impedance. And TSDS output register is set '1'. Then, when the junction temperature goes down to 150°C(Typ) or below, the outputs return to the normal operation.

It can select either Latch mode or Self-Recovery mode for TSDS output register by TSDSTH input register.

In case TSDSTH input register is set '0', TSDS output register become Latch mode.

In case TSDSTH input register is set '1', TSDS output register become Self-Recovery mode.

In case of Self-Recovery mode, TSDS output register return to '0' automatically, when the junction temperature goes down to 150°C(Typ) or below. It can reset for the latch of TSDS by SRR register.

When the junction temperature goes up to 125°C(Typ) or above, TWS output register is set to '1'.

It can also select either Latch mode or Self-Recovery mode for TWS output register by TSDSTH input register.

In case TSDSTH input register is set '0', TWS output register become Latch mode.

In case TSDSTH input register is set '1', TWS output register become Self-Recovery mode.

In case of Self-Recovery mode, TWS output register return to '0' automatically, when the junction temperature goes down to 115°C(Typ) or below. It can reset for the latch of TWS by SRR register.

TW don't affect the output condition.

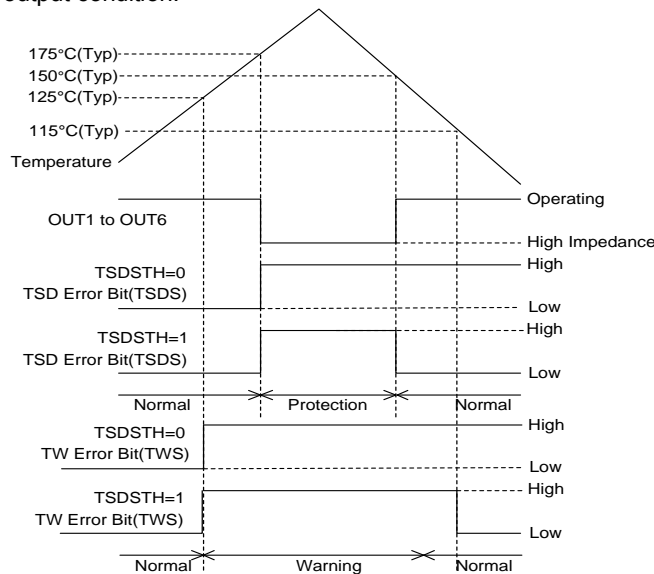

Figure 15. TSD / TW Timing Chart

Description of Blocks – continued

6. Under Load Detection (ULD)

When the current flows 11mA(Typ) or below at the output terminal and pass 370µs(Typ), Under Load is detected. And UNDERLOADS register is set '1'. The output is not turned off if Under Load is detected, but the fault is latched by the UNDERLOADS register. In order to release the latch, it has to be reset by SRR register. This 370µs delay time is implemented to avoid the malfunction caused by noise. Register UNDERLOAD1 to UNDERLOAD6 can be set to specify ULD condition for the respective channels. (Please refer the output data register tables.)

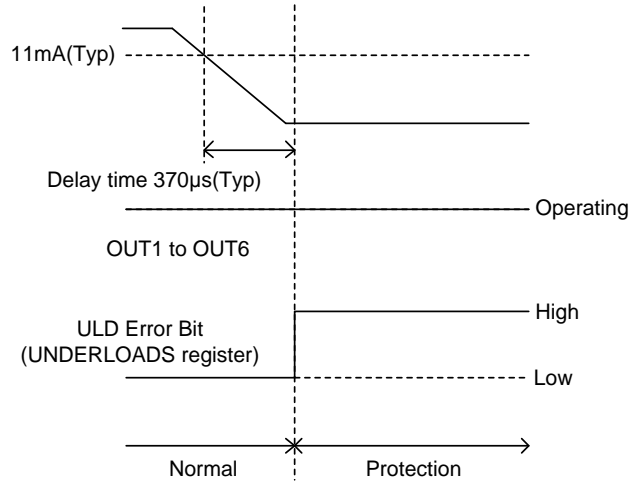

Figure 16. Under Load Timing Chart 1

(Note)

When use the motor that the detection time need more than 370µs(Typ) such as Figure 17, please set UNDERLOAD register to '1' at once, and then reset UNDERLOAD register to '0' after the load current becomes stable.

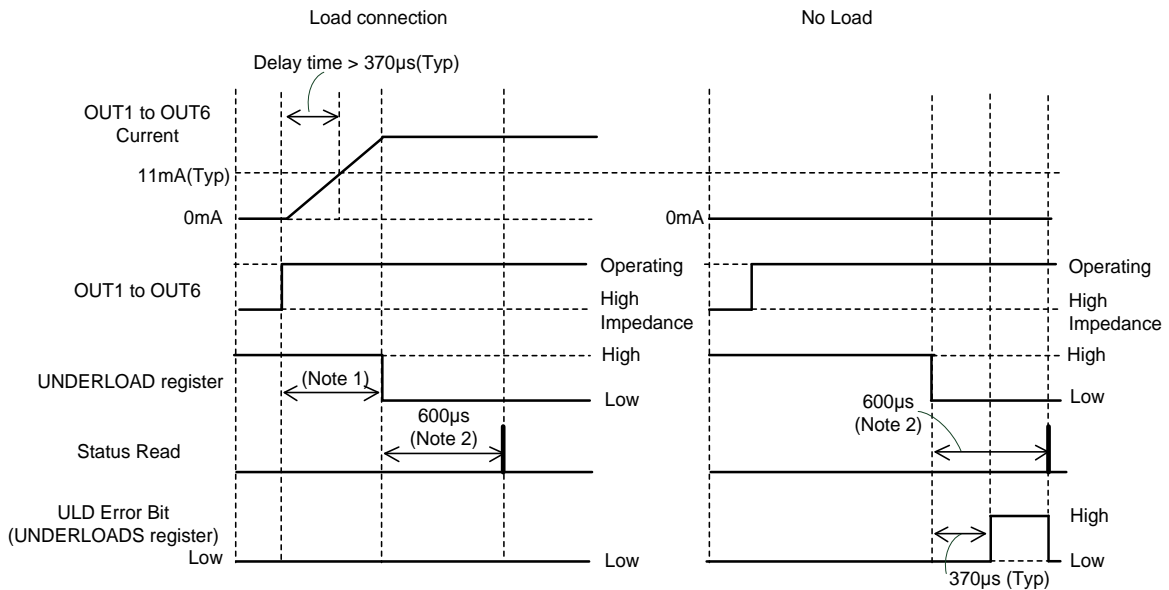
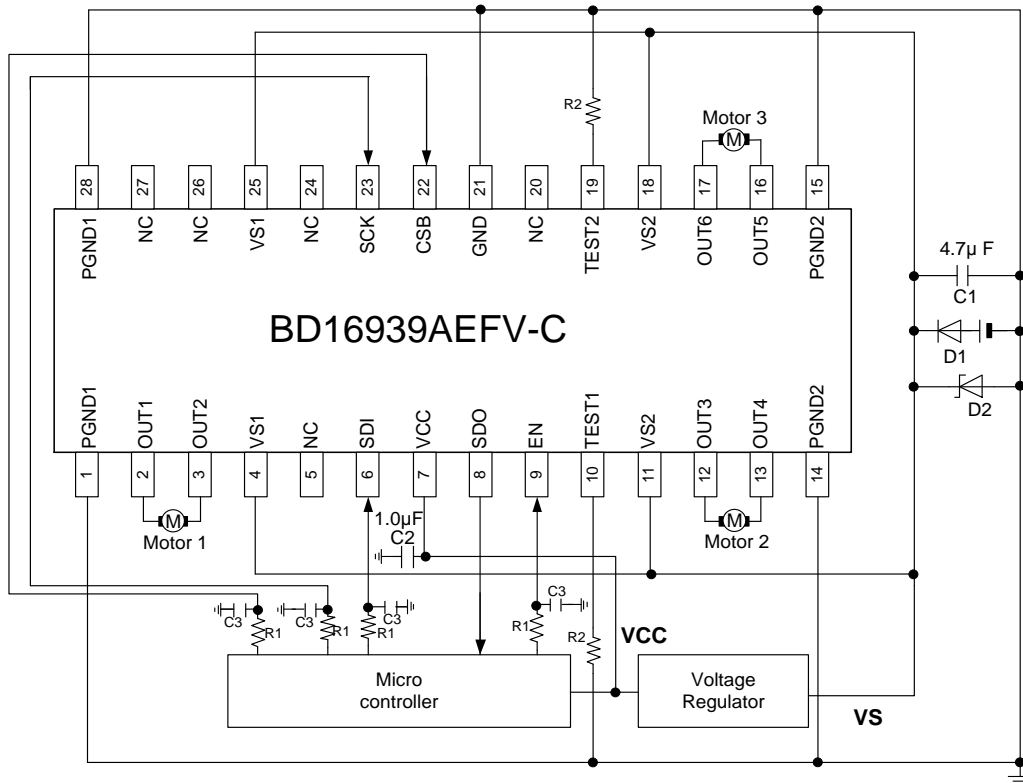

Figure 17. Under Load Timing Chart 2

(Note 1) This time should be determined based on response of the load connected.

(Note 2) OPEN detection time requires minimum 600µs, so please use it by an interval of at least 600µs.

## Recommended Application Example



The external circuit constants shown in the diagram above represent a recommended value, respectively. (NC terminal: OPEN)

Figure 18. Recommended Application Example

## Cautions on Designing of Application Circuits

## 1. Applicable Motors

Be noted that the BD16939AEFV-C motor driver can only drive DC motors and cannot drive stepping motors.

## 2. VS and VCC

Be sure to mount a power supply capacitor in the vicinity of the IC pins between the VS and PGND and between the VCC and GND. Determine the capacitance of the capacitor after fully ensuring that it presents no problems in characteristics. (The recommended value of between VS and GND is 4.7 $\mu$ F or more. The recommended value of between VCC and GND is 1.0 $\mu$ F or more.)

Cause a short circuit between VS (set them to the same potential) before using the IC.

## 3. Counter-Electromotive Force

The counter-electromotive force may vary with operating conditions and environment, and individual motor characteristics. Fully ensure that the counter-electromotive force presents no problems in the operation or the IC.

## 4. Fluctuations in Output Pin Voltage

If any output pin makes a significant fluctuation in the voltage to fall below GND potential due to heat generation conditions, power supply, motor to be used, and other conditions, this may result in malfunctions or other failures. In such cases, take appropriate measures, including the addition of a Schottky diode between the output pin and ground.

## 5. Rush Current

This IC has no built-in circuit that limits rush currents caused by applying current to the power supply or switching operation mode. To avoid the rush currents, take physical measures such as adding a current-limiting resistor between VS pins and the power supply.

## 6. Thermal Pad

Since a thermal pad is connected to the sub side of this IC, connect it to the ground potential. Do not use the thermal pad as ground interconnect.

I/O Equivalence Circuits

Pin No.	Pin Name	I/O Equivalence Circuit
6 9 23	SDI EN SCK	
8	SDO	
22	CSB	
2, 3 12, 13 16, 17	OUT1 to OUT6	
10 19	TEST1 TEST2	

The resistance values shown in the above diagram are typical values.

## Operational Notes

### 1. Reverse Connection of Power Supply

Connecting the power supply in reverse polarity can damage the IC. Take precautions against reverse polarity when connecting the power supply, such as mounting an external diode between the power supply and the IC's power supply pins.

### 2. Power Supply Lines

Design the PCB layout pattern to provide low impedance supply lines. Separate the ground and supply lines of the digital and analog blocks to prevent noise in the ground and supply lines of the digital block from affecting the analog block. Furthermore, connect a capacitor to ground at all power supply pins. Consider the effect of temperature and aging on the capacitance value when using electrolytic capacitors.

### 3. Ground Voltage

Ensure that no pins are at a voltage below that of the ground pin at any time, even during transient condition. However, pins that drive inductive loads (e.g. motor driver outputs, DC-DC converter outputs) may inevitably go below ground due to back EMF or electromotive force. In such cases, the user should make sure that such voltages going below ground will not cause the IC and the system to malfunction by examining carefully all relevant factors and conditions such as motor characteristics, supply voltage, operating frequency and PCB wiring to name a few.

### 4. Ground Wiring Pattern

When using both small-signal and large-current ground traces, the two ground traces should be routed separately but connected to a single ground at the reference point of the application board to avoid fluctuations in the small-signal ground caused by large currents. Also ensure that the ground traces of external components do not cause variations on the ground voltage. The ground lines must be as short and thick as possible to reduce line impedance.

### 5. Recommended Operating Conditions

The function and operation of the IC are guaranteed within the range specified by the recommended operating conditions. The characteristic values are guaranteed only under the conditions of each item specified by the electrical characteristics.

### 6. Inrush Current

When power is first supplied to the IC, it is possible that the internal logic may be unstable and inrush current may flow instantaneously due to the internal powering sequence and delays, especially if the IC has more than one power supply. Therefore, give special consideration to power coupling capacitance, power wiring, width of ground wiring, and routing of connections.

### 7. Testing on Application Boards

When testing the IC on an application board, connecting a capacitor directly to a low-impedance output pin may subject the IC to stress. Always discharge capacitors completely after each process or step. The IC's power supply should always be turned off completely before connecting or removing it from the test setup during the inspection process. To prevent damage from static discharge, ground the IC during assembly and use similar precautions during transport and storage.

### 8. Inter-pin Short and Mounting Errors

Ensure that the direction and position are correct when mounting the IC on the PCB. Incorrect mounting may result in damaging the IC. Avoid nearby pins being shorted to each other especially to ground, power supply and output pin. Inter-pin shorts could be due to many reasons such as metal particles, water droplets (in very humid environment) and unintentional solder bridge deposited in between pins during assembly to name a few.

### 9. Unused Input Pins

Input pins of an IC are often connected to the gate of a MOS transistor. The gate has extremely high impedance and extremely low capacitance. If left unconnected, the electric field from the outside can easily charge it. The small charge acquired in this way is enough to produce a significant effect on the conduction through the transistor and cause unexpected operation of the IC. So unless otherwise specified, unused input pins should be connected to the power supply or ground line.

## Operational Notes – continued

**10. Regarding the Input Pin of the IC**

This monolithic IC contains P+ isolation and P substrate layers between adjacent elements in order to keep them isolated. P-N junctions are formed at the intersection of the P layers with the N layers of other elements, creating a parasitic diode or transistor. For example (refer to figure below):

When  $GND > Pin A$  and  $GND > Pin B$ , the P-N junction operates as a parasitic diode.

When  $GND > Pin B$ , the P-N junction operates as a parasitic transistor.

Parasitic diodes inevitably occur in the structure of the IC. The operation of parasitic diodes can result in mutual interference among circuits, operational faults, or physical damage. Therefore, conditions that cause these diodes to operate, such as applying a voltage lower than the GND voltage to an input pin (and thus to the P substrate) should be avoided.

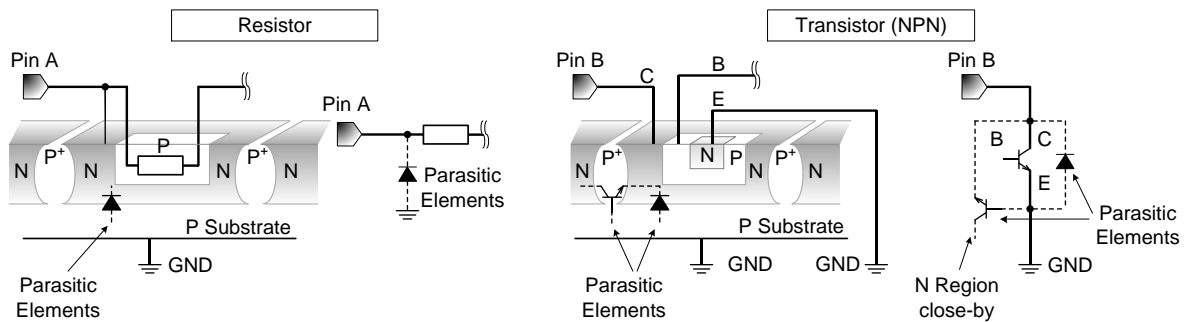

Figure 19. Example of monolithic IC structure

**11. Ceramic Capacitor**

When using a ceramic capacitor, determine a capacitance value considering the change of capacitance with temperature and the decrease in nominal capacitance due to DC bias and others.

**12. Thermal Shutdown Circuit (TSD)**

This IC has a built-in thermal shutdown circuit that prevents heat damage to the IC. Normal operation should always be within the IC's maximum junction temperature rating. If however the rating is exceeded for a continued period, the junction temperature ( $T_j$ ) will rise which will activate the TSD circuit that will turn OFF power output pins. When the  $T_j$  falls below the TSD threshold, the circuits are automatically restored to normal operation.

Note that the TSD circuit operates in a situation that exceeds the absolute maximum ratings and therefore, under no circumstances, should the TSD circuit be used in a set design or for any purpose other than protecting the IC from heat damage.

**13. Over Current Protection Circuit (OCP)**

This IC incorporates an integrated overcurrent protection circuit that is activated when the load is shorted. This protection circuit is effective in preventing damage due to sudden and unexpected incidents. However, the IC should not be used in applications characterized by continuous operation or transitioning of the protection circuit.

Ordering Information

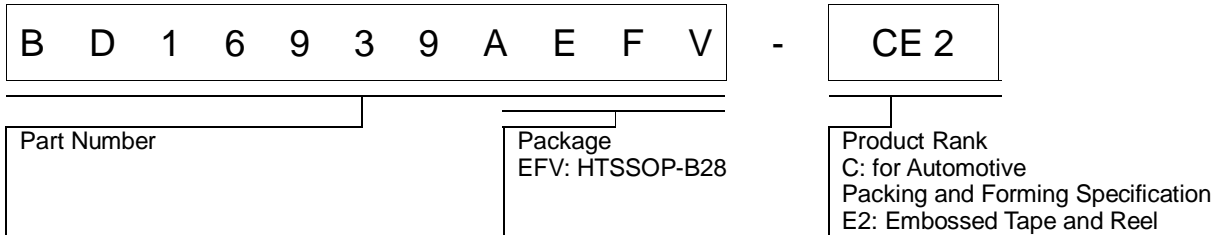

Marking Diagram

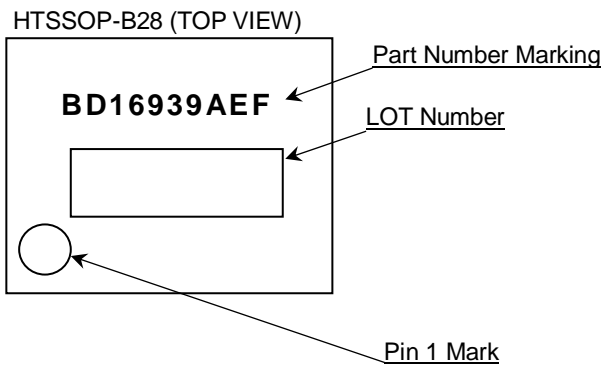





**Revision History**

Date	Revision	Changes
31.Aug.2019	001	New Release

# Notice

## Precaution on using ROHM Products

1. If you intend to use our Products in devices requiring extremely high reliability (such as medical equipment <sup>(Note 1)</sup>, aircraft/spacecraft, nuclear power controllers, etc.) and whose malfunction or failure may cause loss of human life, bodily injury or serious damage to property ("Specific Applications"), please consult with the ROHM sales representative in advance. Unless otherwise agreed in writing by ROHM in advance, ROHM shall not be in any way responsible or liable for any damages, expenses or losses incurred by you or third parties arising from the use of any ROHM's Products for Specific Applications.

(Note1) Medical Equipment Classification of the Specific Applications

JAPAN	USA	EU	CHINA
CLASS III	CLASS III	CLASS II b	CLASS III
CLASS IV		CLASS III	

2. ROHM designs and manufactures its Products subject to strict quality control system. However, semiconductor products can fail or malfunction at a certain rate. Please be sure to implement, at your own responsibilities, adequate safety measures including but not limited to fail-safe design against the physical injury, damage to any property, which a failure or malfunction of our Products may cause. The following are examples of safety measures:
  - [a] Installation of protection circuits or other protective devices to improve system safety
  - [b] Installation of redundant circuits to reduce the impact of single or multiple circuit failure
3. Our Products are not designed under any special or extraordinary environments or conditions, as exemplified below. Accordingly, ROHM shall not be in any way responsible or liable for any damages, expenses or losses arising from the use of any ROHM's Products under any special or extraordinary environments or conditions. If you intend to use our Products under any special or extraordinary environments or conditions (as exemplified below), your independent verification and confirmation of product performance, reliability, etc. prior to use, must be necessary:
  - [a] Use of our Products in any types of liquid, including water, oils, chemicals, and organic solvents
  - [b] Use of our Products outdoors or in places where the Products are exposed to direct sunlight or dust
  - [c] Use of our Products in places where the Products are exposed to sea wind or corrosive gases, including Cl<sub>2</sub>, H<sub>2</sub>S, NH<sub>3</sub>, SO<sub>2</sub>, and NO<sub>2</sub>
  - [d] Use of our Products in places where the Products are exposed to static electricity or electromagnetic waves
  - [e] Use of our Products in proximity to heat-producing components, plastic cords, or other flammable items
  - [f] Sealing or coating our Products with resin or other coating materials
  - [g] Use of our Products without cleaning residue of flux (Exclude cases where no-clean type fluxes is used. However, recommend sufficiently about the residue.); or Washing our Products by using water or water-soluble cleaning agents for cleaning residue after soldering
  - [h] Use of the Products in places subject to dew condensation
4. The Products are not subject to radiation-proof design.
5. Please verify and confirm characteristics of the final or mounted products in using the Products.
6. In particular, if a transient load (a large amount of load applied in a short period of time, such as pulse, is applied, confirmation of performance characteristics after on-board mounting is strongly recommended. Avoid applying power exceeding normal rated power; exceeding the power rating under steady-state loading condition may negatively affect product performance and reliability.
7. De-rate Power Dissipation depending on ambient temperature. When used in sealed area, confirm that it is the use in the range that does not exceed the maximum junction temperature.
8. Confirm that operation temperature is within the specified range described in the product specification.
9. ROHM shall not be in any way responsible or liable for failure induced under deviant condition from what is defined in this document.

## Precaution for Mounting / Circuit board design

1. When a highly active halogenous (chlorine, bromine, etc.) flux is used, the residue of flux may negatively affect product performance and reliability.
2. In principle, the reflow soldering method must be used on a surface-mount products, the flow soldering method must be used on a through hole mount products. If the flow soldering method is preferred on a surface-mount products, please consult with the ROHM representative in advance.

For details, please refer to ROHM Mounting specification

**Precautions Regarding Application Examples and External Circuits**

1. If change is made to the constant of an external circuit, please allow a sufficient margin considering variations of the characteristics of the Products and external components, including transient characteristics, as well as static characteristics.
2. You agree that application notes, reference designs, and associated data and information contained in this document are presented only as guidance for Products use. Therefore, in case you use such information, you are solely responsible for it and you must exercise your own independent verification and judgment in the use of such information contained in this document. ROHM shall not be in any way responsible or liable for any damages, expenses or losses incurred by you or third parties arising from the use of such information.

**Precaution for Electrostatic**

This Product is electrostatic sensitive product, which may be damaged due to electrostatic discharge. Please take proper caution in your manufacturing process and storage so that voltage exceeding the Products maximum rating will not be applied to Products. Please take special care under dry condition (e.g. Grounding of human body / equipment / solder iron, isolation from charged objects, setting of Ionizer, friction prevention and temperature / humidity control).

**Precaution for Storage / Transportation**

1. Product performance and soldered connections may deteriorate if the Products are stored in the places where:
  - [a] the Products are exposed to sea winds or corrosive gases, including Cl<sub>2</sub>, H<sub>2</sub>S, NH<sub>3</sub>, SO<sub>2</sub>, and NO<sub>2</sub>
  - [b] the temperature or humidity exceeds those recommended by ROHM
  - [c] the Products are exposed to direct sunshine or condensation
  - [d] the Products are exposed to high Electrostatic
2. Even under ROHM recommended storage condition, solderability of products out of recommended storage time period may be degraded. It is strongly recommended to confirm solderability before using Products of which storage time is exceeding the recommended storage time period.
3. Store / transport cartons in the correct direction, which is indicated on a carton with a symbol. Otherwise bent leads may occur due to excessive stress applied when dropping of a carton.
4. Use Products within the specified time after opening a humidity barrier bag. Baking is required before using Products of which storage time is exceeding the recommended storage time period.

**Precaution for Product Label**

A two-dimensional barcode printed on ROHM Products label is for ROHM's internal use only.

**Precaution for Disposition**

When disposing Products please dispose them properly using an authorized industry waste company.

**Precaution for Foreign Exchange and Foreign Trade act**

Since concerned goods might be fallen under listed items of export control prescribed by Foreign exchange and Foreign trade act, please consult with ROHM in case of export.

**Precaution Regarding Intellectual Property Rights**

1. All information and data including but not limited to application example contained in this document is for reference only. ROHM does not warrant that foregoing information or data will not infringe any intellectual property rights or any other rights of any third party regarding such information or data.
2. ROHM shall not have any obligations where the claims, actions or demands arising from the combination of the Products with other articles such as components, circuits, systems or external equipment (including software).
3. No license, expressly or implied, is granted hereby under any intellectual property rights or other rights of ROHM or any third parties with respect to the Products or the information contained in this document. Provided, however, that ROHM will not assert its intellectual property rights or other rights against you or your customers to the extent necessary to manufacture or sell products containing the Products, subject to the terms and conditions herein.

**Other Precaution**

1. This document may not be reprinted or reproduced, in whole or in part, without prior written consent of ROHM.
2. The Products may not be disassembled, converted, modified, reproduced or otherwise changed without prior written consent of ROHM.
3. In no event shall you use in any way whatsoever the Products and the related technical information contained in the Products or this document for any military purposes, including but not limited to, the development of mass-destruction weapons.
4. The proper names of companies or products described in this document are trademarks or registered trademarks of ROHM, its affiliated companies or third parties.

**General Precaution**

1. Before you use our Products, you are requested to carefully read this document and fully understand its contents. ROHM shall not be in any way responsible or liable for failure, malfunction or accident arising from the use of any ROHM's Products against warning, caution or note contained in this document.
2. All information contained in this document is current as of the issuing date and subject to change without any prior notice. Before purchasing or using ROHM's Products, please confirm the latest information with a ROHM sales representative.
3. The information contained in this document is provided on an "as is" basis and ROHM does not warrant that all information contained in this document is accurate and/or error-free. ROHM shall not be in any way responsible or liable for any damages, expenses or losses incurred by you or third parties resulting from inaccuracy or errors of or concerning such information.