

# Stepping Motors

Allowable Load ▶ p. 71 Internal Wiring, Rotation Direction ▶ p. 72  
General Specifications ▶ p. 73



## 14 mm sq.

1.8°/step **Ultra-compact** **RoHS**

Bipolar winding, Lead wire type

### Customizing

**Hollow** **Shaft modification**

Varies depending on the model number and quantity. Contact us for details.

### Bipolar winding, Lead wire type

Model no.		Holding torque at 2-phase energization	Rated current	Wiring resistance	Winding inductance	Rotor inertia	Mass	Motor length (L)
Single shaft	Dual shaft	N·m min.	A/phase	Ω/phase	mH/phase	×10 <sup>-4</sup> kg·m <sup>2</sup>	kg	mm
<b>SH2141-5541</b>	<b>SH2141-5511</b>	0.0065	0.3	21	4.2	0.00058	0.03	30
<b>SH2145-5641</b>	<b>SH2145-5611</b>	0.01	0.4	19	4	0.0011	0.042	43.8

### Characteristics diagram

#### SH2141-5541 SH2141-5511

Constant current circuit  
Source voltage: 24 VDC  
Operating current:  
0.3 A/phase, 2-phase  
energization (full-step)  
Pull-out torque:  
 $J_r=0.01 \times 10^{-4} \text{kg} \cdot \text{m}^2$  (pulley  
balancer method)  
fs: Maximum self-start  
frequency when not  
loaded

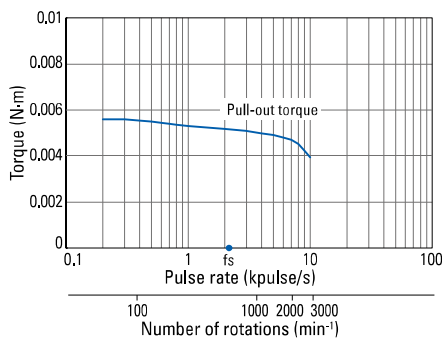

#### SH2145-5641 SH2145-5611

Constant current circuit  
Source voltage: 24 VDC  
Operating current:  
0.4 A/phase, 2-phase  
energization (full-step)  
Pull-out torque:  
 $J_r=0.01 \times 10^{-4} \text{kg} \cdot \text{m}^2$  (pulley  
balancer method)  
fs: Maximum self-start  
frequency when not  
loaded

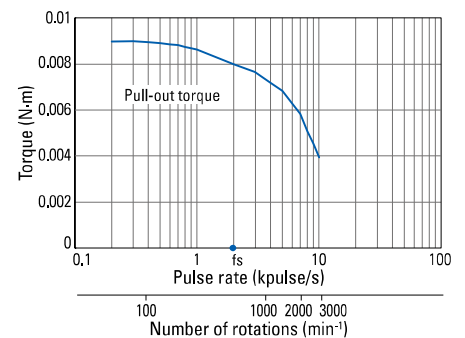

### Dimensions (Unit: mm)

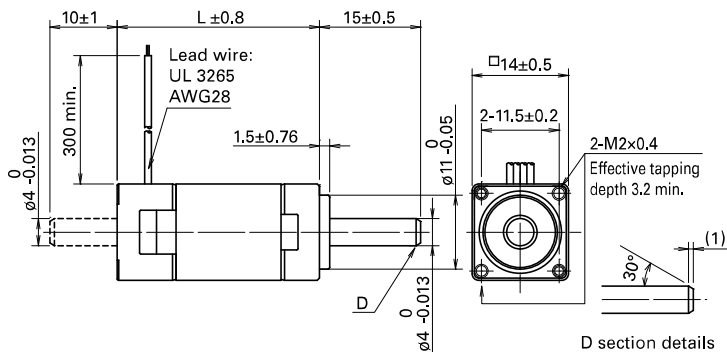

### Internal wiring

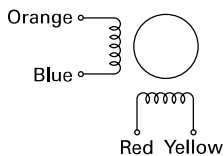

### Compatible drivers

Driver is not included.

If you require assistance finding a driver, contact us for details.

# Allowable Radial/Thrust Load

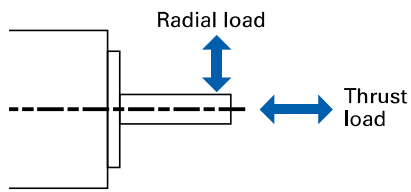

Motor size	Model no.	Distance from end of shaft: mm				Thrust load N
		0	5	10	15	
<b>14 mm sq.</b>	SH214 □	10	11	13	—	0.7
<b>28 mm sq.</b>	SH228 □	42	48	56	66	3
<b>35 mm sq.</b>	SH353 □	40	50	67	98	10
<b>42 mm sq.</b>	SF242 □	20	29	49	68	10
	SH142 □	22	26	33	46	
	SS242 □	10	—	—	—	4.9
<b>50 mm sq.</b>	103H670 □	71	87	115	167	15
	SS250 □	8.5	—	—	—	4.9
<b>56 mm sq.</b>	103H712 □	52	65	85	123	15
	103H7128	85	105	138	200	15
<b>60 mm sq.</b>	103H782 □	70	87	114	165	20
	SH160 □					15
<b>86 mm sq.</b>	SM286 □	167	193	229	280	60
	SH286 □					
<b>ø86 mm</b>	103H822 □	191	234	301	421	60
<b>ø106 mm</b>	103H8922 □	321	356	401	457	100

## Internal Wiring and Rotation Direction

### Unipolar winding

Connector type model no.: SF242

#### Internal wire connection

( ) connector pin number

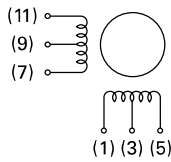

#### Direction of motor rotation

When excited by a direct current in the order shown below, the direction of rotation is clockwise as viewed from the output shaft side.

		Connector pin no.				
		(3, 9)	(1)	(7)	(5)	(11)
Exciting order	1	+	-	-		
	2	+		-	-	
	3	+			-	-
	4	+	-			-

Connector type model no.: 103H782

#### Internal wire connection

( ) connector pin number

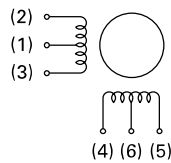

#### Direction of motor rotation

When excited by a direct current in the order shown below, the direction of rotation is clockwise as viewed from the output shaft side.

		Connector pin no.				
		(1, 6)	(4)	(3)	(5)	(2)
Exciting order	1	+	-	-		
	2	+		-	-	
	3	+			-	-
	4	+	-			-

Lead wire type

#### Internal wire connection

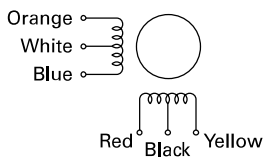

#### Direction of motor rotation

When excited by a direct current in the order shown below, the direction of rotation is clockwise as viewed from the output shaft side.

		Lead wire color				
		White, black	Red	Blue	Yellow	Orange
Exciting order	1	+	-	-		
	2	+		-	-	
	3	+			-	-
	4	+	-			-

### Bipolar winding

Connector type model no.: SF242

#### Internal wire connection

( ) connector pin number

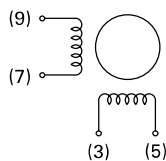

#### Direction of motor rotation

When excited by a direct current in the order shown below, the direction of rotation is clockwise as viewed from the output shaft side.

		Connector pin no.			
		(3)	(7)	(5)	(9)
Exciting order	1	-	-	+	+
	2	+	-	-	+
	3	+	+	-	-
	4	-	+	+	-

Connector type model no.: 103H782

#### Internal wire connection

( ) connector pin number

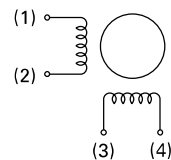

#### Direction of motor rotation

When excited by a direct current in the order shown below, the direction of rotation is clockwise as viewed from the output shaft side.

		Connector pin no.			
		(3)	(2)	(4)	(1)
Exciting order	1	-	-	+	+
	2	+	-	-	+
	3	+	+	-	-
	4	-	+	+	-

Lead wire type

#### Internal wire connection

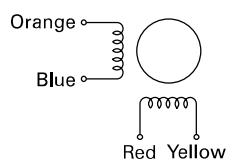

#### Direction of motor rotation

When excited by a direct current in the order shown below, the direction of rotation is clockwise as viewed from the output shaft side.

		Lead wire color			
		Red	Blue	Yellow	Orange
Exciting order	1	-	-	+	+
	2	+	-	-	+
	3	+	+	-	-
	4	-	+	+	-

# General Specifications

Motor model no.	SH214 <input type="checkbox"/>	SH228 <input type="checkbox"/>	SH353 <input type="checkbox"/>	SS242 <input type="checkbox"/>	SH142 <input type="checkbox"/>	SF242 <input type="checkbox"/>	SS250 <input type="checkbox"/>	103H670 <input type="checkbox"/>	103H712 <input type="checkbox"/>
Type	-								
Operating ambient temperature	-10 to +50°C								
Storage temperature	-20 to +65°C								
Operating ambient humidity	20 to 90% RH (no condensation)								
Storage humidity	5 to 95% RH (no condensation)								
Operation altitude	1000 m max. above sea level								
Vibration resistance	Vibration frequency 10 to 500 Hz, total amplitude 1.52 mm (10 to 70 Hz), vibration acceleration 150 m/s <sup>2</sup> (70 to 500 Hz), sweep time 15 min/cycle, 12 sweeps in each X, Y and Z direction.								
Impact resistance	500 m/s <sup>2</sup> of acceleration for 11 ms with half-sine wave applying three times for X, Y, and Z axes each, 18 times in total.								
Thermal class	Class B (+130°C)								
Withstandable voltage	At normal temperature and humidity, no failure with 500 VAC @50/60 Hz applied for one minute between motor winding and frame.							At normal temperature and humidity, no failure with 1000 VAC @50/60 Hz applied for one minute between motor winding and frame.	
Insulation resistance	At normal temperature and humidity, not less than 100 MΩ between winding and frame by 500 VDC megger.								
Protection grade	-								
Winding temperature rise	80 K max. (Based on SANYO DENKI standard)								
Static angle error	±0.09°				±0.054°		±0.09°		±0.054°
Thrust play *1	0.075 mm max. (load: 0.35 N)	0.075 mm max. (load: 1.5 N)	0.075 mm max. (load: 5 N)	0.075 mm max. (load: 4 N)	0.075 mm max. (load: 5 N)	0.075 mm (load: 5 N)	0.075 mm max. (load: 4 N)	0.075 mm (load: 10 N)	0.075 mm (load: 10 N)
Radial play *2	0.025 mm max. (load: 5 N)								
Shaft runout	0.025 mm								
Concentricity of mounting pilot relative to shaft	ø0.05 mm	ø0.05 mm	ø0.075 mm	ø0.075 mm	ø0.05 mm	ø0.05 mm	ø0.075 mm	ø0.075 mm	ø0.075 mm
Squareness of mounting surface relative to shaft	0.1 mm	0.1 mm	0.1 mm	0.1 mm	0.1 mm	0.1 mm	0.1 mm	0.075 mm	0.075 mm
Direction of motor mounting	Can be freely mounted vertically or horizontally								

Motor model no.	SH160 <input type="checkbox"/>	103H782 <input type="checkbox"/>	SH286 <input type="checkbox"/>	103H8922 <input type="checkbox"/>	SM286 <input type="checkbox"/>	103H712 <input type="checkbox"/> -6 <input type="checkbox"/> 0 CE Model	103H822 <input type="checkbox"/> -6 <input type="checkbox"/> 0 CE Model	103H8922 <input type="checkbox"/> -63 <input type="checkbox"/> 1 CE Model	
Type	-				S1 (continuous operation)				
Operating ambient temperature	-10 to +50°C				-10 to +40°C				
Storage temperature	-20 to +65°C				-20 to +60°C				
Operating ambient humidity	20 to 90% RH (no condensation)				95% RH max. at 40°C or less (no condensation)				
Storage humidity	5 to 95% RH (no condensation)				95% RH max. at 40°C or less, 57% RH max. at 50°C or less, 35% RH max. at 60°C or less (no condensation)				
Operation altitude	1000 m max. above sea level								
Vibration resistance	Vibration frequency 10 to 500 Hz, total amplitude 1.52 mm (10 to 70 Hz), vibration acceleration 150 m/s <sup>2</sup> (70 to 500 Hz), sweep time 15 min/cycle, 12 sweeps in each X, Y and Z direction.								
Impact resistance	500 m/s <sup>2</sup> of acceleration for 11 ms with half-sine wave applying three times for X, Y and Z axes each, 18 times in total.								
Thermal class	Class B (+130°C)				Class F (+155°C)	Class B (+130°C)			
Withstandable voltage	At normal temperature and humidity, no failure with 1000 VAC @50/60 Hz applied for one minute between motor winding and frame.				At normal temperature and humidity, no failure with 1500 VAC @50/60 Hz applied for one minute between motor winding and frame.				
Insulation resistance	At normal temperature and humidity, not less than 100 MΩ between winding and frame by 500 VDC megger.								
Protection grade	-				IP43				
Winding temperature rise	80 K max. (Based on SANYO DENKI standard)								
Static angle error	±0.054°		±0.09°		±0.054°		±0.09°		
Thrust play *1	0.075 mm max. (load: 10 N)								
Radial play *2	0.025 mm (load: 5 N)	0.025 mm (load: 5 N)	0.025 mm (load: 5 N)	0.025 mm (load: 10 N)	0.025 mm (load: 5 N)	0.025 mm (load: 5 N)	0.025 mm (load: 5 N)	0.025 mm (load: 10 N)	0.025 mm (load: 10 N)
Shaft runout	0.025 mm								
Concentricity of mounting pilot relative to shaft	ø0.075 mm								
Squareness of mounting surface relative to shaft	0.1 mm	0.075 mm	0.15 mm	0.1 mm	0.15 mm	0.075 mm	0.1 mm	0.1 mm	0.1 mm
Direction of motor mounting	Can be freely mounted vertically or horizontally								

\*1 Thrust play: Shaft displacement under axial load.

\*2 Radial play: Shaft displacement under radial load applied 1/3rd of the length from the end of the shaft.

## Safety standards

Model no.: SM286  CE/UL marked models

CE (TÜV)	Standard category		Applicable standard
	Low-voltage directives		EN 60034-1, EN 60034-5
UL	Acquired standards	Applicable standard	File no.
	UL	UL 1004-1, UL 1004-6	E179832
	UL for Canada	CSA C22.2 No.100	

Model no.: 103H712  -6  0, 103H822  -6  0, 103H8922  -63  1 CE marked model

CE (TÜV)	Standard category		Applicable standard
	Low-voltage directives		EN 60034-1, EN 60034-5