

THIS DOCUMENT IS THE PROPERTY OF KEYSTONE ELECTRONICS CORP. AND SHALL NOT BE REPRODUCED, DISTRIBUTED OR USED AS A BASIS FOR MANUFACTURE WITHOUT PRIOR WRITTEN PERMISSION FROM KEYSTONE ELECTRONICS CORP.

REQUIRED SPACING FOR 'AA' CLIP

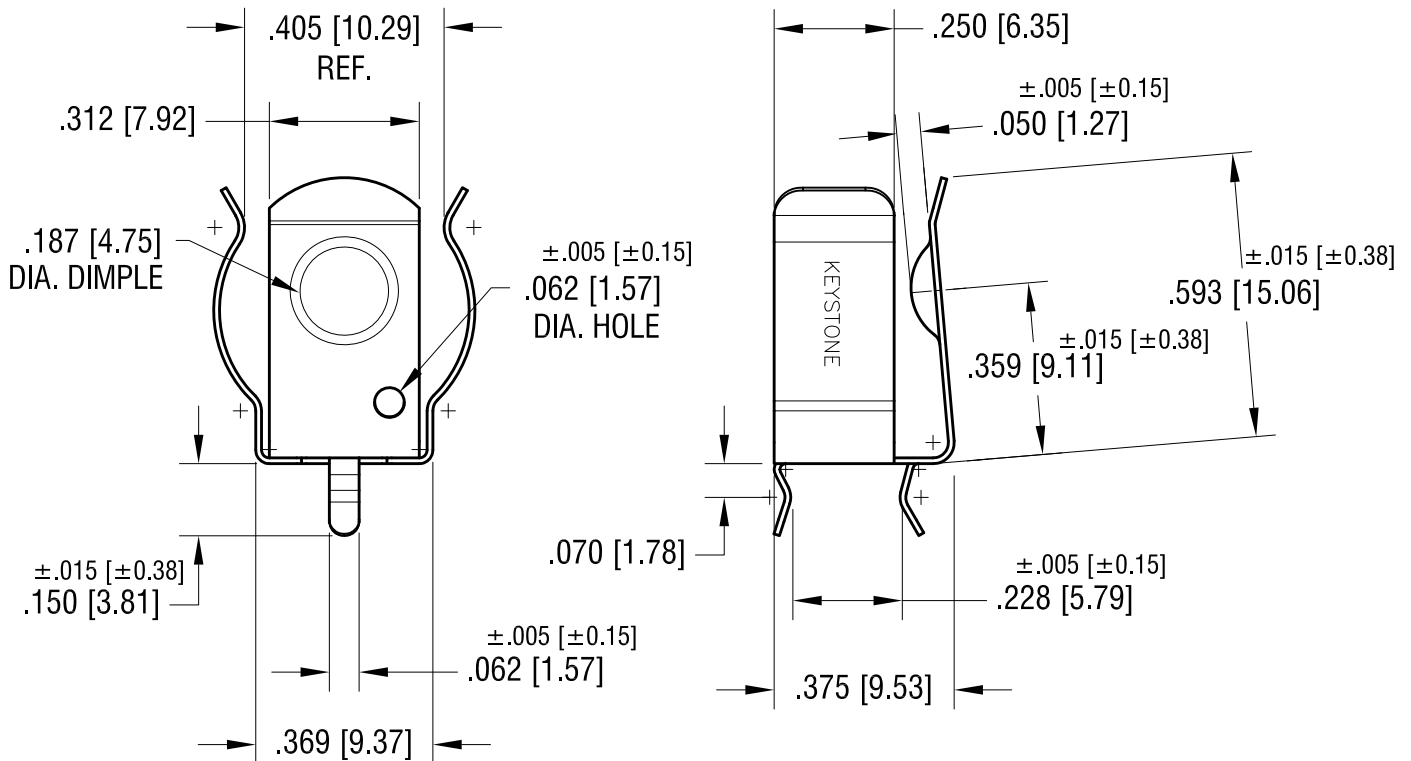
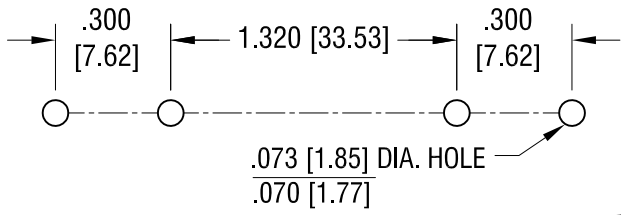

NOTE:

1. HEAT TREAT TO SPRING TEMPER.

KEYSTONE ELECTRONICS CORP.

www.keyelco.com • ASTORIA, N.Y. 11105-2017 • Tel (718) 956-8900

PART NAME

'A' & 'AA' PC BATTERY CLIP

MATERIAL

.012 [.30] TH'K ANNEALED SPRING STEEL

FINISH

TIN NICKEL PLATE

DRN BY

BOONE

DATE

4.26.89

APP'D

LN

SCALE

2.5X

TOLERANCES

INCH [MM]

DECIMAL

±.010 [±0.25]

ANGULAR

± 2°

UNLESS OTHERWISE SPECIFIED

CODE

C

DWG NO.

92

DATE	DESCRIPTION	REV.
9.06.16	CHANGE AS PER ECR 16-065	N
9.01.16	CHANGE AS PER ECN16-083	M
7.11.14	CHANGE AS PER ECN14-065	L
6.19.06	CHANGE AS PER ECN 06-038	K