

# San Ace 160AD

9ADW type

## ACDC Fan

### Features

#### High Airflow and High Static Pressure

This fan delivers a maximum airflow of 8.2 m<sup>3</sup>/min and maximum static pressure of 167 Pa.

#### Low Noise and Low Power Consumption

This fan operate with a noise level of 58 dB(A) and power consumption of 22 W. Also, the PWM control function enables the control of fan speed, contributing to lowering noise and improving energy efficiency of devices.

#### Wide Operating Voltage Range

This fan has an input voltage range of 100 to 240 VAC, supporting both 100 and 200 VAC systems.

#### Water and Dust Protection

This fan achieves excellent IP56\* water and dust protection, maintaining stable operation in harsh environments.

\*The degree of protection (IP code) is defined by IEC 60529 (International Electrotechnical Commission).  
The protection rating applies only to electrical components (motor coils and electronic components) in our fans.  
The mechanical components other than the electrical components are not subject to protection.



**160 x 160 x 51 mm**

### Specifications

#### Lead wire model

The models listed below **have pulse sensors with PWM control function.**

Model no.	Rated voltage [V]	Operating voltage range [V]	Frequency [Hz]	PWM duty cycle* [%]	Rated current [A]	Rated input [W]	Rated speed [min <sup>-1</sup> ]	Max. airflow [m <sup>3</sup> /min] [CFM]	Max. static pressure [Pa] [inchH <sub>2</sub> O]	SPL [dB(A)]	Operating temperature [°C]	Expected life [h]
9ADW1601P5H003	100 to 240	90 to 264	50/60	100	0.46	22	4150	8.2 290	167 0.66	58	-20 to +70	40000/60°C (70000/40°C)
				0	0.10	4.0	1500	3.07 108	44 0.17	31		

\* PWM frequency is 25 kHz. Models without ratings for 0% PWM duty cycle have zero speed at 0%. When control terminal is open, speed is the same as at 0% duty cycle.

The models listed below **have no sensors.**

Model no.	Rated voltage [V]	Operating voltage range [V]	Frequency [Hz]	Rated current [A]	Rated input [W]	Rated speed [min <sup>-1</sup> ]	Max. airflow [m <sup>3</sup> /min] [CFM]	Max. static pressure [Pa] [inchH <sub>2</sub> O]	SPL [dB(A)]	Operating temperature [°C]	Expected life [h]
9ADW1601H5002	100 to 240	90 to 264	50/60	0.46	22	4150	8.2 290	167 0.66	58	-20 to +70	40000/60°C (70000/40°C)

#### Terminal model

The models listed below **have pulse sensors with PWM control function.**

Model no.	Rated voltage [V]	Operating voltage range [V]	Frequency [Hz]	PWM duty cycle* [%]	Rated current [A]	Rated input [W]	Rated speed [min <sup>-1</sup> ]	Max. airflow [m <sup>3</sup> /min] [CFM]	Max. static pressure [Pa] [inchH <sub>2</sub> O]	SPL [dB(A)]	Operating temperature [°C]	Expected life [h]
9ADW1601P5HT03	100 to 240	90 to 264	50/60	100	0.46	22	4150	8.2 290	167 0.66	58	-20 to +70	40000/60°C (70000/40°C)
				0	0.10	4.0	1500	3.07 108	44 0.17	31		

\* PWM frequency is 25 kHz. Models without ratings for 0% PWM duty cycle have zero speed at 0%. When control terminal is open, speed is the same as at 0% duty cycle.

The models listed below **have no sensors.**

Model no.	Rated voltage [V]	Operating voltage range [V]	Frequency [Hz]	Rated current [A]	Rated input [W]	Rated speed [min <sup>-1</sup> ]	Max. airflow [m <sup>3</sup> /min] [CFM]	Max. static pressure [Pa] [inchH <sub>2</sub> O]	SPL [dB(A)]	Operating temperature [°C]	Expected life [h]
9ADW1601H5T02	100 to 240	90 to 264	50/60	0.46	22	4150	8.2 290	167 0.66	58	-20 to +70	40000/60°C (70000/40°C)

Models with the following sensor specifications are also available as options: **Lock sensor** **Low-speed sensor**

### Common Specifications

- Material ..... Frame: Aluminum (Black coating), Impeller: Plastic (Flammability: UL 94V-0)
- Expected life ..... Refer to specifications  
(L10 life: 90% survival rate for continuous operation in indoor free air at 60°C, rated voltage)  
Expected life at 40°C is for reference only.
- Motor protection function ..... Locked rotor burnout protection
- Dielectric strength ..... 50/60 Hz, 1500 VAC, for 1 minute  
(Lead wire model: between lead wire conductors and frame, Terminal model: between terminal and frame)
- Insulation resistance ..... 10 MΩ min. at 500 VDC  
(Lead wire model: between lead wire conductors and frame, Terminal model: between terminal and frame)
- Sound pressure level (SPL) ..... A-weighted sound pressure level (SPL) at 1 m away from the air inlet.
- Operating temperature ..... Refer to specifications (Non-condensing)
- Storage temperature ..... -30 to +70°C (Non-condensing)
- Lead wire ..... (AC power input) L: Orange N: Gray  
(Sensor) Yellow (Control) Brown (GND) Black
- Mass ..... 940 g
- Ingress protection ..... IP56 (Excluding the connectors of terminal models)

## Airflow - Static Pressure Characteristics

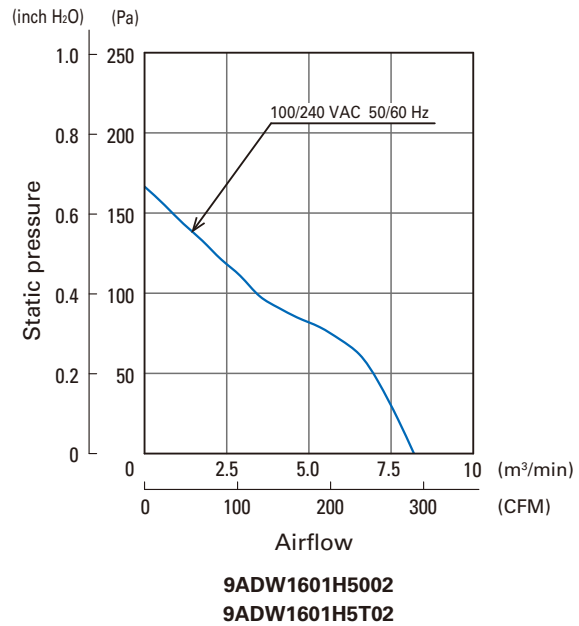
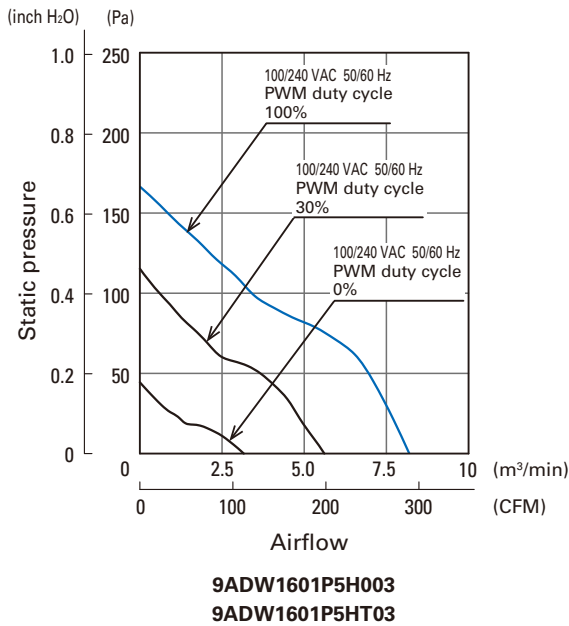

## PWM Duty - Speed Characteristics Example

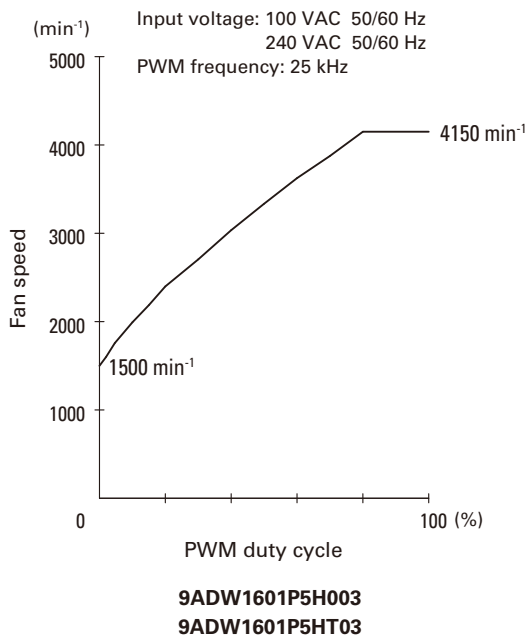

### PWM Input Signal Example

Input signal waveform

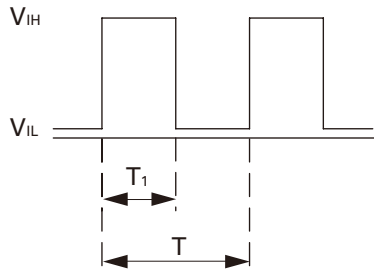

$V_{IH} = 4.75 \text{ to } 5.25 \text{ V}$     $V_{IL} = 0 \text{ to } 0.4 \text{ V}$   
 PWM duty cycle (%) =  $\frac{T_1}{T} \times 100$    PWM frequency 25 (kHz) =  $\frac{1}{T}$   
 Current source ( $I_{source}$ ) = 1.0 mA max. (when control voltage is 0 V)  
 Current sink ( $I_{sink}$ ) = 10 mA max. (when control voltage is 5.25 V)

When the PWM control terminal is open, the fan speed is the same as the speed at 0% PWM duty cycle. A TTL input can be used for the PWM input signal.

### Example of Connection Schematic

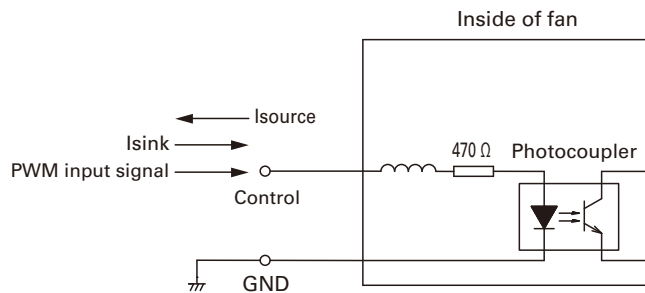

### Specifications for Pulse Sensors

Output circuit: Open collector

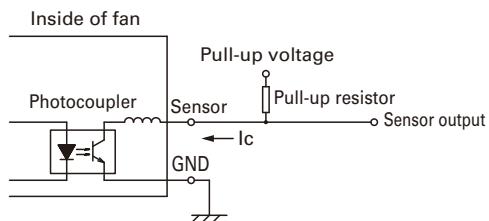

$V_{CE} = +60 \text{ V max.}$   
 $I_c = 10 \text{ mA max.}$  [ $V_{OL} = V_{CE(SAT)} = 1.2 \text{ V max.}$ ]

Output waveform (Need pull-up resistor)

In case of steady running

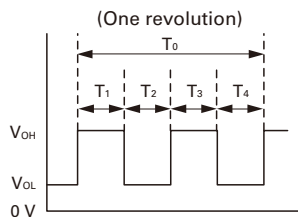

$T_{1 \text{ to } 4} \doteq (1/4) T_0$   
 $T_{1 \text{ to } 4} \doteq (1/4) T_0 = 60/4N \text{ (s)}$   
 $N = \text{Fan speed (min}^{-1}\text{)}$

## Dimensions (unit: mm) (With pulse sensor with PWM control function)

### Lead wire model

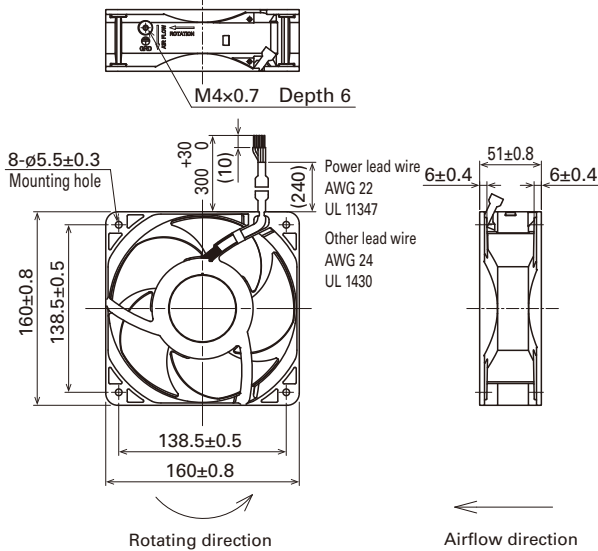

### Terminal model

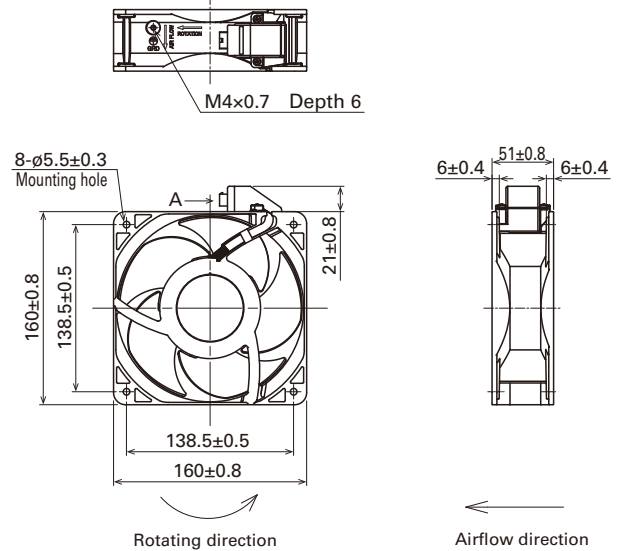

### A Connector contact

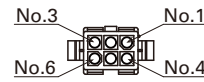

### Pin arrangement

Connector (Model no.: TE Connectivity: 1-172160-9)

Pin No.	Function	Input
1	L	AC
2	No connection	-
3	N	AC
4	PWM	DC
5	GND	DC
6	Sensor	DC

## Reference Dimensions of Mounting Holes and Vent Opening (unit: mm)

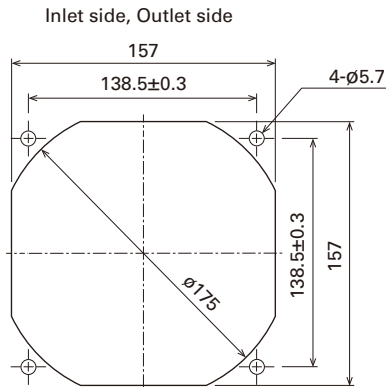

## Options

### Finger guards

Model no.: 109-619E, 109-619H, 109-620

### Terminal model wiring harness

Model no.: 489-1647

## Notice

- Please read the "Safety Precautions" on our website before using the product.
- The products shown in this catalog are subject to Japanese Export Control Law. Diversion contrary to the law of exporting country is prohibited.
- For protecting fan bearings against electrolytic corrosion near strong electromagnetic noise sources, we provide effective countermeasures such as Electrolytic Corrosion Proof Fans and EMC guards. Contact us for details.

**SANYO DENKI CO., LTD.** 3-33-1 Minami-Otsuka, Toshima-ku, Tokyo 170-8451, Japan TEL: +81 3 5927 1020

<https://www.sanyodenki.com/>

The names of companies and/or their products specified in this document are the trade names, and/or trademarks and/or registered trademarks of such respective companies. San Ace, SANUPS, and SANMOTION are trademarks of SANYO DENKI CO., LTD.

Specifications are subject to change without notice.

CATALOG No. C1131B001 '22.8