

LEAD STYLES

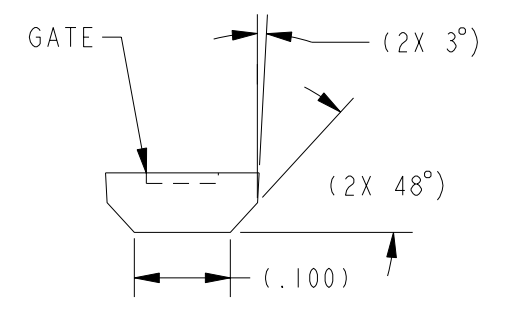

ALL EXCEPT "L" LEAD STYLES

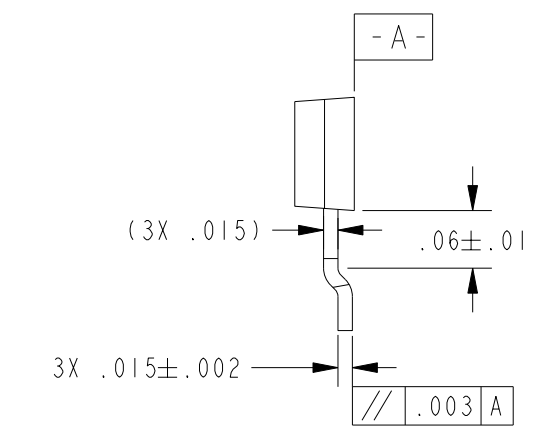
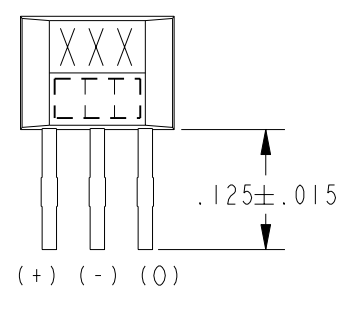
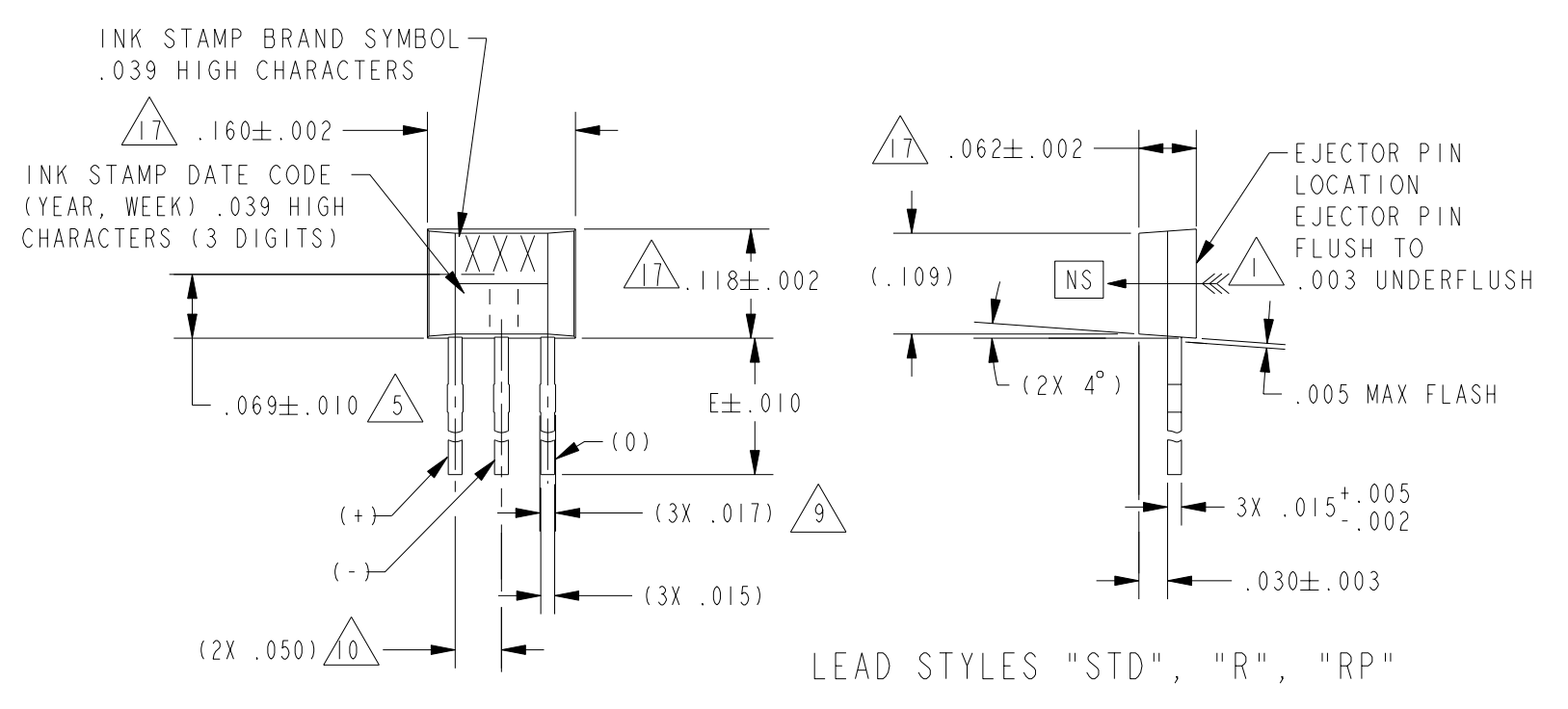

LEAD STYLES "S" & "SP"

NOTES

- 1 THE MAGNETIC FLUX USED TO OPERATE THE SWITCH MUST BE IN THE DIRECTION AND LOCATION SHOWN (THIS ASSUMES THE CONVENTION THAT THE DIRECTION OF THE EXTERNAL FLUX OF A MAGNET IS FROM THE NORTH TO THE SOUTH POLE OF THE MAGNET)
- 2 THE MAGNETIC FIELD STRENGTH (GAUSS) REQUIRED TO CAUSE THE SWITCH TO CHANGE STATE (OPERATE AND RELEASE) WILL BE AS TABULATED. TO TEST THE SWITCH AGAINST THE SPECIFIED LIMITS, THE SWITCH MUST BE PLACED IN A UNIFORM MAGNETIC FIELD
- 3 ABSOLUTE MAXIMUM RATINGS ARE THE EXTREME LIMITS THE DEVICE WILL MOMENTARILY WITHSTAND WITHOUT DAMAGE TO THE DEVICE. ELECTRICAL AND MAGNETIC CHARACTERISTICS ARE NOT GUARANTEED IF THE RATED VOLTAGE AND/OR CURRENTS ARE EXCEEDED NOR WILL THE DEVICE NECESSARILY OPERATE AT ABSOLUTE MAXIMUM RATINGS
- 4 AMMOPACK STYLE "T2" & "T3". 24 SWITCHES BETWEEN FOLDS, SKIP 1 SPACE AT FOLD. MAY BE REFERRED TO AS "FAN FOLD"
- 5 HALL ELEMENT LOCATION WITH INTEGRATED CIRCUIT TOLERANCE
- 6 LEADS MUST BE ADEQUATELY SUPPORTED DURING ANY FORMING/SHEERING OPERATION TO ASSURE THAT THE LEADS ARE NOT STRESSED WITHIN THE PLASTIC
- 7 PCB WAVE SOLDERING GUIDELINES ARE AS FOLLOWS:  
250°C TO 260°C SOLDERING TEMPERATURE 3 SECONDS MAX  
SOLDERING TIME
- 8 28 VDC MAX EXTERNALLY APPLIED OUTPUT VOLTAGE IN OFF CONDITION ONLY, -0.5 VDC LIMIT MAY BE APPLIED WITH SWITCH IN ON OR OFF CONDITION
- 9 BURRS ARE ALLOWED ONLY IF FULL LENGTH OF LEADS WILL PASS THROUGH Ø.023 HOLE. LEAD REFERENCE DIMENSIONS DO NOT INCLUDE SOLDER THICKNESS
- 10 DIMENSION REFERS TO THE LOCATION OF LEAD CENTERLINES AS THEY EXIT THE PLASTIC PACKAGE
- 11 TYPICAL DIMENSIONS NOT SHOWN IN LEAD STYLE "S"
- 12 SOME COMBINATIONS OF BASIC LISTING AND PACKING OPTIONS ARE NOT AVAILABLE
- 13 TAPE AND AMMOPACK PER EIA-468-A-1990
- 14 TAPE AND REEL PER EIA-481-A-1986
- 15 LEAD STRAIGHTNESS MAY BE DETERIORATED ON SOME UNITS BY BULK PACKAGING. APPLICATIONS HAVING A CRITICAL LEAD STRAIGHTNESS REQUIREMENT SHOULD USE A TAPE PACKAGING OPTION
- 16 SOURCE VOLTAGE IS 12VDC UNLESS OTHERWISE SPECIFIED
- 17 MOLDED PART DIMENSIONS DO NOT INCLUDE FLASH. FLASH IS LIMITED TO .005 MAX
- 18 THESE HALL EFFECT SENSORS MAY HAVE AN INITIAL OUTPUT IN EITHER THE ON OR OFF STATE IF POWERED UP WITH AN APPLIED MAGNETIC FIELD IN THE DIFFERENTIAL ZONE (APPLIED MAGNETIC FIELD > Brp AND < Bop). MICRO SWITCH RECOMMENDS THAT THE APPLICATION CIRCUIT DESIGNER ALLOW 10 MICROSECONDS AFTER SUPPLY VOLTAGE HAS REACHED 5 VOLTS FOR THE OUTPUT VOLTAGE TO STABILIZE

SS40 SERIES CHART 1  
 PAGE 1 OF 4  
 RELEASE NO. CO-75147B  
 REPLACES  
 DRAWING NUMBER  
 ISSUE 16  
 REVISIONS  
 A 205183  
 GLH 26MAR02  
 B 206240  
 TSM 28AUG02  
 C 206425  
 JLB 11SEP02  
 CHECK  
 P.T.C./CAD 30  
 DRAWN  
 GLH 26MAR02  
 CHECK  
 SAV 26MAR02  
 CHECK  
 26MAR02  
 P.T.C./CAD 30  
 DRAWN  
 GLH 26MAR02  
 CHECK  
 SAV 26MAR02  
 CHECK  
 26MAR02

THIS DRAWING COVERS A PROPRIETARY ITEM AND IS THE PROPERTY OF MICRO SWITCH, A DIVISION OF HONEYWELL. THIS DRAWING IS NOT TO BE COPIED OR USED WITHOUT THE APPROVAL OF MICRO SWITCH.

**MICRO SWITCH**  
a Honeywell Division

**SOLID STATE SENSOR**

CATALOG LISTING  
**SS40 SERIES CHART 1**

FED. MFG. CODE 91929

THIRD ANGLE PROJECTION		
SCALE 5:1		
DO NOT SCALE PRINT		
UNLESS OTHERWISE SPECIFIED TOLERANCES ARE		
ONE PLACE	(.0)	±.030
TWO PLACES	(.00)	±.015
THREE PLACES	(.000)	±.005
ANGLES		±
WEIGHT		

CATALOG LISTING  
**SS40 SERIES CHART 1**  
PAGE 2 OF 4  
RELEASE NO. CO-75147B  
REPLACES -  
CHECK  
REVISIONS  
A C093816 KED 18JAN99  
B C094110 TSM 18AUG99  
C 205183 GLH 26MAR02  
D 206240 TSM 28AUG02  
E 206425 JLH 11SEP02  
CHECK  
18JAN99  
JAF  
CHECK  
18JAN99  
DRAWN  
PTC/CAD 3D  
KED 18JAN99

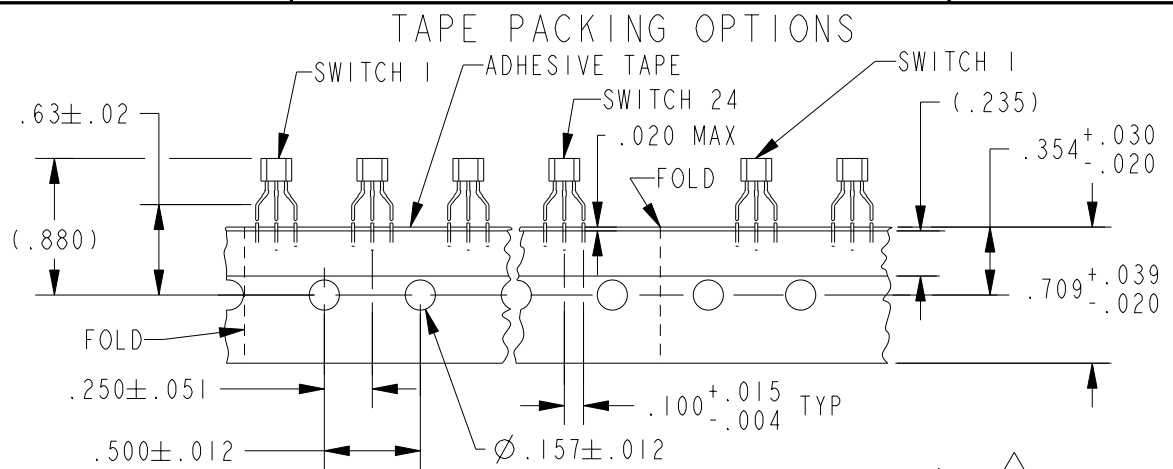

TAPE STYLE "T2"  $\triangle 4$   $\triangle 13$

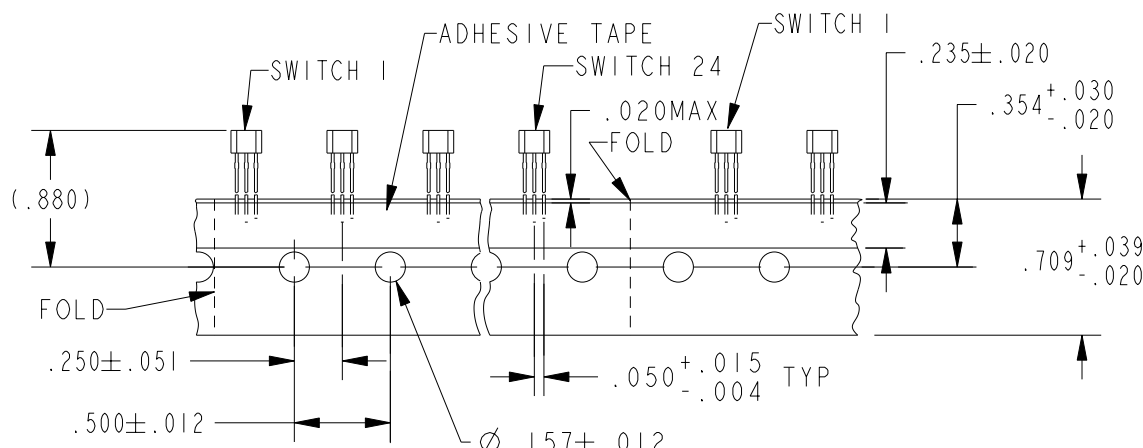

TAPE STYLE "T3"  $\triangle 4$   $\triangle 13$

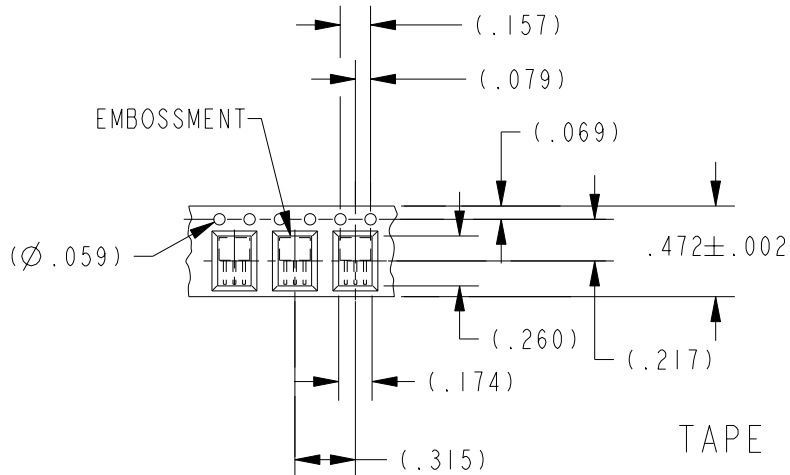
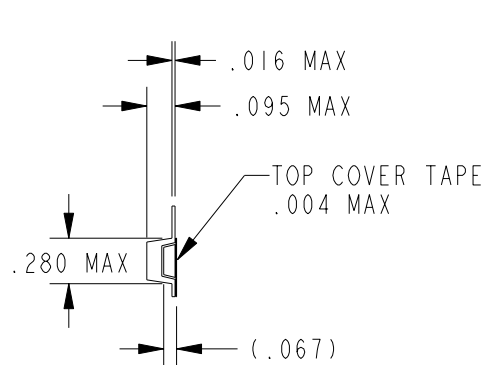

TAPE STYLE "SP" & "RP"  $\triangle 14$

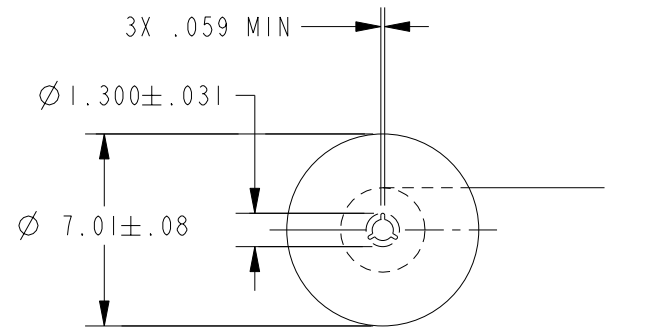

DIRECTION OF FEED FROM REEL

PREFIX SUFFIX  
BASIC CATALOG LISTING: PACKAGE STYLE, MAGNETIC TYPE, ELECTRICAL/MAGNETIC SPECS  
LEAD & PACKAGING OPTIONS: BULK, TAPE & REEL, POCKET TAPE & REEL

CHARACTERS IN THESE POSITIONS OF THE LISTING ARE BRANDED ON THE PRODUCT

SS4=PACKAGE STYLE  
MAGNETIC TYPE  
1=BIPOLAR  
4=UNIPOLAR  
6=LATCH  
9=LINEAR  
ELECTRICAL/MAGNETIC OPTIONS  
(A-K, & U-Z) A=STANDARD  
B-K & U-Z=SPECIALS  
SPECIAL FEATURE (BLANK, 1-9)  
BLANK=STANDARD  
1-9=SPECIALS

DESCRIPTION	NOMINAL LEAD SPACING	NOMINAL "E" DIM LENGTH	PARTS PER CONTAINER
STANDARD, BULK PACK $\triangle 15$	.050	.590	1000/BAG
-T 2 TAPE, AMMOPACK	.100	.590	5000/BOX
-T 3 TAPE, AMMOPACK	.050	.590	5000/BOX
-S SURF MOUNT, BULK PACK	.050	.125	1000/BAG
-S P SURF MOUNT, POCKET TAPE	.050	.125	1000/REEL
-R REDUCED LENGTH, BULK PACK	.050	.130	1000/BAG
-R P REDUCED LENGTH, POCKET TAPE	.050	.130	1000/REEL
-L LONG LEADS, BULK PACK	.050	.735	1000/BAG

THIRD ANGLE PROJECTION	
SCALE 5 : 1	
DO NOT SCALE PRINT	
UNLESS OTHERWISE SPECIFIED TOLERANCES ARE	
ONE PLACE (.0)	±.030
TWO PLACE (.00)	±.015
THREE PLACE (.000)	±.005
ANGLES	±
WEIGHT	

CATALOG LISTING  
**SS40 SERIES CHART 1**  
 PAGE 3 OF 4  
 RELEASE NO. CO-75147B  
 REPLACES  
 CHECK  
 REVISIONS  
 A C093816 KED 18 JAN 99  
 B C094110 TSM 18 AUG 99  
 C 205183 GLH 26 MAR 02  
 D 206240 TSM 28 AUG 02  
 E 206425 JLH 11 SEP 02  
 CHECK  
 18 JAN 99  
 JAF  
 CHECK  
 18 JAN 99  
 DRAWN  
 PTC/CAD 3D  
 KED

TABLE 1 - MAGNETIC AND ELECTRICAL SPECIFICATIONS



	-40°C	0°C	25°C	85°C	125°C	150°C
MIN OPERATE GAUSS						
SS4I	NS	NS	NS	NS	NS	NS
SS4ID	NS	NS	NS	NS	NS	NS
MAX OPERATE GAUSS						
SS4I	200	150	150	150	200	250
SS4ID	340	340	340	340	NS	NS
MIN RELEASE GAUSS						
SS4I	-160	-160	-140	-150	-200	-250
SS4ID	-340	-340	-340	-340	NS	NS
MAX RELEASE GAUSS						
SS4I	NS	NS	NS	NS	NS	NS
SS4ID	NS	NS	NS	NS	NS	NS
MIN DIFF GAUSS						
SS4I	40	50	50	50	60	60
SS4ID	40	40	40	40	NS	NS

TABLE 2

	SS4I	SS4ID
MAGNETIC TYPE	BIPOLAR	BIPOLAR
BRAND SYMBOL	S4I	S4I
PACKING	BAG	BAG
SPECIFIED VOLTAGE RANGE	4.5 - 24	4.5 - 24
MAX I <sub>off</sub> milliamp	10.0	10.0
MAX I <sub>on</sub> milliamp	11.3	11.3
RATED SINK CURRENT M <sub>a</sub>	20	20
MAX V <sub>sat</sub> VOLTS 25°C /16\	0.4	0.4
MAX LEAKAGE AT 24V, μA	10	10
RISE TIME AT 25°C 10% TO 90% μS	1.5	1.5
FALL TIME AT 25°C 90% TO 10% μS	1.5	1.5
STORAGE TEMP °C	-40 TO +150	-40 TO +150
OPERATING TEMP °C	-40 TO +150	-40 TO +85

ABSOLUTE LIMITS	SS4I	SS4ID
SUPPLY VOLTAGE	-28 TO +28	-24 TO +28
APPLIED OUTPUT VOLTAGE /8\	-0.5 TO +28	-0.5 TO +28
OUTPUT CURRENT mA	20	20
MAGNETIC FLUX GAUSS	NO LIMIT	NO LIMIT

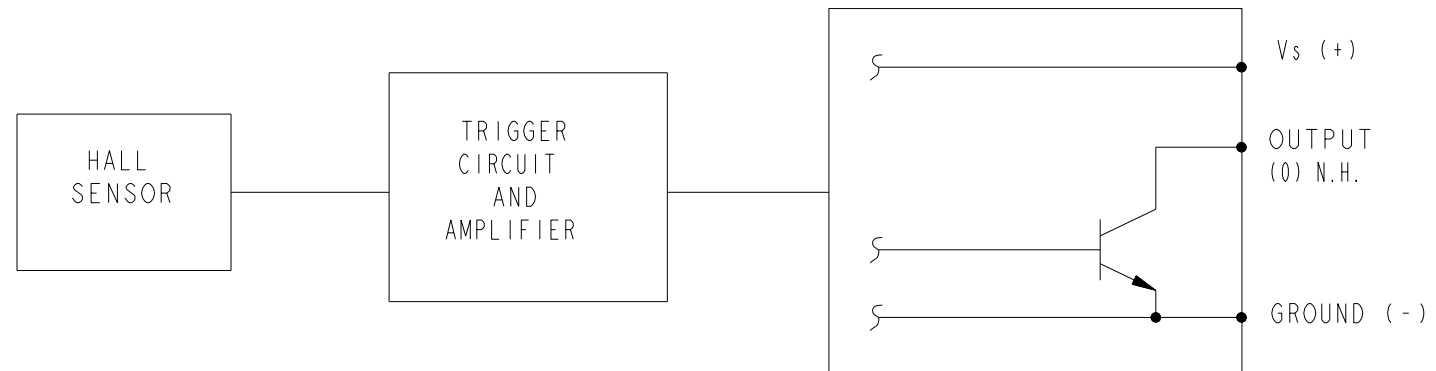

THIRD ANGLE PROJECTION

SCALE NONE

DO NOT SCALE PRINT

UNLESS OTHERWISE SPECIFIED TOLERANCES ARE

ONE PLACE	(.0)	±.030
TWO PLACE	(.00)	±.015
THREE PLACE	(.000)	±.005
ANGLES		±

WEIGHT

CATALOG LISTING **SS40 SERIES CHART 1**  
PAGE 4 OF 4

REVISIONS

PTC/CAD 3D  
DRAWN  
KED 18JAN99  
CHECK  
JAF  
CHECK  
18JAN99

ISSUE **16**  
CHECK  
REPLACES  
RELEASE NO. CO-75147B

SS41 DIGITAL BIPOLAR

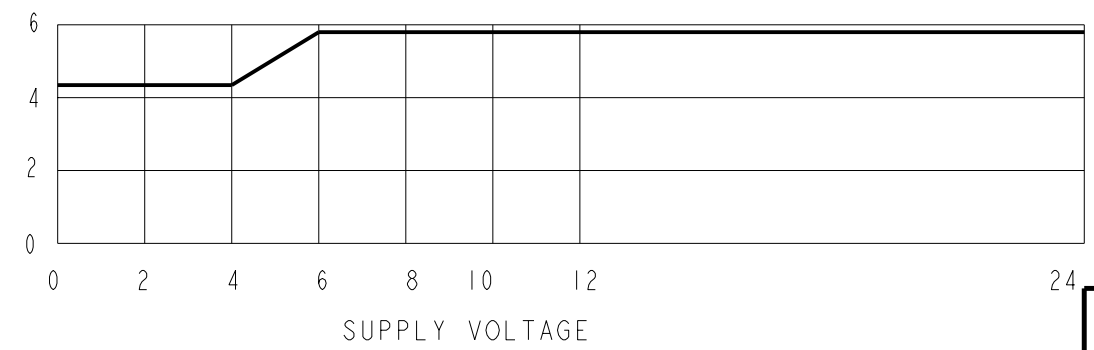
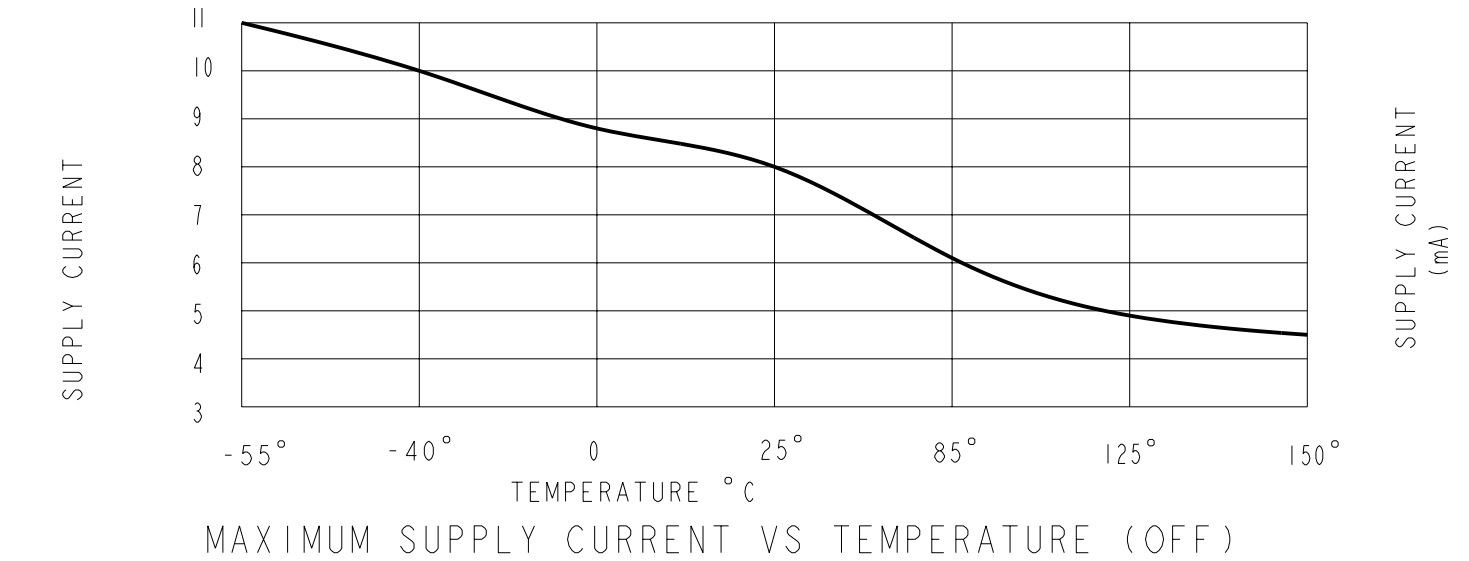
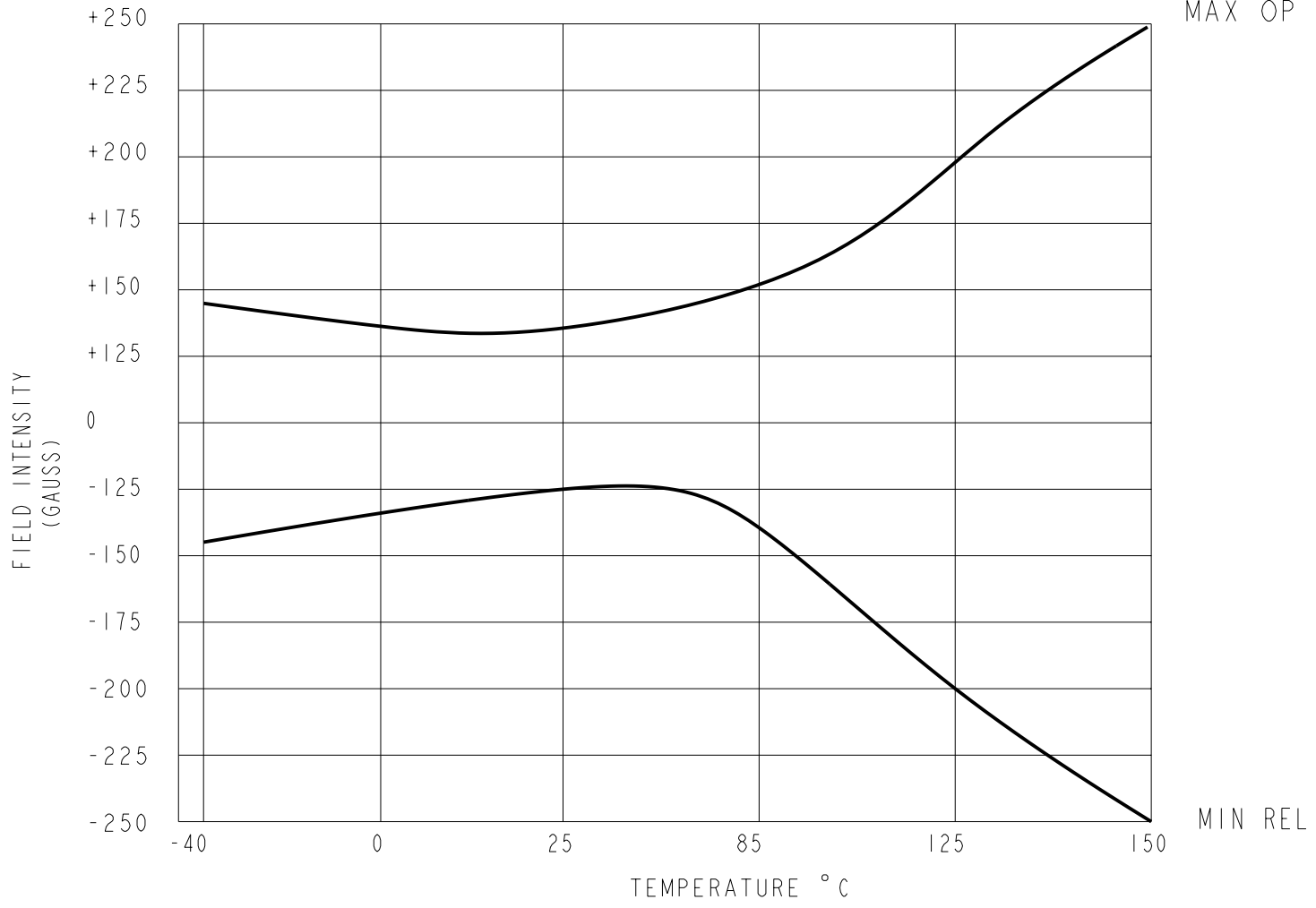

TYPICAL SUPPLY CURRENT (DEVICE OFF) AT 25°C

THIRD ANGLE PROJECTION

SCALE NONE

DO NOT SCALE PRINT

UNLESS OTHERWISE SPECIFIED TOLERANCES ARE

ONE PLACE	(.0)	±.030
TWO PLACE	(.00)	±.015
THREE PLACE	(.000)	±.005
ANGLES		±

WEIGHT