

## LSM6DSL adapter board for a standard DIL24 socket

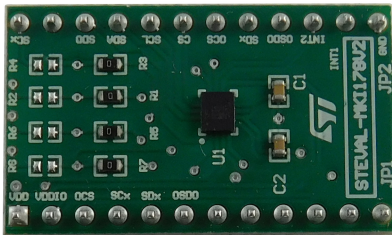

### Features

- Complete **LSM6DSL** pinout for a standard DIL24 socket
- Default compatibility with STEVAL-MKI109V3 motherboard
- Also compatible with the STEVAL-MKI109V2 motherboard by changing resistor settings (R2, R4, R6 and R8)
- RoHS compliant

### Description

The **STEVAL-MKI178V2** adapter board is designed to facilitate the evaluation of MEMS devices in the **LSM6DSL** product family. The board offers an effective solution for fast system prototyping and device evaluation directly inside your own application.

The **STEVAL-MKI178V2** can be plugged into a standard DIL 24 socket. The adapter provides the complete LSM6DSL pin-out and comes ready-to-use with the required decoupling capacitors on the VDD power supply line.

This adapter is supported by the **STEVAL-MKI109V2** and **STEVAL-MKI109V3** motherboards, which include a high performance 32-bit microcontroller functioning as a bridge between the sensor and a PC, on which it is possible to use the downloadable graphical user interface (Unico GUI), or dedicated software routines for customized applications.

Summary table	
STEVAL-MKI178V2 adapter board	<a href="#">STEVAL-MKI178V2</a>
STEVAL-MKI109V2 motherboard	<a href="#">STEVAL-MKI109V2</a>
STEVAL-MKI109V3 motherboard	<a href="#">STEVAL-MKI109V3</a>
LSM6DSL system-in-package featuring a 3D digital accelerometer and a 3D digital gyroscope	<a href="#">LSM6DSL</a>

# 1 Schematic diagram

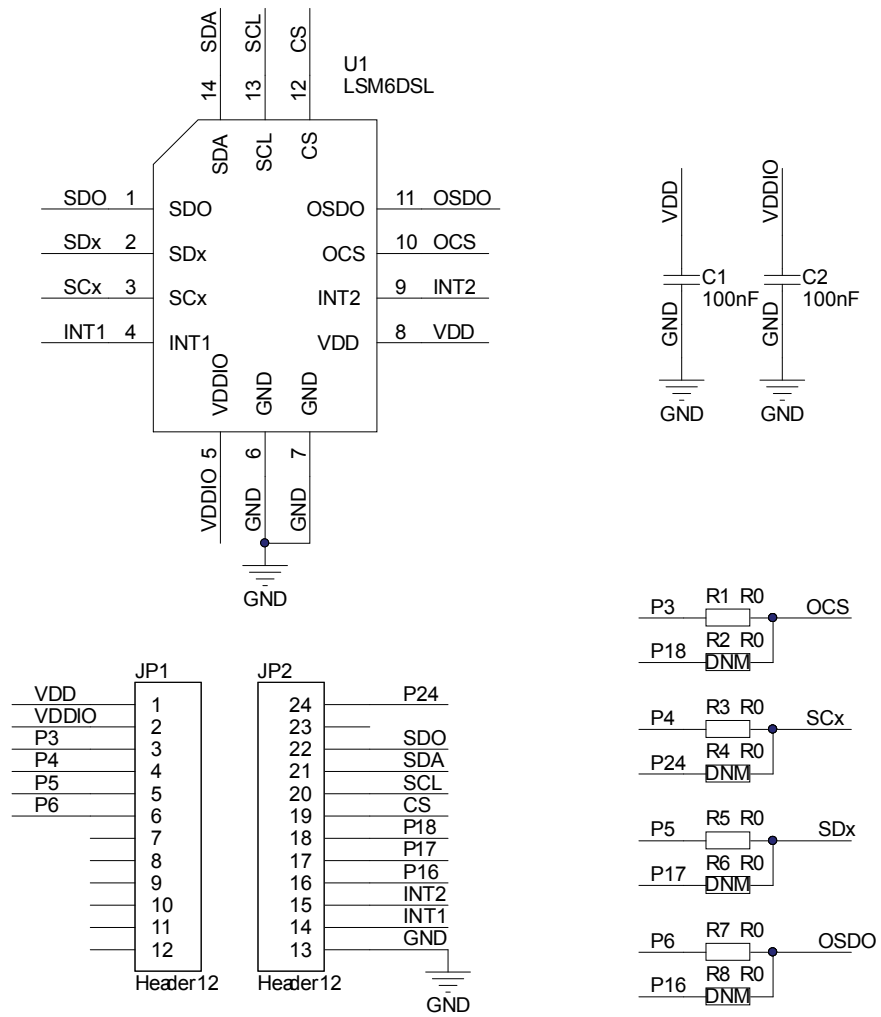
**Figure 1. STEVAL-MKI178V2 circuit schematic**

## Revision history

**Table 1. Document revision history**

Date	Version	Changes
12-Feb-2018	1	Initial release.

**IMPORTANT NOTICE – PLEASE READ CAREFULLY**

STMicroelectronics NV and its subsidiaries (“ST”) reserve the right to make changes, corrections, enhancements, modifications, and improvements to ST products and/or to this document at any time without notice. Purchasers should obtain the latest relevant information on ST products before placing orders. ST products are sold pursuant to ST’s terms and conditions of sale in place at the time of order acknowledgement.

Purchasers are solely responsible for the choice, selection, and use of ST products and ST assumes no liability for application assistance or the design of Purchasers’ products.

No license, express or implied, to any intellectual property right is granted by ST herein.

Resale of ST products with provisions different from the information set forth herein shall void any warranty granted by ST for such product.

ST and the ST logo are trademarks of ST. All other product or service names are the property of their respective owners.

Information in this document supersedes and replaces information previously supplied in any prior versions of this document.

© 2018 STMicroelectronics – All rights reserved