

Normzahnriemenräder, Zoll-Teilung ISO 5294

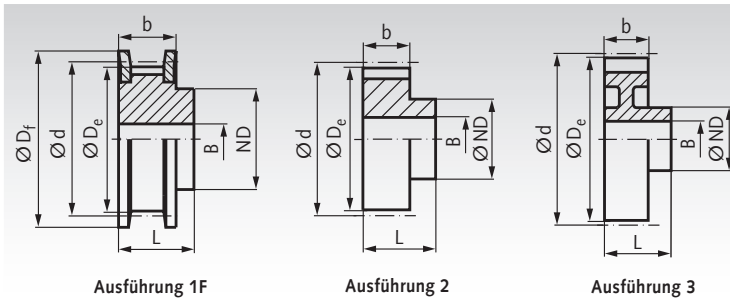

Werkstoff: Aluminium ähnlich EN AW2017A.

Bordscheiben Stahl verzinkt. Bohrungen vorgebohrt*.

Bestellangaben: z.B.: Art.-Nr. 180 110 00, Zahnriemenräder, Tlg. XL = 1/5", 10 Zähne, Zahnriemenbreite 025, 2 Bordscheiben

XL 025: Teilung 1/5" = 5,08 mm für Zahnriemenbreite 0,25" = 6,35 mm

Artikel-Nr.	Zähnezahl	Ausführung	De mm	Df mm	d mm	ND mm	b mm	L mm	B mm	Gewicht g
180 110 00	10	1F	15,66	23	16,17	10	8,9	14	-	10
180 111 00	11	1F	17,28	23	17,79	10	8,9	14	-	16
180 112 00	12	1F	18,90	25	19,40	10	8,9	14	-	20
180 113 00	13	1F	20,51	25	21,02	10	8,9	14	-	25
180 114 00	14	1F	22,13	28	22,64	16	8,9	14	-	29
180 115 00	15	1F	23,75	28	24,26	16	8,9	14	-	35
180 116 00	16	1F	25,36	32	25,87	16	8,9	14	-	41
180 117 00	17	1F	26,98	32	27,49	20	8,9	14	-	50
180 118 00	18	1F	28,60	36	29,11	20	8,9	14	-	59
180 119 00	19	1F	30,22	36	30,72	20	8,9	16	-	61
180 120 00	20	1F	31,83	38	32,34	25	8,9	16	-	78
180 121 00	21	1F	33,45	38	33,96	25	8,9	16	-	84
180 122 00	22	1F	35,07	42	35,57	25	8,9	16	-	90
180 124 00	24	1F	38,30	44	38,81	30	8,9	16	-	113
180 126 00	26	1F	41,53	48	42,04	30	8,9	16	6	126
180 127 00	27	1F	43,15	48	43,66	34	8,9	16	6	139
180 128 00	28	1F	44,77	51	45,28	34	8,9	16	6	152
180 130 00	30	1F	48,00	54	48,51	38	8,9	16	6	177
180 132 00	32	1F	51,24	57	51,74	38	8,9	18	6	215
180 134 00	34	1F	54,47	60	54,98	38	8,9	18	6	237
180 135 00	35	1F	56,09	63	56,60	38	8,9	18	6	245
180 136 00	36	2	57,70	-	58,21	45	8,9	18	6	99
180 138 00	38	2	60,94	-	61,45	45	8,9	18	6	110
180 140 00	40	2	64,17	-	64,68	45	8,9	18	6	116
180 142 00	42	2	67,41	-	67,91	45	8,9	18	6	125
180 144 00	44	2	70,64	-	71,15	45	8,9	18	6	135
180 148 00	48	3	77,11	-	77,62	45	8,9	18	8	126
180 160 00	60	3	96,51	-	97,02	45	8,9	18	8	149
180 172 00	72	3	115,92	-	116,42	45	8,9	18	8	192

* Bis Zz = 24 nur Zentrierbohrung.

XL 037: Teilung 1/5" = 5,08 mm für Zahnriemenbreite 0,37" = 9,53 mm

Artikel-Nr.	Zähnezahl	Ausführung	De mm	Df mm	d mm	ND mm	b mm	L mm	B mm	Gewicht g
180 310 00	10	1F	15,66	23	16,17	10	14,3	20	-	21
180 311 00	11	1F	17,28	23	17,79	10	14,3	20	-	23
180 312 00	12	1F	18,90	25	19,40	10	14,3	20	-	29
180 313 00	13	1F	20,51	25	21,02	10	14,3	20	-	36
180 314 00	14	1F	22,13	28	22,64	16	14,3	20	-	42
180 315 00	15	1F	23,75	28	24,26	16	14,3	20	-	50
180 316 00	16	1F	25,36	32	25,87	16	14,3	20	-	58
180 317 00	17	1F	26,98	32	27,49	20	14,3	20	-	71
180 318 00	18	1F	28,60	36	29,11	20	14,3	20	-	84
180 319 00	19	1F	30,22	36	30,72	20	14,3	22	-	87
180 320 00	20	1F	31,83	38	32,34	25	14,3	22	-	111
180 321 00	21	1F	33,45	38	33,96	25	14,3	22	-	111
180 322 00	22	1F	35,07	42	35,57	25	14,3	22	-	129
180 324 00	24	1F	38,30	44	38,81	30	14,3	22	-	161
180 326 00	26	1F	41,53	48	42,04	30	14,3	22	8	180
180 327 00	27	1F	43,15	48	43,66	34	14,3	22	8	199
180 328 00	28	1F	44,77	51	45,28	34	14,3	22	8	217
180 330 00	30	1F	48,00	54	48,51	38	14,3	22	8	253
180 332 00	32	1F	51,24	57	51,74	38	14,3	25	8	307
180 334 00	34	1F	54,47	60	54,98	38	14,3	25	8	339
180 335 00	35	1F	56,09	63	56,60	38	14,3	25	8	350
180 336 00	36	2	57,70	-	58,21	45	14,3	25	8	142
180 338 00	38	2	60,94	-	61,45	45	14,3	25	8	157
180 340 00	40	2	64,17	-	64,68	45	14,3	25	8	165
180 342 00	42	2	67,41	-	67,91	45	14,3	25	8	178
180 344 00	44	2	70,64	-	71,15	45	14,3	25	8	193
180 348 00	48	3	77,11	-	77,62	45	14,3	25	10	180
180 360 00	60	3	96,51	-	97,02	45	14,3	25	10	213
180 372 00	72	3	115,92	-	116,42	45	14,3	25	10	274

* Bis Zz = 24 nur Zentrierbohrung.

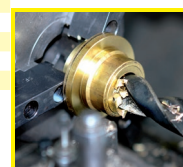

Fertigbearbeitung im
24-Stunden-Service möglich.
Sonderanfertigungen und
Zeichnungsteile auf Anfrage.